



Badger Meter

**Electronic Preset Meter 2 Advanced Series Special
Fluids Plus**

Model EPM2-ADV-SF Plus



**IMPORTANT:
This manual contains important information.
READ AND KEEP FOR REFERENCE.**

Disclaimer

The user/purchaser is expected to read and understand the information provided in this manual, follow any listed Safety Precautions and Instructions and keep this manual with the equipment for future reference.

The information in this manual has been carefully checked and is believed to be entirely reliable and consistent with the product described. However, no responsibility is assumed for inaccuracies, nor does Badger Meter Inc. assume any liability arising out of the application and use of the equipment described.

Should the equipment be used in a manner not specified by Badger Meter, Inc., the protection provided by the equipment may be impaired and the warranty voided.

Questions or Service Assistance

If you have questions regarding the product or this document contact:

Badger Meter, Inc.
P.O. Box 245036
Milwaukee, WI 53224-9536

Telephone: (414) 355-0400
(877) 243-1010
Fax: (414) 355-7499
(866) 613-9305

On the Web: www.badgermeter.com
or call your local Badger Meter representative.

Product Identification Information

Record the product identification numbers from the nameplate here.

Model Number _____

Serial Number _____

Tag Number _____ (if applicable)

Table of Contents

| | |
|--|---------------------|
| DISCLAIMER | Back of front cover |
| QUESTIONS or SERVICE ASSISTANCE | Back of front cover |
| PRODUCT IDENTIFICATION INFORMATION | Back of front cover |
| Table of Contents..... | i |
| ⚠ WARNING Explosions and Fire Hazards | ii |
| ⚠ WARNING Meter Hazards | ii |
| ⚠ WARNING Designed for Special Fluids..... | ii |
| METER BUTTONS | 1 |
| LCD DISPLAY..... | 1 |
| METER INSTALLATION..... | 2 |
| Relieve System Pressure..... | 2 |
| Grounding | 2 |
| Flushing Procedure | 2 |
| Apply Meter to Hose..... | 3 |
| Apply Nozzle to Meter | 3 |
| METER OPERATION | 4 |
| Manual Mode | 4 |
| Auto Batch Mode | 4 |
| Count Up/Count Down Modes | 6 |
| OPERATING MODE FUNCTIONS | 7 |
| Re-settable/Accumulated Totals .. | 7 |
| Emergency Override | 7 |
| History | 7 |
| Flow Rate | 8 |
| Error Codes..... | 8 |
| SERVICE | 9 |
| Low Battery | 9 |
| Changing the Battery | 9 |
| CHANGE FACTORY SETTINGS | 10 |
| Verify Firmware | 10 |
| Programming..... | 10 |
| Change Unit of Measure | 10 |
| Change Scale Factor | 11 |
| Save Changes..... | 11 |
| Verify Changes..... | 11 |
| CALCULATE SCALE FACTOR | 12 |
| Absolute Scale Factor | 12 |
| Chart of Scale Factors | 13 |
| Sample Fluids, Viscosities and Scale Factors | 13 |
| Specifications..... | 14 |
| Parts Drawings..... | 15 to 17 |
| Troubleshooting | 18 |

⚠ WARNING

EXPLOSION and FIRE HAZARDS

Improper grounding, poor ventilation, open flames or sparks can cause a hazardous condition and result in an explosion or fire and cause serious injury.

- Be sure the fluid system is properly grounded. See your pump instruction manual for details.
- If there is static sparking or if you feel an electric shock while using the meter, stop dispensing immediately. Identify and correct the problem before continuing.
- Provide fresh air ventilation. This will avoid the buildup of fumes from the fluid being dispensed.
- Do not smoke while dispensing flammable fluids.
- Keep the dispensing area free of debris including solvents, rags and spilled gasoline.

⚠ WARNING

METER HAZARDS

Equipment misuse can cause the meter to rupture or malfunction and cause serious injury.

- This equipment is for professional use only.
- Read all instructions, tags and labels before operating the equipment.
- Use the equipment only for its intended purpose.
- Do **NOT** modify or alter the equipment.
- Do **NOT** leave equipment unattended while dispensing.
- Check equipment daily. Repair or replace worn or damaged parts immediately.
- Do **NOT** exceed the maximum working pressure level of the lowest rated system component.
- Use only extensions and nozzles that are designed for use with this equipment.
- Use only fluids and solvents that are compatible with the equipment. Read all fluid and solvent manufacturer's warnings.
- Tighten all fluid connections before operating this equipment.
- Do **NOT** stop or deflect leaks with hands, body, gloves or rags.
- Do **NOT** dispense towards any person or any part of the body.
- Do **NOT** place hands or fingers over the end of or into the dispense valve.
- Comply with all local, state, and federal fire, electrical and safety regulations
- Use of this product in a manner other than specified in this manual may result in impaired operation or damage to equipment.

⚠ WARNING

This meter is designed specifically to dispense antifreeze (ethylene glycol) solution, windshield wiper fluid, brake fluid and water based solution.

DO NOT USE FOR PETROLEUM PRODUCTS.

METER BUTTONS



Used to enter the batch quantity to be dispensed.

Total 

Used to display the accumulated total of fluid dispensed as well as the re-settable total during Auto Batch and Manual Mode.

Auto 

Used to enter and exit the Manual or Auto Batch mode.



Reset

- Used in the Manual Mode to clear the dispensed quantity.
- Used in Auto Batch Mode to clear the dispensed quantity and reset the meter for the next batch.
- Used to reset the resettable total dispensed while pressing the TOTAL button.



Shut-Off or Stop

Used to stop the flow through an Emergency Override.

LCD DISPLAY

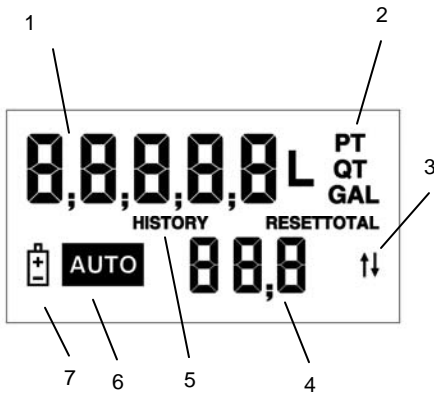

LCD Display

1. Displays re-settable total, accumulated total and Scale Factor
2. Displays Unit of Measure
3. Arrows Notify When in Count Up or Count Down
4. Preset Batch quantity
5. History Icon
6. AUTO is an indicator of unit being in Auto Batch Mode.
7. Low Battery Icon

METER INSTALLATION

Relieve System Pressure

1. Turn off the power supply to the pump or close the shutoff valve.
2. Dispense any fluid in the system into a waste container by opening the meter(s).
3. Open all bleed-type master air valves and fluid meter(s) in the system.
4. Leave the meter(s) open until ready to pressurize the system.

⚠ WARNING

Pressurized Equipment

This equipment stays pressurized until the pressure is manually relieved. To reduce the risk of injury from fluid spray from the meter follow the Pressure Relief Procedures when you:

- Are instructed to relieve pressure
- Stop dispensing
- Check, clean or service any system equipment
- Clean or install nozzles

Grounding

1. Grounding reduces the risk of static sparking. Ground all system components according to local, state and federal codes. Consult the pump user's manual and other system components to ground the following:
 2. Pump: follow manufacturer's recommendations
 3. Air and Fluid Hoses: use only grounded hoses
 4. Air Compressor: follow manufacturers recommendations
 5. Fluid Supply Container: follow the local code

⚠ WARNING

Explosion and Fire

Movement of fluids through the dispensing system creates static electricity. Static electricity can cause volatile fumes resulting in an explosion and fire. The dispensing system must be grounded.

Flushing Procedure

NOTE: *If the system has multiple dispense positions, begin at the position farthest from the pump and move towards the pump.*

⚠ CAUTION

If this installation is new or if the fluid in the lines is contaminated, flush the system before installing the meter(s).

1. Close fluid dispense valves at every position.
2. Once the main fluid outlet valve at the pump is closed and the air pressure to the pump motor is properly adjusted, the air valve is opened.
3. Slowly open the main fluid valve.
4. Place the hose end in a waste container. Make sure hose is secure so no fluid leaks during flushing.
5. Slowly open the dispense valve and allow enough fluid to pass through it to ensure that the system is clean.
6. Close the valve and repeat for all dispense positions.

Apply Meter to Hose

Close the drain valve before starting this procedure.



1. Attach swivel to meter. Apply thread sealant to the male end of the hose. Recommended sealant is Loctite[®] 243.



2. Insert the metal end of the hose into the swivel. Tighten completely with an open ended, adjustable, wrench.

NOTE: *The threaded end of the meter always has female threads. The metal end of the hose must have male threads.*

Apply thread sealant, Loctite[®] 243 or equivalent, to the male end.

The inlet and outlet swivel connections are either 1/2" NPT or 1/2" BSPP, depending on meter model.



Attach the hose

Apply Nozzle to Meter



1. On the opposite end, apply sealant to the end of the nozzle. Recommended sealant is Loctite[®] 243.



2. Thread the nozzle onto the meter. Screw it in tightly with an open-ended, adjustable, wrench.

3. Open all dispense position shut-off valves. Start the pump to pressurize the system.
4. Before use, to ensure accuracy, purge all air from the fluid lines and dispense valve(s).

Attach the Nozzle

METER OPERATION

NOTE: The keypad Auto button is used to toggle between Manual Mode and Auto Batch Mode.

Manual Mode

In the Manual Mode the meter operates as a free flow-dispensing handle.



Manual Mode

1. Pull the trigger to begin the flow.
2. The display shows the amount dispensed.
3. When the desired amount has been dispensed, release the trigger to stop the flow.
4. Press **RESET** button **once** to reset the counter display to zero.

Auto Batch Mode

To enter the Auto Batch Programming Mode, press the **AUTO** button until a digit and colon appear.

This screen appears.



Auto Batch Program Mode

The meter is now ready to select the desired batch number.

- The '0' is flashing in front of the colon. This is the batch number icon.
- Batch '0' is for Manual Mode. (See Manual Mode, above.)
- Batches '1' through '5' are for auto batching amounts up to 99 units.
- Different batch amounts can be stored in each option.
- Batch '6' is for batches between 1 and 999 units.

1. Press the **TOTAL** button to cycle through the batch number icons to select the desired batch or manual mode.

2. When the desired batch number icon appears on screen, change the batch size by pressing the **10**, **1** and **0.1** buttons.



Auto Batch Program Mode, option 1

- Press the 10 button to increase a batch by 10 units.
- Press the 1 button to increase a batch by 1 unit.
- Press the 0.1 button to increase a batch by 0.1 of a unit.



Auto Batch Program Mode, option 6

NOTE: When programming option 6:

- press the 10 button to increase a batch amount in increments of 100 units
- press the 1 button to increase a batch amount in increments of 10 units
- press the 0.1 button to increase a batch amount in increments of 1 unit

NOTE: See the *Count Up/Down Mode Specifications* section of this manual.

3. After the batch size is selected, press the **AUTO** button to lock in the batch and dispense fluid.



4. Pull the trigger to begin the flow.
- The solenoid valve, in the meter, automatically locks the dispensing valve in the full open position.

CAUTION

The meter always locks in the maximum open position.

5. Release the trigger, allowing it to fall back.
6. The flow automatically shuts off after the batch quantity has dispensed.
7. After the batch quantity has been dispensed the meter is a free flow-dispensing handle until the reset button is depressed.

NOTE: In case of an emergency or to interrupt a batch, the meter is equipped with an Emergency Override. (See the *Emergency Override* section of this manual.)

8. The user has the option to top off the fluid at the end of a batch.
 - To top off the fluid, pull the trigger to begin the flow and release it when the desired amount has been pumped.
9. Press the **RESET** button when finished. The display resets and the meter is now ready to dispense the next batch.

Count Up/Count Down Modes

1. When in the Auto Batch Programming Mode, press the **RESET** button and the count up/count down arrows flash in the display.



Count Up Arrow

- Press the **TOTAL** button to toggle between count up/count down.
- Press the **RESET** button to select count up or count down.



Count Down Arrow

NOTE: *In the count up option the meter counts up to the preprogrammed batch amount.*

In the count down option the meter counts from the programmed batch amount down to zero.

Batch number 3 is always in the count down mode.

2. Press the **AUTO** button to lock in the batch quantity when batch size is selected. The screen flashes and the batch number icon no longer displays.



Count Up Mode

- If the meter is in count up mode, the display shows zeros.

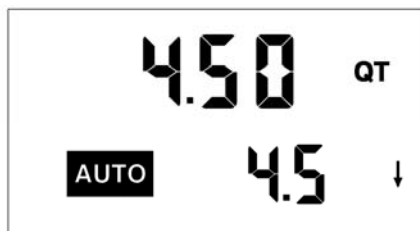

Count Down Mode

- If the meter is in the count down mode, the desired batch size appears on the screen.



OPERATING MODE FUNCTIONS

These functions operate the same in Manual Mode and Auto Batch Mode.

Re-settable/Accumulated Totals



The meter has two flow totalizers. One is Re-settable Total. The other is Accumulated Total.

1. To see the Accumulated Total and the Re-settable Total:

- Press and **hold** the  button to see the Accumulated Total.
- Continue holding the  button.
- After three seconds the screen changes to the Re-settable Total.



Re-settable Total

2. Resettotal displays the total fluid dispensed since the Re-settable Total was last set back to zero.
3. Press the  button while viewing Resettotal to set it back to zero.
4. Release the  button to return to the operating screen.

NOTE: *The Accumulated Total cannot be reset unless the user changes from English units to metric units or from metric to English units. (See the Change Factory Settings, Change Unit of Measure section of this manual).*

Emergency Override

In case of an emergency or to interrupt a batch, the meter is equipped with an Emergency Override.

1. Press the red  button on the meter to activate the Emergency Override.
The override closes the valve, immediately stopping fluid flow.
2. After an Emergency Override, batching can continue by pulling up on the trigger.

History

This option allows the user to review the previous five (5) batches dispensed with the meter.

1. Press and hold the  /**HISTORY** button to view the five (5) previous batches.



History option

- The batches are displayed on screen, one at a time; beginning with the most recent and cycling through to the oldest.
 - The batches continue to cycle as long as the History button is held down.
2. Two (2) seconds after releasing the History button the display automatically returns to the normal operating screen.

NOTE: *The HISTORY cannot be erased unless the user changes from English to metric or from metric to English units. (See the Change Factory Settings section of this manual.)*

Flow Rate

This option allows a user to see instantaneously the rate at which fluid is flowing through the meter.

1. Press and hold the  /**FLOW RATE** button while fluid is flowing through the meter. The Flow Rate appears in the bottom right hand corner of the display.



Flow Rate option

- As long as the button is held down, the Flow Rate remains on the display.
- Releasing the button returns the display to the normal operating screen.

NOTE: *The Flow Rate can only be displayed if fluid is flowing through the meter.*

Error Codes

The meter has one Error Code that may display. It provides an indication, at the meter, that there is an error in communication between the meter and keypad.

SF0 (Scale Factor 0) The Scale Factor setting for the meter is set to 0.000.

- To input a valid Scale Factor for the meter follow the instructions in the *Change Factory Settings* section of this manual.

All other Error Codes are for factory purposes only.

To clear the meter, press Reset.

SERVICE

Low Battery

When the batteries need changing a progression of warnings appears on the meter screen.

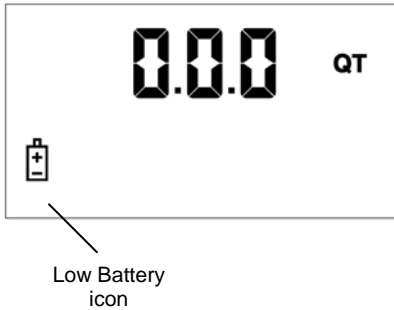

First Warning: the Low Battery icon appears in the lower left corner of the display. That means the batteries are low and need changing.

Second Warning: Battery icon flashes. The battery power is too low and meter functions are disabled.

Changing the Batteries

The battery compartment is located in the lower case on the underside of the trigger guard.

1. Turn the unit over.
2. Unscrew the two screws. Remove the battery door to expose the batteries.
3. Replace the old batteries. The meter takes 4 AA, alkaline, batteries.

NOTE: *Battery polarity markings are inside battery compartment.*

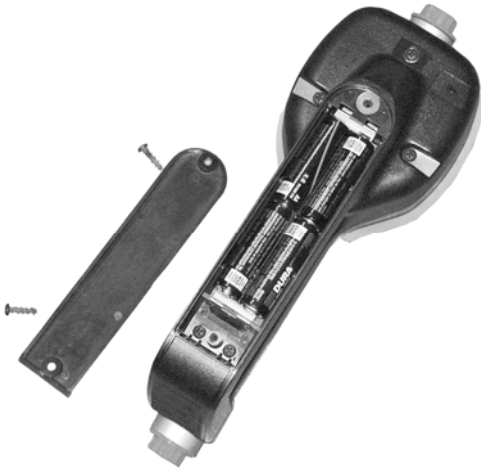

4. Dispose of used batteries properly, according to local regulations.

NOTE: *Changing the batteries does not affect any of the programmed values or totals.*

CHANGE FACTORY SETTINGS

Each meter is calibrated at the factory for use with motor oil (see the *Change Scale Factor* section of this manual). The Unit of Measure is also selected prior to shipment.

Verify Firmware Version

1. The firmware version and code checksum can be displayed by holding the **TOTAL** and **1** button at the same time.
2. The last two digits on the lower right are the firmware version.
3. Meters with version 17 or higher use the procedure outlined in this manual for changing of unit of measure, scale factor and enabling or disabling the EPM functionality.

Programming

To change the factory settings:



1. Push and hold at the same time the **TOTAL** and **AUTO** buttons.
2. PrG will appear on the display.
3. Release the **TOTAL** and **AUTO** buttons.
4. Then press and release in order the **1**, **AUTO**, **10**, **0.1** and the **TOTAL** buttons
5. The current unit of measure will now be flashing indicating that you have entered the programming mode.

Change Unit of Measure

The meter comes with an option to choose 4 different Units of Measure.

Scale Factor Digits

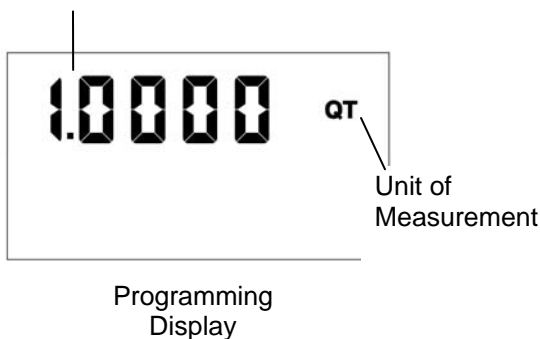

1. The actual Unit of Measure is flashing when the Programming Mode is entered.
2. Press the **TOTAL** button to toggle between the four options; PT, QT, GAL, L.
3. When the desired unit of measure is displayed, press the **RESET** button. The Unit of Measure icon stops flashing.
4. If L, (Liters), is selected, the decimal point begins to flash.
 - You now have the option to change the decimal point to either a period or a comma.
 - To do this, press the **TOTAL** button.
5. If no Scale Factor changes are necessary, refer to the *Save Changes* section of this manual.

CAUTION

Changing the Unit of Measurement from metric to English or from English to metric clears the Re-settable Total and Accumulated Total.

Change Scale Factor

⚠ WARNING

Changing the Scale Factor changes the accuracy of the meter, potentially causing it to overfill or under fill. This has the potential to cause a mechanical breakdown.

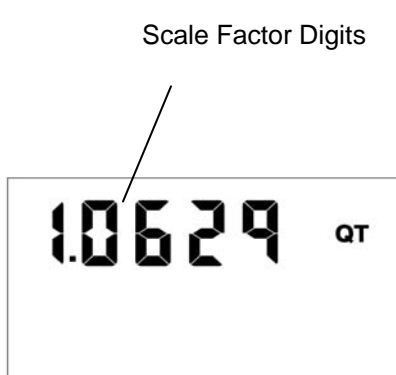

1. Press the **RESET** button to advance through the Scale Factor digits.
2. Press the **TOTAL** button to change the selected number.

NOTE: All digits can be scrolled between 0 and 9 except the first. It can only be scrolled from 0 to 1 or from 1 to 0.

3. Press the **RESET** button to advance to the next number in Scale Factor.
4. Repeat steps 2 and 3 for all five digits in Scale Factor.

Save Changes

To Save Changes and exit the programming mode:

1. Push and hold at the same time the **TOTAL** and **AUTO** buttons.
2. The display will flash 3 times and go blank.
3. Press the **RESET** button and the display will turn back on.

Verify Changes

1. Verify Unit of Measure is correct.
2. Push and hold the Total button and Auto button together, to verify that the Scale Factor is correct.

CALCULATE SCALE FACTOR

A Scale Factor is a number used to adjust meter accuracy. The Scale Factor is set at the factory using motor oil with a viscosity of 10W.

The primary use for Scale Factor recalibration is to batch fluids with different viscosities. If the fluid has a lower viscosity, more fluid can slip past the meter gears without being detected. Changing the Scale Factor adjusts the meter to compensate for the loss.

The meter multiplies each pulse by the Scale Factor number to correct the accuracy when it converts to the specified units. The reading is then always correct.

For an approximate Scale Factor for fluids of different viscosities, consult the charts on the next page.

NOTE: *The meter's original Scale Factor was written on the trigger when it was calibrated at the factory. It may have been revised after field installation. Use the Scale Factor showing on the display, not on the trigger.*

⚠ WARNING

Changing the Scale Factor will change the accuracy of the meter, potentially causing it to overfill or under fill. This has the potential to cause a mechanical breakdown.

To view the current Scale Factor:

1. Press and hold the **TOTAL** button and the **AUTO** button at the same time.

Absolute Scale Factor

For absolute Scale Factor, perform this test:

1. Run a measured amount of fluid through the meter.
2. If the meter delivers 4.20 quarts and the display shows only 4.00 quarts, then the Scale Factor needs to be adjusted.
3. Divide what the meter delivered (4.20) by what the display shows (4.00). You get an error factor of (1.05).
4. The existing Scale Factor is 1.0123, as shown in steps 1 and 2 in "To view the current Scale Factor", above.
5. To calculate a new factor: 1.0123 (existing Scale Factor) \times 1.05 (error factor) = 1.0629 (new Scale Factor).
6. Enter that number as described in the *Change Scale Factor* section of this manual.

NOTE: Use the Scale Factor showing on the display, not on the trigger.

Chart of approximate Scale Factors for fluids of different viscosities

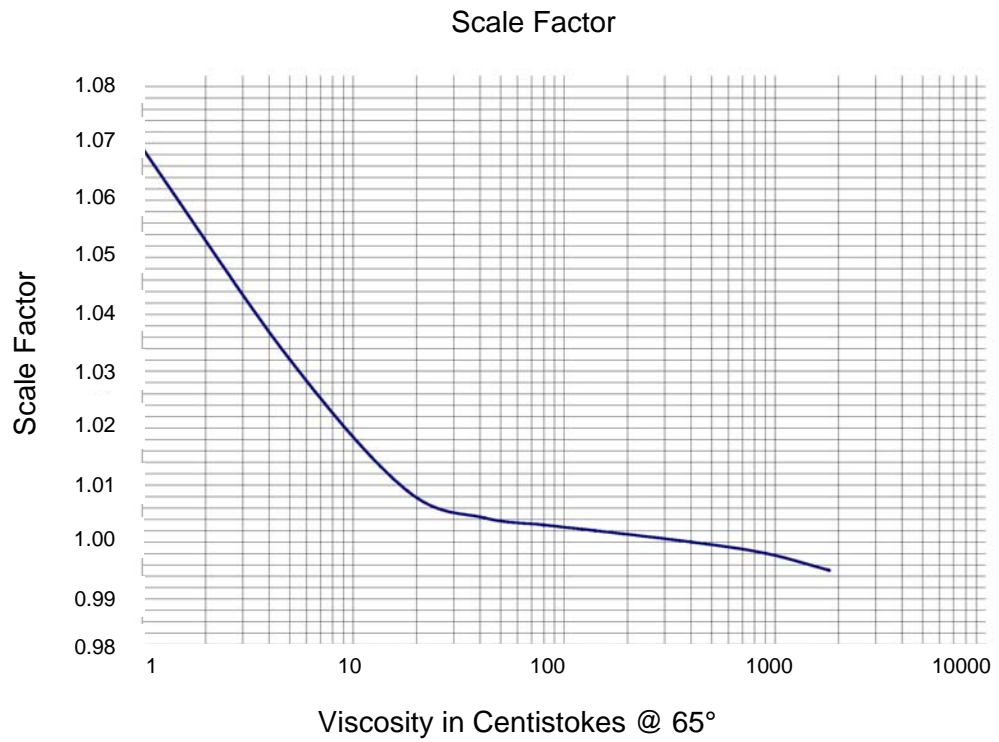

Samples of Fluids, Viscosities and Scale Factors

| | Fluid | Viscosity | Scale Factor |
|---|-------------------|------------------|---------------------|
| 1 | Water/Anti Freeze | 5 | 1.044 |
| 2 | Anti-Freeze | 18 | 1.007 |
| 3 | Brake Fluid | 42 | 1.004 |
| 4 | ATF | 80 | 1.002 |
| 5 | 10W | 140 | 1.000 |
| 6 | 80W-90 | 450 | 0.999 |
| 7 | 140W | 1800 | 0.993 |

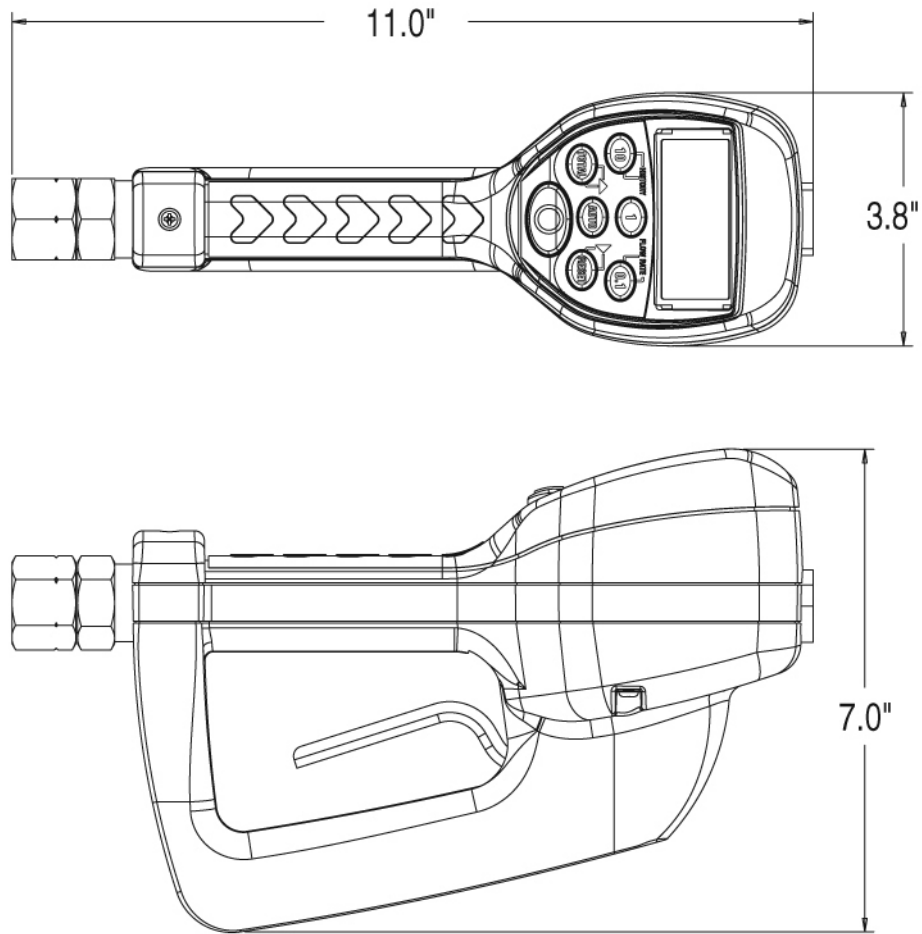

| SPECIFICATIONS | English | Metric |
|---------------------------------|------------------------|---------------|
| Maximum Flow * | 10 gpm | 38 lpm |
| Minimum Flow * | 0.25 gpm | 1 lpm |
| Operating Pressure (Maximum) | 1000 psi | 67 bar |
| Operating Pressure (Minimum) | 5 psi | .35 bar |
| Operating Temperature (Maximum) | 120° F | 50° C |
| Operating Temperature (Minimum) | 20° F | - 5° C |
| Accuracy - General | +/- 0.5% | +/- 0.5% |
| Accuracy - Anti-freeze | +/- 1.5% | +/- 1.5% |
| 5-Digit LCD Display, | Quarts, Pints, Gallons | Liters |
| Inlet and Outlet Connections | ½" NPT | ½" BSPP |

* Min. – Max. flow range will vary with fluid viscosity.

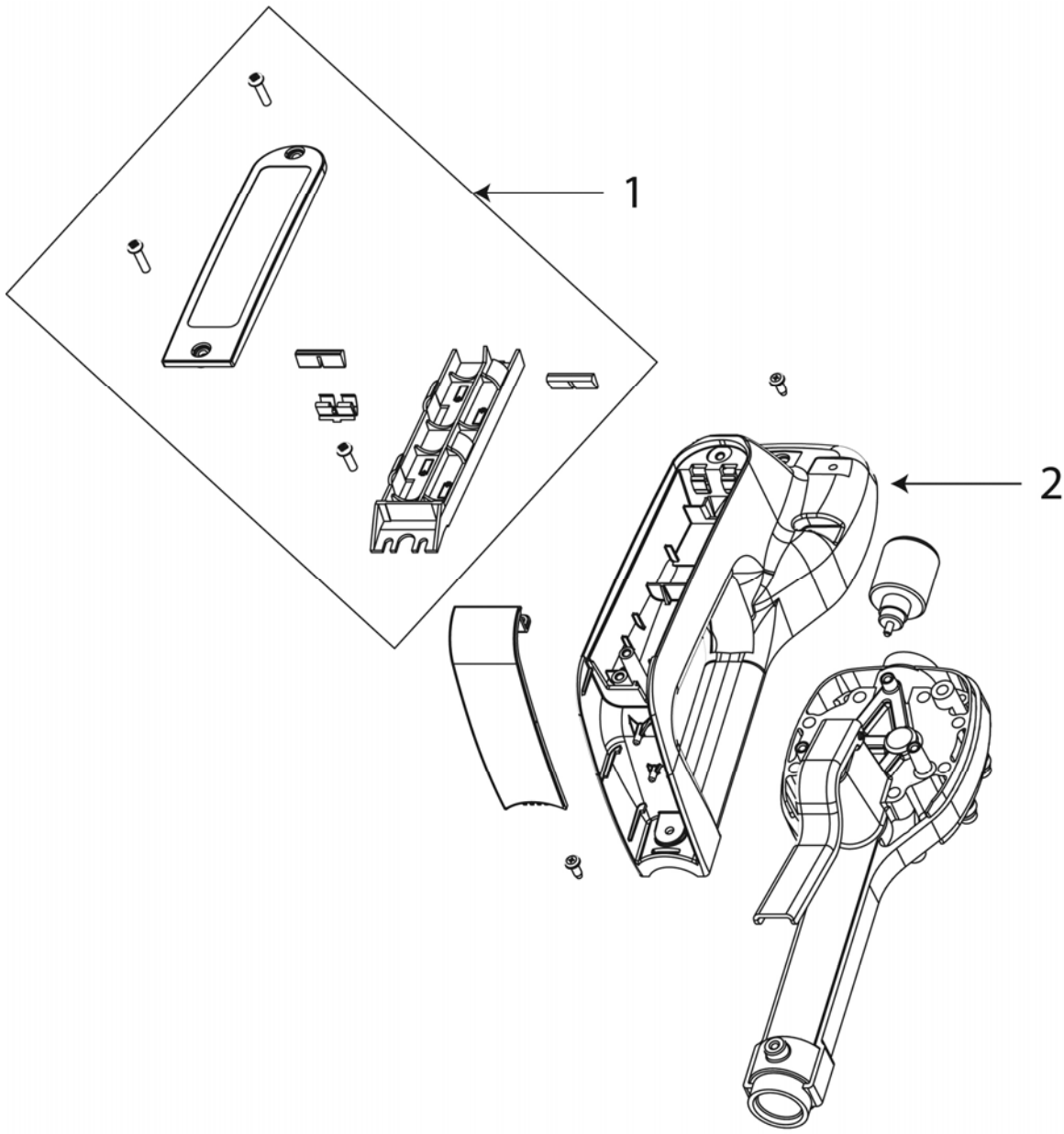

| ITEM # | PART DESCRIPTION | PART NUMBER |
|--------|-------------------------|-------------|
| 1 | Battery Holder Assembly | 64103-026 |
| 2 | Bottom Case with Screws | 64103-003 |

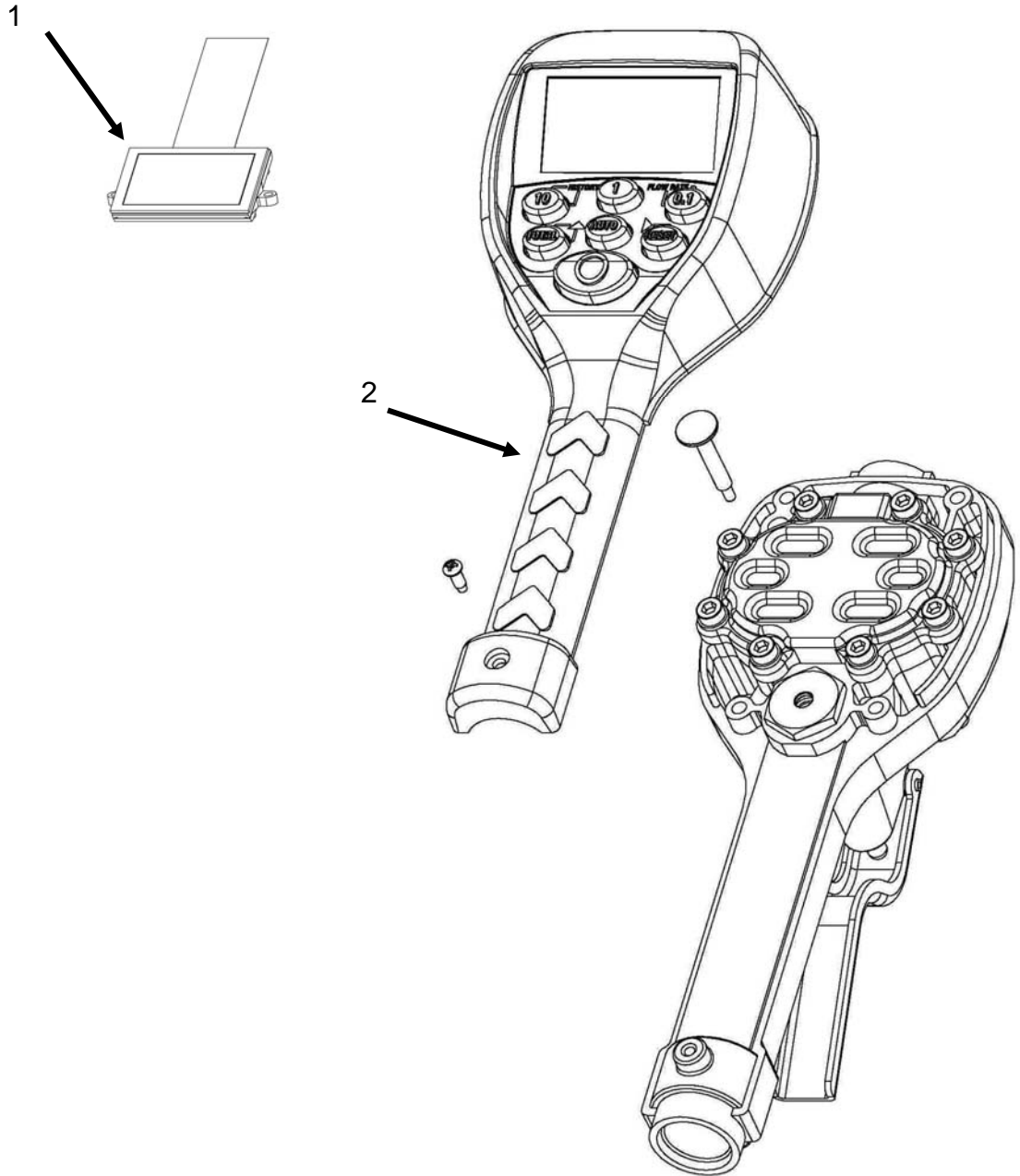

| ITEM # | PART DESCRIPTION | PART NUMBER |
|-----------|-----------------------------|-------------|
| 1 | Display Assembly | 64103-023 |
| 2 | EPM2 Adv. Register Assembly | 64103-025 |
| Not Shown | Swivel, NPT, Special Fluids | 64082-003 |
| Not Shown | Rubber Boot | 65546-001 |

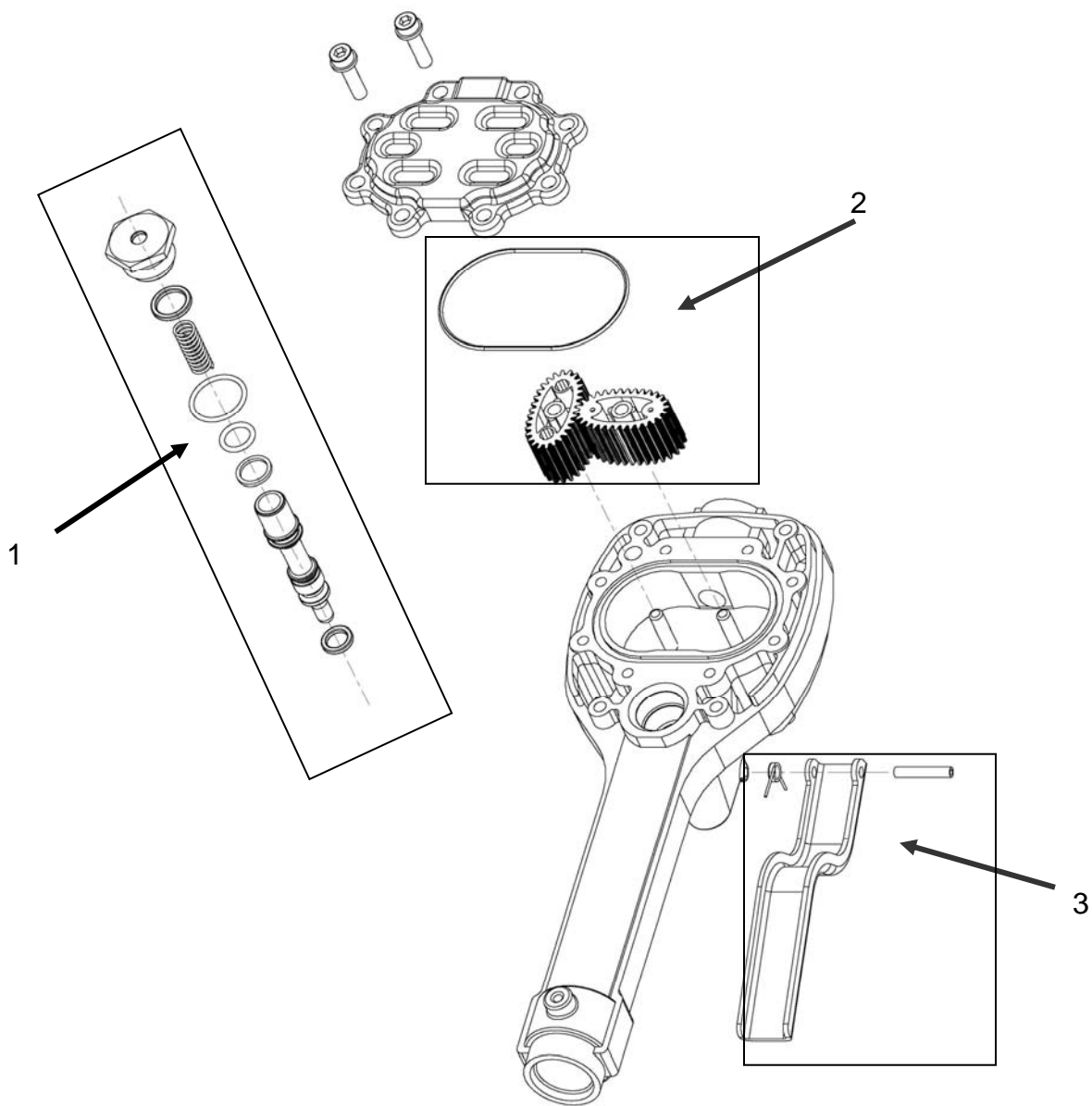

| ITEM # | PART DESCRIPTION | PART NUMBER |
|--------|------------------------------|-------------|
| 1 | Valve Assembly | 64103-011 |
| 2 | Gear Service Kit with O-Ring | 62896-003 |
| 3 | Trigger Assembly | 64103-005 |

TROUBLESHOOTING

WARNING

Relieve the pressure prior to checking or repairing the meter. Make sure all valves, controls and pumps are operating correctly.

| Symptom | Possible Cause | Remedy |
|-----------------------------------|------------------------------------|--|
| Battery Icon is displayed | Batteries are low | Replace batteries |
| Display Blank | Meter asleep | Push reset button |
| | Loose battery connection | Remove battery pack and check battery connection / Push reset button |
| | Batteries dead | Replace batteries / Push reset button |
| Meter does not latch for batching | Meter not in AUTO mode | Press AUTO button and program batch size |
| | Meter not reset after prior batch | Press RESET button |
| | Low batteries | Check for battery icon / replace batteries / push RESET button |
| Slow or no fluid flow | Filter is clogged | Clean or replace the filter in the swivel nut |
| | Pump pressure is low | Turn up the pump pressure |
| | Foreign material is jamming meter | Contact your local distributor for repair |
| Meter inaccurate | Scale factor not correct for fluid | Enter program mode, check and reset program factor |
| Batch overruns program value | Pulse delay value set too low | Enter program mode, reset pulse delay to higher value |

(This page intentionally left blank.)

(This page intentionally left blank.)

(This page intentionally left blank.)

(This page intentionally left blank.)

(This page intentionally left blank.)

Other trademarks appearing in this document are the property of their respective entities.

© 2012 Badger Meter, Inc. All rights reserved.



Due to continuous research, product improvements and enhancements, Badger Meter reserves the right to change product or system specifications without notice, except to the extent an outstanding contractual obligation exists.

Badger Meter | P.O. Box 245036, Milwaukee, Wisconsin 53224-9536
800-876-3837 | infocentral@badgermeter.com | www.badgermeter.com