



Badger Meter

**Electronic Preset Meter 2 Radio Frequency Special
Fluids**

Model EPM2-RF-SF Plus



**IMPORTANT:
This manual contains important information.
READ AND KEEP FOR REFERENCE.**

Disclaimer

The user/purchaser is expected to read and understand the information provided in this manual, follow any listed Safety Precautions and Instructions and keep this manual with the equipment for future reference.

The information in this manual has been carefully checked and is believed to be entirely reliable and consistent with the product described. However, no responsibility is assumed for inaccuracies, nor does Badger Meter, Inc. assume any liability arising out of the application and use of the equipment described.

Should the equipment be used in a manner not specified by Badger Meter, Inc., the protection provided by the equipment may be impaired.

Questions or Service Assistance

If you have questions regarding the product or this document contact:

Badger Meter, Inc.
P.O. Box 245036
Milwaukee, WI 53224-9536

Telephone: (414) 355-0400
(877) 243-1010
Fax: (414) 355-7499
(866) 613-9305

On the Web: www.badgermeter.com
or call your local Badger Meter representative.

Product Identification Information

Record the product identification numbers from the nameplate here.

Model Number _____

Serial Number _____

Tag Number _____ (if applicable)

Table of Contents

DISCLAIMER	Back of front cover
QUESTIONS or SERVICE ASSISTANCE	Back of front cover
PRODUCT IDENTIFICATION INFORMATION	Back of front cover
Table of Contents.....	i
⚠ WARNING Explosions and Fire Hazards	ii
⚠ WARNING Meter Hazards.....	ii
⚠ WARNING Designed for Special Fluids	ii
FCC Compliance.....	ii
METER OVERVIEW	1
Meter Buttons.....	1
LCD Display	2
METER INSTALLATION.....	2
Relieve System Pressure.....	2
Grounding	2
Flushing Procedure	3
Apply Meter to Hose.....	3
Apply Nozzle to Meter	4
METER OPERATION, RF2 MODE.....	4
History Icon	5
Error Codes.....	6
METER OPERATION, EPM MODE.....	7
Manual Mode	7
Batch Mode	7
Return to RF2 Mode	8
OPERATING MODE FUNCTIONS	9
Re-settable/Accumulated Totals	9
Emergency Override	9
SERVICE	10
Low Battery	10
Changing the Battery	10
CHANGE FACTORY SETTINGS	11
Verify Firmware	11
Programming.....	11
Change Unit of Measure	11
Change Scale Factor	12
Manual Mode	12
Save Changes.....	13
Verify Changes.....	13
CALCULATE SCALE FACTOR	14
Absolute Scale Factor.....	14
Chart of Scale Factors	14
Sample Fluids, Viscosities and Scale Factors	14
Specifications.....	15
Parts Drawings.....	16
Troubleshooting	19

⚠ WARNING

EXPLOSION and FIRE HAZARDS

Improper grounding, poor ventilation, open flames or sparks can cause a hazardous condition and result in an explosion or fire and cause serious injury.

- Be sure the fluid system is properly grounded. See your pump instruction manual for details.
- If there is static sparking or if you feel an electric shock while using the meter, stop dispensing immediately. Identify and correct the problem before continuing.
- Provide fresh air ventilation. This will avoid the buildup of fumes from the fluid being dispensed.
- Do not smoke while dispensing flammable fluids.
- Keep the dispensing area free of debris including solvents, rags and spilled gasoline.

⚠ WARNING

METER HAZARDS

Equipment misuse can cause the meter to rupture or malfunction and cause serious injury.

- This equipment is for professional use only.
- Read all instructions, tags and labels before operating the equipment.
- Use the equipment only for its intended purpose.
- Do **NOT** modify or alter the equipment.
- Do **NOT** leave equipment unattended while dispensing.
- Check equipment daily. Repair or replace worn or damaged parts immediately.
- Do **NOT** exceed the maximum working pressure level of the lowest rated system component.
- Use only extensions and nozzles that are designed for use with this equipment.
- Use only fluids and solvents that are compatible with the equipment. Read all fluid and solvent manufacturer's warnings.
- Tighten all fluid connections before operating this equipment.
- Do **NOT** stop or deflect leaks with hands, body, gloves or rags.
- Do **NOT** dispense towards any person or any part of the body.
- Do **NOT** place hands or fingers over the end of or into the dispense valve.
- Comply with all local, state, and federal fire, electrical and safety regulations
- Use of this product in a manner other than specified in this manual may result in impaired operation or damage to equipment.

⚠ WARNING

This meter is designed specifically to dispense antifreeze (ethylene glycol) solution, windshield wiper fluid, brake fluid and water based solution.

DO NOT USE FOR PETROLEUM PRODUCTS.

**FCC ID: GIF-RF2 KEYPAD
FCC CERTIFIED, PART 15, SUB-PART C**

This device complies with Part 15 of the FCC Rules. Operation is subject to the following two conditions: (1) this device may not cause harmful interference, and (2) this device must accept any interference received, including interference that may cause undesired operation.

METER OVERVIEW

The Electronic Preset Meter RF2 (EPM RF2) is equipped with RF (radio frequency) communications to communicate with a fluid management system keypad to get authorization and dispense information. This is referred to in the manual as the RF2 Mode.

The meter can also be run as a standard EPM. This is referred to in the manual as the EPM Mode. This is intended for start-up purposes or when the fluid management system is not in use.

Once a work order has been entered at the keypad, the operator simply pushes the  button on the meter to start communications between the meter and the keypad. The meter receives authorization from the keypad to unlock and the dispense batch quantity. When the trigger is pulled the pre-set dispense batch quantity dispenses.

The meter automatically shuts off when the dispense batch quantity has been reached.

A "Top Off" feature allows additional fluid to be dispensed and tracked after the batch quantity has been dispensed.

Upon completion of the dispense, the operator presses the  button. The meter then locks, prohibiting any unauthorized dispense of fluid to occur, and the dispense quantity is sent to the keypad.

Meter Buttons



Meter Display



Used to enter the dispense Batch quantity when in the EPM Mode. These buttons are **NOT** used in RF2 Mode.



Total

Used to display the accumulated total of fluid dispensed, as well as the re-settable total.



Auto

Used to enter and exit the manual or batch mode when in EPM mode. This button is **NOT** used in RF2 mode.



Reset

- Used to initiate RF2 communications from the meter to the Keypad.
- Used in EPM mode to clear the previous batch.
- Used to reset the re-settable total dispensed while pressing the TOTAL button.

Shut-Off or Stop



Used to stop the flow through an Emergency Override.

LCD Display

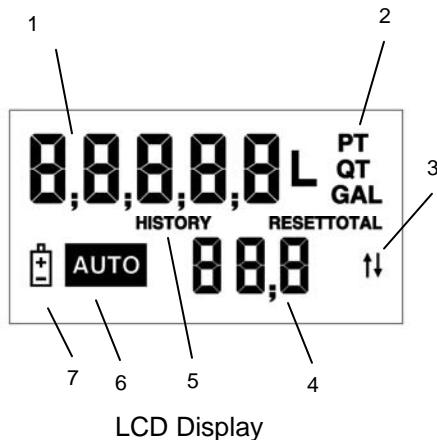

1. Displays re-settable total, accumulated total and Scale Factor
2. Displays Unit of Measure
3. Arrows flash when RF communication is in progress with the keypad
4. Preset Batch quantity
5. History Icon
6. AUTO is an indicator of being in EPM mode
7. Low Battery Icon

METER INSTALLATION

Relieve System Pressure

1. Turn off the power supply to the pump or close the shutoff valve.
2. Dispense any fluid in the system into a waste container by opening the meter(s).
3. Open all bleed-type master air valves and fluid meter(s) in the system.
4. Leave the meter(s) open until ready to pressurize the system.

⚠ WARNING

Pressurized Equipment

This equipment stays pressurized until the pressure is manually relieved. To reduce the risk of injury from fluid spray from the meter follow the Pressure Relief Procedures when you:

- Are instructed to relieve pressure
- Stop dispensing
- Check, clean or service any system equipment
- Clean or install nozzles

Grounding

1. Grounding reduces the risk of static sparking. Ground all system components according to local, state and federal codes. Consult the pump user's manual and other system components to ground the following:
2. Pump: follow manufacturer's recommendations
3. Air and Fluid Hoses: use only grounded hoses
4. Air Compressor: follow manufacturers recommendations
5. Fluid Supply Container: follow the local code

⚠ WARNING

Explosion and Fire

Movement of fluids through the dispensing system creates static electricity. Static electricity can cause volatile fumes resulting in an explosion and fire. The dispensing system must be grounded.

Flushing Procedure

NOTE: *If the system has multiple dispense positions, begin at the position farthest from the pump and move towards the pump.*

⚠ CAUTION

If this installation is new or if the fluid in the lines is contaminated, flush the system before installing the meter(s).

1. Close fluid dispense valves at every position.
2. Once the main fluid outlet valve at the pump is closed, the air pressure to the pump motor is properly adjusted and the air valve is opened.
3. Slowly open the main fluid valve.
4. Place the hose end in a waste container. Make sure hose is secure so no fluid leaks during flushing.
5. Slowly open the dispense valve and allow enough oil to pass through it to ensure that the system is clean.
6. Close the valve and repeat for all dispense positions.

Apply Meter to Hose

Close the drain valve before starting this procedure.



1. Attach a swivel to the meter. Apply thread sealant to the male end of hose. Recommended sealant is Loctite[®] 243.



2. Insert the metal end of the hose into the swivel. Tighten completely with an open-ended, adjustable, wrench.

NOTE: *The threaded end of the meter always has female threads. The metal end of the hose must have male threads.*

Apply thread sealant, Loctite[®] 243, or equivalent, to the male end.

The inlet and outlet swivel connections are either 1/2" NPT or 1/2" BSPP, depending on meter model.



Attach the hose

Apply Nozzle to Meter



Attach the Nozzle

1. On the opposite end, apply sealant to the end of the nozzle. Recommended sealant is Loctite[®] 243.
2. Thread the nozzle onto the meter. Screw it in tightly with an open ended, adjustable, wrench.
3. Open all dispense position shut-off valves. Start the pump to pressurize the system.
4. Before use, to ensure accuracy, purge all air from the fluid lines and dispense valve(s).

METER OPERATION, RF MODE

When the battery pack is attached to the meter, it automatically enters the RF Mode.

The trigger is in the locked-out position. No fluid can be dispensed by the meter until a dispense order is received from the keypad.



Arrows



Batch
Quantity

1. Pressing the meter **RESET** button causes communication to occur between the meter and the keypad.
 - Two (2) arrows in the lower right hand corner of the meter screen flash. This indicates communication is in progress between the meter and keypad.
2. When the communication is complete the trigger unlocks and the batch quantity is displayed.

3. Pull the trigger to the full, up, position to begin the fluid flow.
- The solenoid valve, in the meter, automatically locks the dispensing valve in the full open position. The trigger falls back to the closed position.
 - It is not necessary to continue to hold the trigger.
 - After the batch quantity is dispensed, the flow automatically shuts off.

4. The user has the option to top off the tank after the batch quantity has been dispensed.
- To top off, pull the trigger to begin the flow.
 - Release the trigger when the desired amount has been dispensed.

CAUTION

Do **NOT** press  button before topping off.

If  button is pressed, the meter returns to a locked-out position and does not allow additional fluid to be dispensed until a valid dispense order is received from the RF2 System.

5. When finished, press the  button to complete the dispense order.
- The total quantity dispensed is transmitted to the RF2 system.
 - The meter returns to the locked position.
 - The meter is now ready to receive another dispense order from the RF2 system.

NOTE: *If the original communication fails, the meter automatically attempts to communicate with the RF2 system by resending the Dispense Result three (3) times, 30 seconds apart.*

6. If the meter is unable to communicate a dispense result, the History icon lights.

History Icon



History Icon

The History icon indicates there is dispense result information that has not been communicated to the keypad to complete a work order.

To send the dispense result information to the keypad, press  button to initiate communication.

Error Codes

The meter has several Error Codes that may display. These provide indication, at the meter, that there is an error in communication between the meter and keypad.

F01 The meter has received an invalid response from the keypad.

- To clear the error, press the Reset button on the meter.
- Press the Reset button a second time to retry communications with the keypad.

F02 The meter has not received a response from the keypad during communications.

- To clear the error code, press the Reset button on the meter.
- To retry communications with the keypad, press the Reset button a second time.
- There may be an obstruction blocking the RF2 signal between the meter and keypad. It may be necessary to change your physical location.

F04 There is a damaged cable assembly within the meter.

- This meter should be taken out of service.
 - This meter may be used reliably in EPM Mode.
- RF2 Mode will exhibit erratic behavior.

SF0 (Scale Factor 0) The Scale Factor setting for the meter is set to 0.000.

- To input a valid Scale Factor for the meter follow the instructions in the *Change Factory Settings* section of this manual.

All other Error Codes are for factory purposes only.

- To clear the meter, press Reset.

METER OPERATION, EPM MODE

The meter can be put in EPM Mode. For start up purposes, refer to the Supervisor's Instruction Manual for key sequence.

The AUTO icon displays, indicating the meter is in the EPM Mode. The solenoid valve unlocks and the meter can now be used as a Standard Preset Batch Meter.

NOTE: *The keypad Auto button is used to toggle between Manual Mode and Batch Mode.*

Manual Mode



EPM Manual Mode

1. Pull the trigger to begin the flow.
2. The display shows the amount dispensed.
3. When the desired amount has been dispensed, release the trigger to stop the flow.
4. Press  button **once** to reset the counter display to zero.



Batch Mode



EPM Batch Mode

To enter the Batch Mode from the Manual Mode press the meter  button. The screen on the left appears. When in the Batch Mode, the batch quantity displays in the lower, right hand corner of the screen.

The meter is now in Batch Mode.

1. Change the batch size by pressing the ,  and/or  buttons.
 - a) Press the 10 button to increase the batch amount in increments of 10 units.
 - b) Press the 1 button to increase the batch amount in increments of 1 unit.
 - c) Press the 0.1 button to increase the batch amount in increments of 0.1 units.

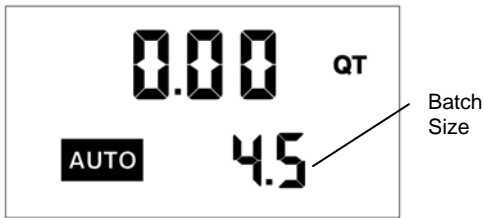

2. Pull the trigger to begin the flow.
 - The meter solenoid valve automatically locks the dispensing valve in the full open position. The trigger falls back to the closed position.

⚠ CAUTION
The meter always locks in the maximum open position.

- After the batch quantity is dispensed, the flow automatically shuts off.

NOTE: For RF2 and BATCH programming, the meter automatically shuts off if the trigger is pulled and the meter does not sense any flow.

Also, in case of an emergency or to interrupt a batch, the meter is equipped with an Emergency Override. (See the Emergency Override section of this manual)

3. The user has the option to top off the fluid at the end of a batch.
 - To top off the fluid, pull the trigger to begin the flow and release it when the desired amount has been pumped.
4. Press the **RESET** button when finished. The display resets and the meter is now ready for the next batch to be dispensed.

Return to RF Mode



To return to the RF Mode from the EPM Mode:

1. Press **RESET** button **twice**. You'll see the flashing arrows indicating the meter is communicating with the RF2 System.
2. When communication is complete, the meter returns to the RF2 Mode and the trigger locks.



OPERATING MODE FUNCTIONS

These functions operate the same in RF2 Mode and EPM Mode.

Re-settable/Accumulated Totals

The meter has two flow totalizers. One is Re-settable Total the other is Accumulated Total.

1. To see the Accumulated Total and the Re-settable Total:

- Press and **hold** the  button to see the Accumulated Total.
- Continue holding the  button.
- After three seconds the screen changes to the Re-settable Total.



Re-settable Total

2. Resettotal displays the total fluid dispensed since the Re-settable Total was last set back to zero.

3. Press the  button while viewing Resettotal to set it back to zero.

4. Release the  button to return to the operating display.

NOTE: *The Accumulated Total cannot be reset unless the user changes from English units to metric units or from metric to English units. (See the Change Factory Settings, Change Unit of Measure section of this manual).*

Emergency Override

In case of an emergency or to interrupt a batch, the meter is equipped with an Emergency Override.

1. Press the red  button to activate the Emergency Override.
The override closes the valve, immediately stopping fluid flow.
2. Batching can continue after an Emergency Override by pulling up on the trigger.

SERVICE

Low Battery

When the batteries need changing a progression of warnings appears on the meter screen.



Low Battery
icon

First Warning: the Low Battery icon appears in the lower left corner of the display. That means the batteries are low and need to be changed when the icon appears.

Second Warning: Battery icon flashes. The battery power is too low and meter functions are disabled.

Changing the Batteries

The battery compartment is located in the lower case on the underside of the trigger guard.

1. Turn the unit over.
2. Unscrew the two screws. Remove the battery door to expose the batteries.
3. Replace the old batteries. The meter takes 4 AA, alkaline, batteries.

NOTE: *Battery polarity markings are inside battery compartment.*

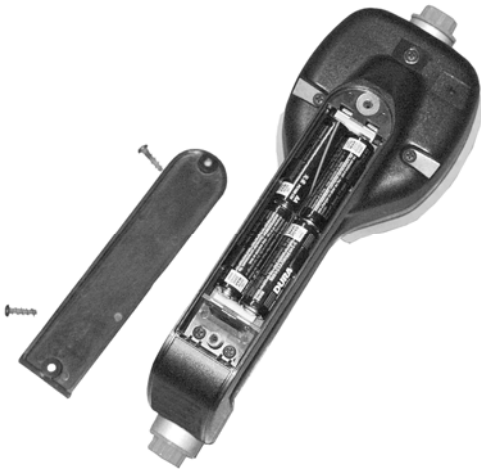

4. Dispose of used batteries properly, according to local regulations.

NOTE: *Changing the batteries does not affect any of the programmed values or totals.*

CHANGE FACTORY SETTINGS

Each meter is calibrated at the factory for use with motor oil (see the *Change Scale Factor* section of this manual). The Unit of Measure is also selected prior to shipment.

Verify Firmware Version

1. The firmware version and code checksum can be displayed by holding the **TOTAL** and **1** button at the same time.
2. The last two digits on the lower right are the firmware version.
3. Meters with version 18 or higher use the procedure outlined in this manual for changing of unit of measure, scale factor and enabling or disabling the EPM functionality.

Programming

To change the factory settings:



1. Push and hold at the same time the **TOTAL** and **AUTO** buttons.
2. PrG will appear on the display.
3. Release the **TOTAL** and **AUTO** buttons.
4. Then press and release in order the **1**, **AUTO**, **10**, **0.1** and the **TOTAL** buttons
5. The current unit of measure will now be flashing indicating that you have entered the programming mode.

Change Unit of Measure

The meter comes with an option to choose 4 different Units of Measure.

Scale Factor Digits

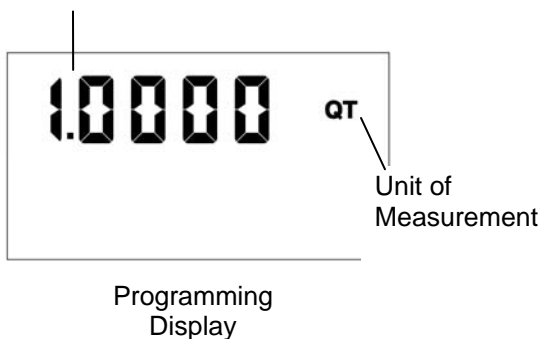

1. The actual Unit of Measure is flashing when the Programming Mode is entered.
2. Press the **TOTAL** button to toggle between the four options; PT, QT, GAL, L.
3. When the desired unit of measure is displayed, press the **RESET** button. The Unit of Measure icon stops flashing.
4. If L, (Liters), is selected, the decimal point begins to flash.
 - You now have the option to change the decimal point to either a period or a comma.
 - To do this, press the **TOTAL** button.
5. If no Scale Factor changes are necessary, refer to the *Save Changes* section of this manual.

CAUTION

Changing the Unit of Measurement from metric to English or from English to metric clears the Re-settable Total and Accumulated Total.

Change Scale Factor

⚠ WARNING

Changing the Scale Factor changes the accuracy of the meter, potentially causing it to overfill or under fill. This has the potential to cause a mechanical breakdown.

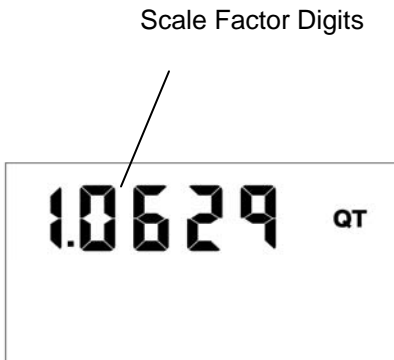

1. Press the **RESET** button to advance through the Scale Factor digits.
2. Press the **TOTAL** button to change the selected number.

NOTE: All digits can be scrolled between 0 and 9 except the first. It can only be scrolled from 0 to 1 or from 1 to 0.

3. Press the **RESET** button to advance to the next number in Scale Factor.
4. Repeat steps 2 and 3 for all five digits in Scale Factor.

EPM (MANUAL) Mode enable/disable

To disable or enable the EPM mode of the meter:

1. Press the (reset) button to advance to the AUTO icon on the display, there will be no other icons flashing on the display.
2. Then press the (auto) button to toggle on and off the AUTO icon. When the icon is turned on the meter can be put in EPM mode through the special key sequence on the meter keypad. When the AUTO icon is turned off the key sequence is disabled and the meter cannot be put in EPM mode.



Save Changes

To Save Changes and exit the programming mode:

1. Push and hold at the same time the **TOTAL** and **AUTO** buttons.
2. The display will flash 3 times and go blank.
3. Press the **RESET** button and the display will turn back on.

Verify Changes

1. Verify Unit of Measure is correct.
2. Push and hold the **TOTAL** button and **AUTO** button together, to verify that the Scale Factor is correct.

CALCULATE SCALE FACTOR

A Scale Factor is a number used to adjust meter accuracy. The Scale Factor is set at the factory using motor oil with a viscosity of 10W.

The primary use for Scale Factor recalibration is to batch fluids with different viscosities. If the fluid has a lower viscosity, more fluid can slip past the meter gears without being detected. Changing the Scale Factor adjusts the meter to compensate for the loss.

The meter multiplies each pulse by the Scale Factor number to correct the accuracy when it converts to the specified units. The reading is then always correct.

For an approximate Scale Factor for fluids of different viscosities, consult the charts on the next page.

NOTE: *The meter's original Scale Factor was written on the trigger when it was calibrated at the factory. It may have been revised after field installation. Use the Scale Factor showing on the display, not on the trigger.*

⚠ WARNING

Changing the Scale Factor will change the accuracy of the meter, potentially causing it to overfill or under fill. This has the potential to cause a mechanical breakdown.

To view the current Scale Factor:

1. Press and hold the **TOTAL** button and the **AUTO** button at the same time.

Absolute Scale Factor

For absolute Scale Factor, perform this test:

1. Run a measured amount of fluid through the meter.
2. If the meter delivers 4.20 quarts and the display shows only 4.00 quarts, then the Scale Factor needs to be adjusted.
3. Divide what the meter delivered (4.20) by what the display shows (4.00). You get an error factor of (1.05).
4. The existing Scale Factor is 1.0123, as shown in steps 1 and 2 in “To view the current Scale Factor”, above.
5. To calculate a new factor: 1.0123 (existing Scale Factor) \times 1.05 (error factor) = 1.0629 (new Scale Factor).
6. Enter that number as described in the *Change Scale Factor* section of this manual.

NOTE: Use the Scale Factor showing on the display, not on the trigger.

Chart of approximate Scale Factors for fluids of different viscosities

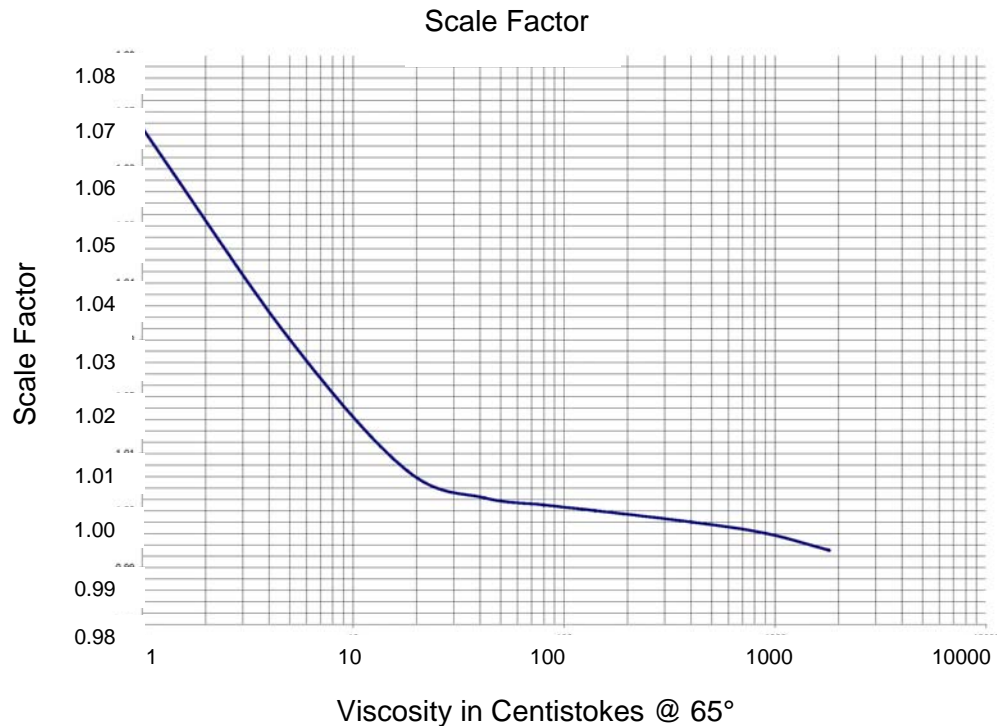

Samples of Fluids, Viscosities, and Scale Factors

	Fluid	Viscosity	Scale Factor
1	Water/Anti Freeze	5	1.044
2	Anti-Freeze	18	1.007
3	Brake Fluid	42	1.004
4	ATF	80	1.002
5	10W	140	1.000
6	80W-90	450	0.999
7	140W	1800	0.993

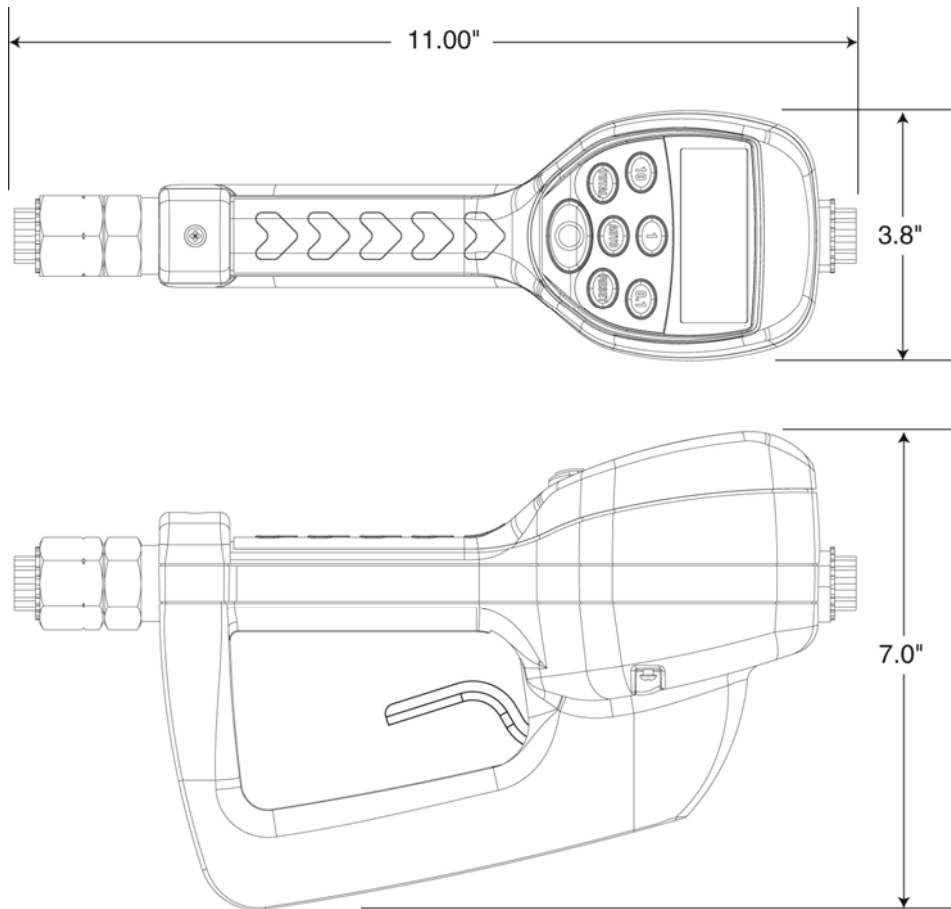

SPECIFICATIONS	English	Metric
Maximum Flow *	10 gpm	38 lpm
Minimum Flow *	0.25 gpm	1 lpm
Operating Pressure (Maximum)	1000 psi	67 bar
Operating Pressure (Minimum)	5 psi	.35 bar
Operating Temperature (Maximum)	120° F	50° C
Operating Temperature (Minimum)	20° F	- 5° C
Accuracy - General	+/- 0.5%	+/- 0.5%
Accuracy - Anti-freeze	+/- 1.5%	+/- 1.5%
5-Digit LCD Display, 10 mm High x 5 mm Wide	Quarts, Pints, Gallons	Liters
Inlet and Outlet Connections	½" NPT	½" BSPP

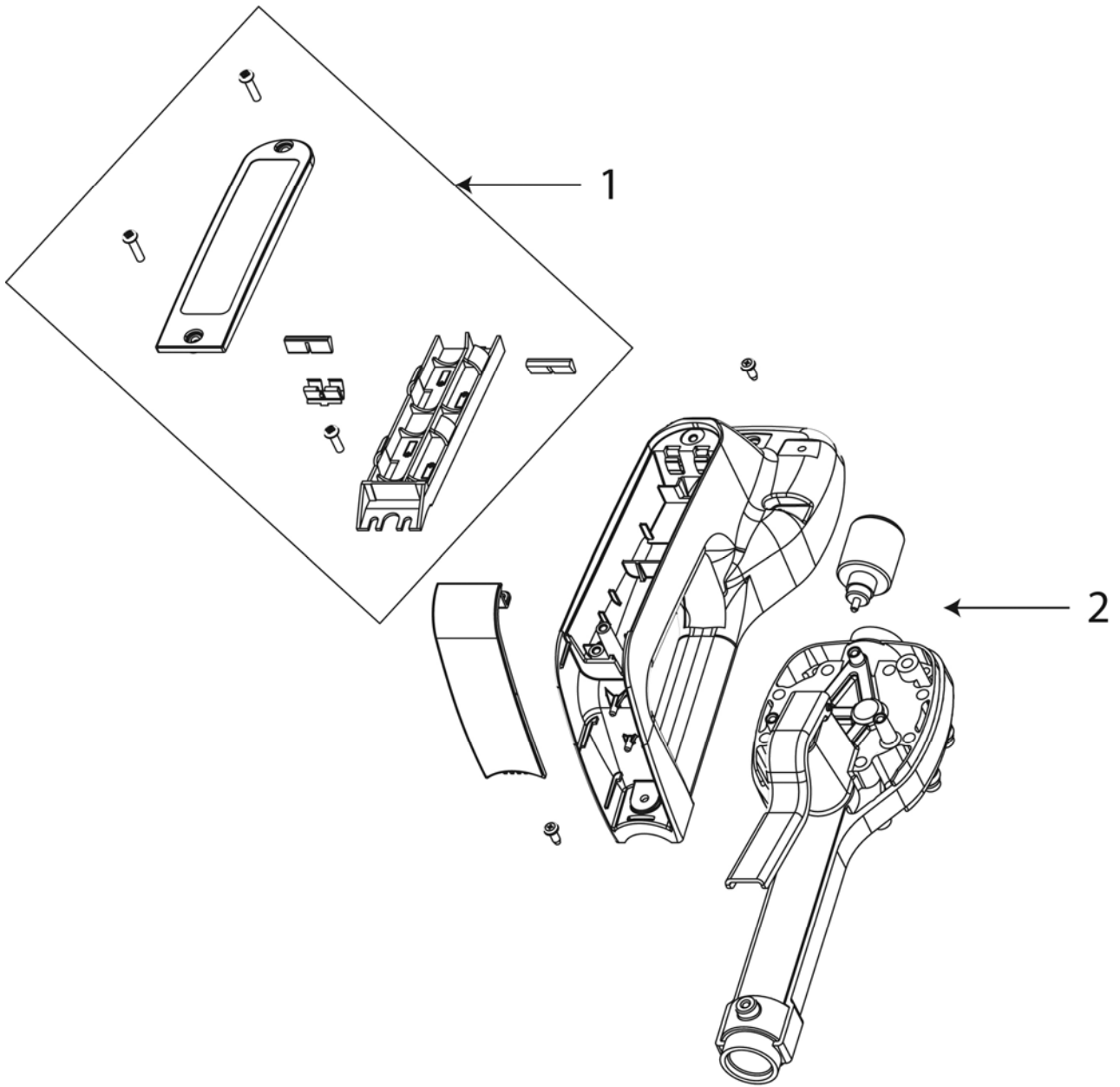

ITEM #	PART DESCRIPTION	PART NUMBER
1	Battery Holder Assembly	64103-026
2	Bottom Case with Screws	64103-021

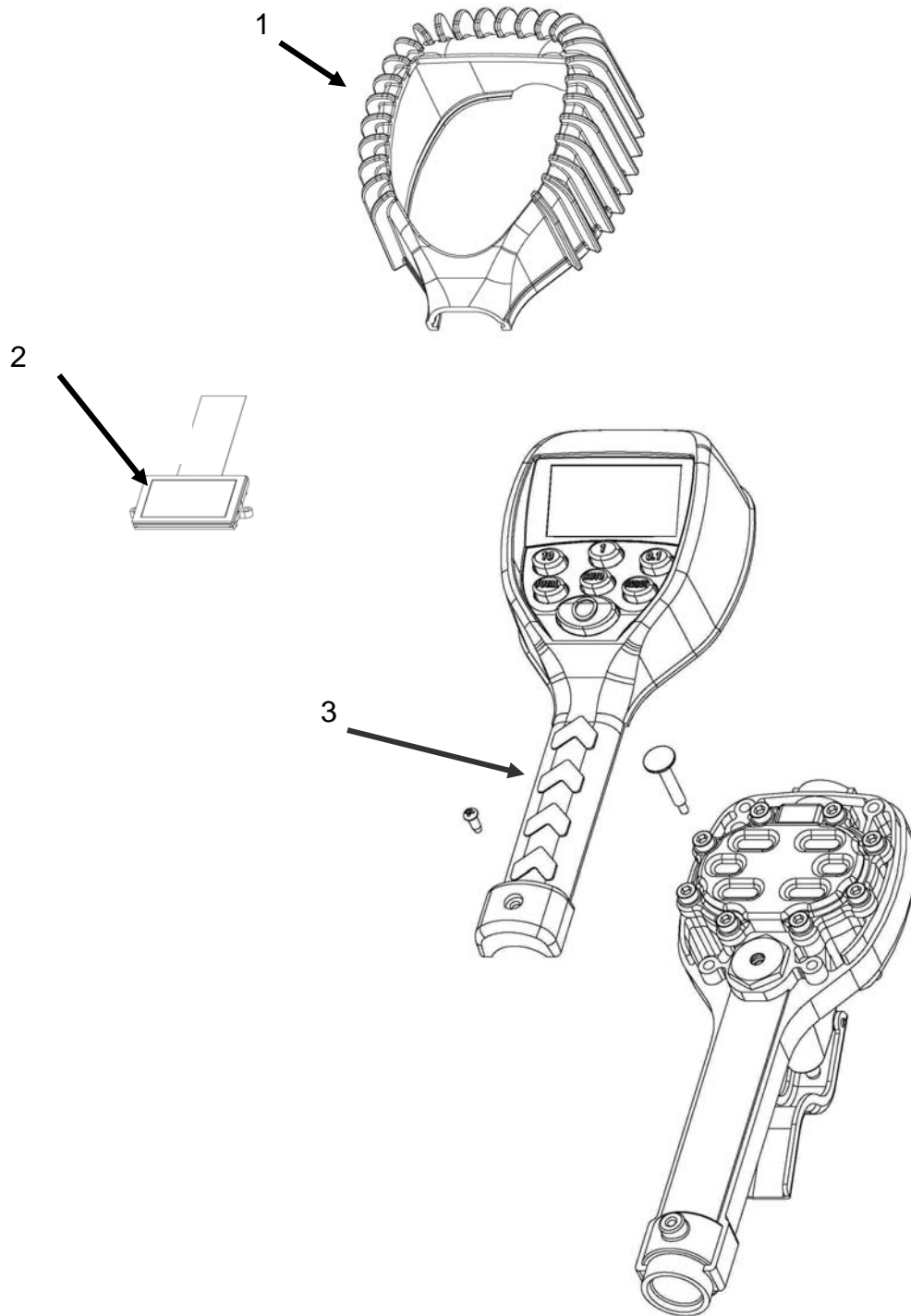

ITEM #	PART DESCRIPTION	PART NUMBER
1	Rubber Boot	66546-001
2	Display Assembly	64103-023
3	RF Register Assembly	64103-022
Not Shown	Swivel, NPT, Special Fluids	64082-003

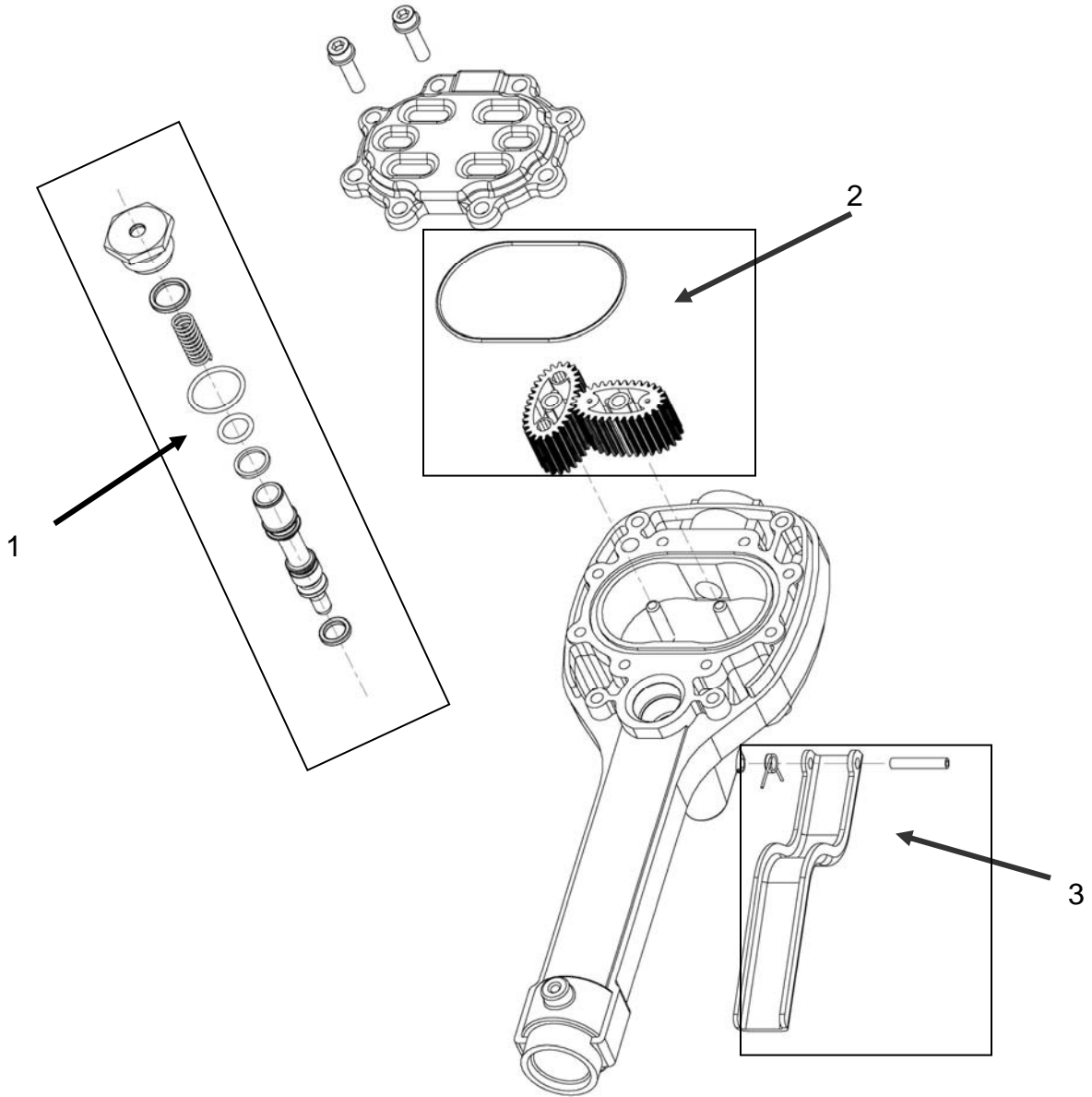

ITEM #	PART DESCRIPTION	PART NUMBER
1	Valve Assembly	64103-009
2	Gear Service Kit with O-Ring	62896-003
3	Trigger Assembly	64103-015

TROUBLESHOOTING

WARNING

Relieve the pressure prior to checking or repairing the meter. Make sure all valves, controls and pumps are operating correctly.

Symptom	Possible Cause	Remedy
Battery Icon is displayed	Batteries are low	Replace batteries
Display Blank	Meter asleep	Push reset button
	Loose battery connection	Remove battery pack and check battery connection / Push reset button
	Batteries dead	Replace batteries / Push reset button
Meter does not latch for batching	Meter not in AUTO mode	Press AUTO button and program batch size
	Meter not reset after prior batch	Press RESET button
	Low batteries	Check for battery icon / replace batteries / push RESET button
Slow or no fluid flow	Filter is clogged	Clean or replace the filter in the swivel nut
	Pump pressure is low	Turn up the pump pressure
	Foreign material is jamming meter	Contact your local distributor for repair
Meter inaccurate	Scale factor not correct for fluid	Enter program mode, check and reset program factor
Batch overruns program value	Pulse delay value set too low	Enter program mode, reset pulse delay to higher value

Other trademarks appearing in this document are the property of their respective entities.

© 2012 Badger Meter, Inc. All rights reserved.



Due to continuous research, product improvements and enhancements, Badger Meter reserves the right to change product or system specifications without notice, except to the extent an outstanding contractual obligation exists.

Badger Meter | P.O. Box 245036, Milwaukee, Wisconsin 53224-9536
800-876-3837 | infocentral@badgermeter.com | www.badgermeter.com