



Badger Meter

Oval Gear Transmitter High Flow Model OGT-HF-SF 1 inch

GENERAL

The Model OGT High Flow meter is designed to handle flow rates up to 30 GPM. The meter is designed specifically to dispense antifreeze (Ethylene Glycol), engine coolant, brake fluid, wiper fluid and water-based fluids. Modular design, compact foot print and rugged design make the OGT the best choice for automated dispensing systems.

The transmitter mounted on the meter can be wired to batch controllers, remote counters and other electronically operated instruments that can accept pulses from a reed switch and have scaling capabilities. The oval gear transmitter is contained in a plastic housing.

OPERATION

As fluid passes through the metering chamber by entering the inlet port, the internal gears rotate forcing the fluid to exit through the outlet port. Each rotation of the gear displaces a given volume of fluid. Controlled clearances between the gears and chamber wall insure minimum leakage.

As the gears rotate, a magnet on each end of the gear causes the reed switch to open and close. Contact closures from the switch are transmitted to a remote batch controller or counter.

APPLICATIONS

This transmitter is normally connected to metering systems that have scaling capabilities and that can accept a reed switch pulse.

Typical applications are batching systems and other applications that require totalizing meter flow and monitoring rate of fluid flow passing through the meter.

CAUTION

The use of meters in applications other than those described in this material may result in inaccuracy and possible meter failure. It is important that fluids be properly filtered before entering the meter. Foreign particles will cause inaccuracy as well as possible malfunction of the meter. Warranties are void in the circumstances described above.



FEATURES

- 1 inch threads (NPT or BSP available)
- Compact foot print
- Oval gear driven meter
- Does not require external power
- Rugged, corrosion resistant plastic enclosure
- Hermetically sealed reed switch output
- Humidity and moisture resistant transmitter
- Compatible with most flow controllers and counters with scaling capabilities
- Accuracy to $\pm 0.75\%$

DIMENSIONAL DRAWING

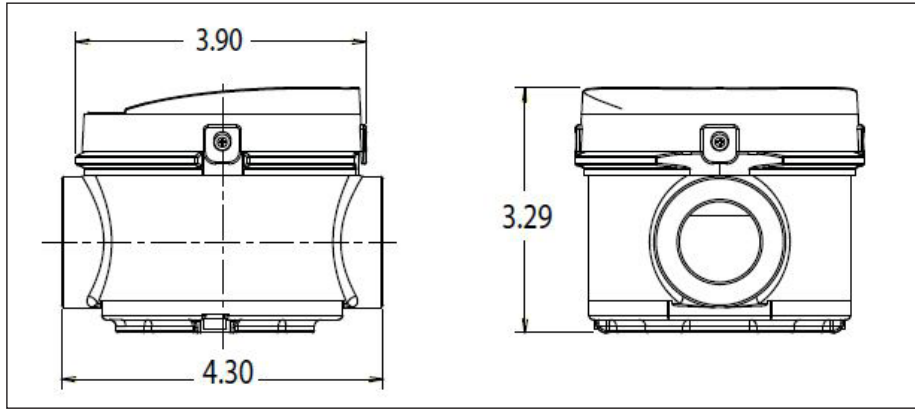

SPECIFICATIONS

	OG Meter	
	English	Metric
Maximum Flow	30 gpm	115 liters/minute
Minimum Flow	0.80 gpm	3.0 liters/minute
Operating Pressure (Maximum)	1500 psi	103 bar
Operating Pressure (Minimum)	5 psi	.35 bar
Operating Temperature (Maximum)	140°F	60°C
Operating Temperature (Minimum)	-20°F	-30°C
Accuracy	+/- 0.75%	+/- 0.75%
Weight	1.8 lbs.	0.82 kg
Inlet & Outlet Connections	1" NPTF	1" BSPP
Reed Switch Rating	120 VAC @10 Watts	120 VAC @10 Watts

PULSES PER UNIT

Unit of Measure	Pulses
Liter	66.75
Gallon	252.68
Quart	63.17

**Pressure Drop
1" High Flow Oval Gear Meter**

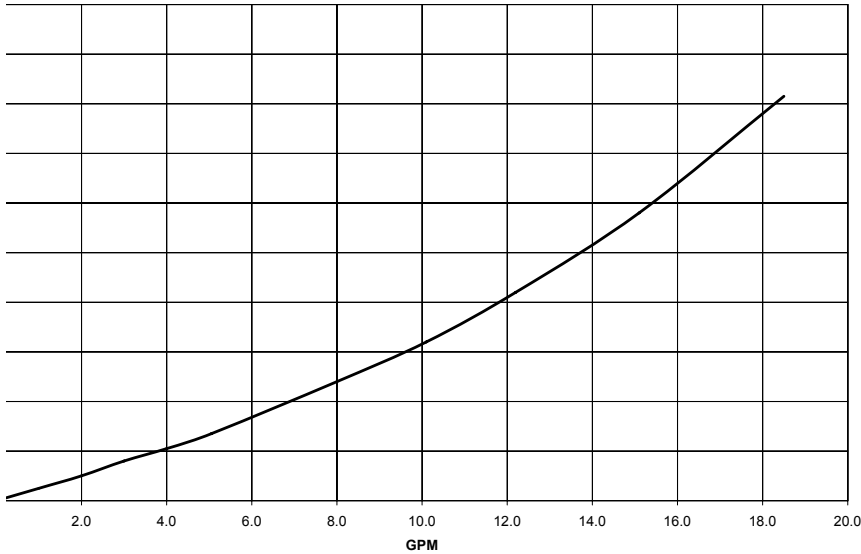

NOTE: Please ensure that the fluid is properly filtered before entering the meter. Foreign particles will cause inaccuracy as well as malfunction of meter.

©2011 Badger Meter, Inc. All rights reserved.



Due to continuous research, product improvements and enhancements, Badger Meter reserves the right to change product or system specifications without notice, except to the extent an outstanding contractual obligation exists.

Badger Meter | P.O. Box 245036, Milwaukee, Wisconsin 53224-9536
800-876-3837 | infocentral@badgermeter.com | www.badgermeter.com