

**Badger®
Series 2200
Batch Controller**

**Bakery Simple On-Line Batching
Process Control**

**Application
Brief**

APPLICATION

Features such as high accuracy, low flow capability, and repeatability make Badger Meter instrumentation the ideal choice for flow control in bakeries or any batching application. Typically, bakeries require batching of ingredients such as water, oil, dyes and sugar solutions.

FEATURES

The Badger Meter Series 2200 Batch Controller is an advanced unit capable of handling complex batching functions. For the simple example shown below, we have the Series 2200 dosing dye to a mixing tank with water. As the water fills the tank, the dye valve is pulsed on and off to reach the correct mixture. In addition, the unit controls the operation of the mixer so as not to burn it out when the tank is empty. When the liquid has filled the tank, the controller opens the outlet valve emptying the tank and begins the process over again.

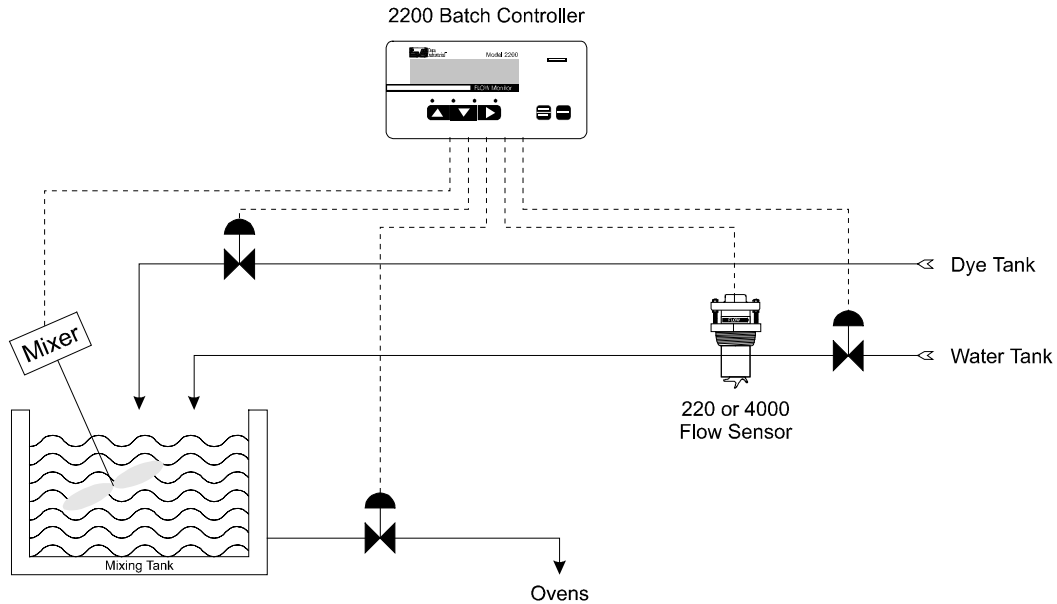

DAB-019-01

Badger® and Data Industrial® are registered trademarks of Badger Meter, Inc.

4-09



Please see our website at www.badgermeter.com
for specific contacts.

Copyright © Badger Meter, Inc. 2009. All rights reserved.

Due to continuous research, product improvements and enhancements, Badger Meter reserves the right to change product or system specifications without notice, except to the extent an outstanding contractual obligation exists.



BadgerMeter, Inc.

6116 E. 15th Street, Tulsa, Oklahoma 74112
(918) 836-8411 / Fax: (918) 832-9962
www.badgermeter.com