

Badger® Series 220 Flow Sensor

Primary/Secondary Chill Water Dual Sensor Method

Application Brief

SYSTEM

A primary/secondary chill water system consists of a primary flow loop containing the chillers and associated pumps, a secondary loop for distribution throughout the facility, and a common bypass section sized to handle the full flow of either. The function of the bypass section is to eliminate the possibility of damage due to freeze-up or over-pressurization of the chiller system, while permitting maximum flow to distribution even when peak loads exceed chiller capacity. Each in-line chiller pump is sized to develop just enough head to compensate for losses in the chiller and associated fittings. Since the pressure differential across the bypass section is essentially zero, the need for pressure-regulating control valves is eliminated. As a result, the flow through each chiller remains constant under all load conditions. Conversely, any surplus flow in the secondary loop also passes through the bypass, but in bypass section, selecting chiller combinations that, as closely as possible, balance supply and load flows as indicated by a zero flow in the bypass.

PROBLEM

Flow instrumentation for the bypass can be expensive and of questionable accuracy. This occurs because the bypass section must be sized to handle the total flow of either the primary or secondary loop with a minimum pressure drop, causing piping to be over-sized for normal operating conditions. As a result, the flow velocity in this section tends to be very low, with direction reversals at times of deficient chill water production. Instrumentation that can provide accurate flow data under these conditions is expensive, difficult to size, and can add considerable head loss at times of peak flow.

SOLUTION

Badger Meter offers a low cost, simple to install, alternative to the traditional control system. Since a primary/secondary system maintains constant chiller flows, even while secondary flows change with cooling demands, the flow through the primary loop becomes essentially a function of the size and number of chillers on line. If our Series 220 sensor is installed in the secondary loop, our set point controller can select the chiller combinations that will maintain the primary loop flow at levels equal to or slightly greater than that of the secondary loop. The bypass section is no longer of importance as a control point, but will carry a slight chiller surplus.

ADVANTAGES

Beyond the obvious reduction in initial sensor and control hardware costs, this approach provides much tighter and easier to understand system control. Further, because the set points can be easily changed in the field, chiller and pump efficiencies can be optimized once in operation. When a computer control system is in use, both chiller and secondary loops can be monitored, with pump selection and control by the computer. This approach provides the tightest control, since in an actual operating system, flow through the chillers is not a constant, but dynamic due to pinch off and other flow interaction in the chill water header. By monitoring both flows, chiller staging can precisely match load demands and chiller performance to maximize efficiency and minimize operating costs. Refer to the diagram below for wiring and system details.

HARDWARE

Sensors are available of both brass and stainless steel construction. Hot tap versions make installation and service possible with fully pressurized active piping systems. Set points are available from at least two Badger Meter products with a variety of options, including digital displays, time delays, hysteresis, and analog outputs. Contact the factory or your local representative for assistance in choosing the hardware combination best suited for your application.

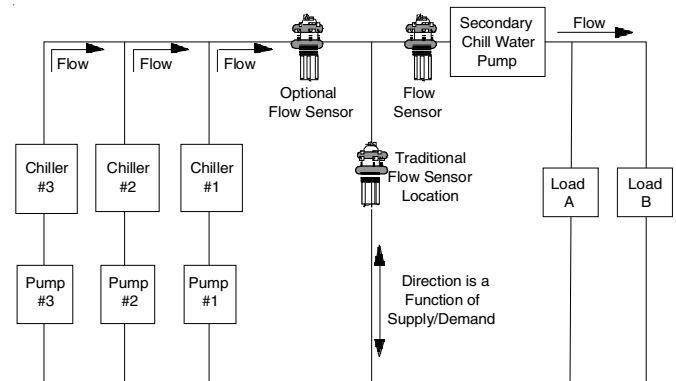

DAB-029-01

Badger® and Data Industrial® are registered trademarks of Badger Meter, Inc.

4-09



Please see our website at www.badgermeter.com
for specific contacts.

Copyright © Badger Meter, Inc. 2009. All rights reserved.



BadgerMeter, Inc.

6116 E. 15th Street, Tulsa, Oklahoma 74112

(918) 836-8411 / Fax: (918) 832-9962

www.badgermeter.com

®

Due to continuous research, product improvements and enhancements, Badger Meter reserves the right to change product or system specifications without notice, except to the extent an outstanding contractual obligation exists.