

Badger Meter Series 200 Hot Tap style liquid flow sensors are designed for use in cases where pipelines will be in continuous service and depressurizing or draining the system for installation or service is not practical.

The Series 200 Hot Tap sensors are designed to be installed either in a depressurized pipe by hand or "Hot Tapped" into a pressurized pipe line. Both installation procedures are listed in this Application Note. If there is the slightest possibility that the pipe could be full or pressurized, FOLLOW THE INSTALLATION FOR PRESSURIZED PIPE.

Refer to the Installation Diagram for location or identification of the various parts described in the following procedures.

The insertion depth and alignment of the sensor assembly are critical to the accuracy of the flow measurement. The Flat End of the sensor tube assembly MUST BE INSTALLED 1-1/2" from the inside wall of the pipe. In order to allow for variations in wall thickness, lining or coatings, the depth adjustment is controlled by the position of the Hex Nuts on the three (3) threaded studs of the Hex Mounting Adapter. The Hex Mounting Adapter is provided with a 2" Male NPT connection. Both Gate and Ball Valve units are provided with 2" nipples for mounting onto saddles, weld-o-lets, etc.

Depth setting is accomplished by positioning the hex nuts 14-7/8" minus the thickness of the pipe, from the Outside Diameter of the Pipe. For example, measure the wall thickness of the pipe from the coupon removed when the 1-7/8" hole was cut into the pipe. If the pipe was 1/8" thick, subtract 1/8" from 14-7/8" or position the nuts 14-3/4" from the outside diameter of the pipe. This will allow the 16-3/8" sensor to protrude 1-1/2" into the pipe.

Apply Anti-Seize thread lubricant, supplied with the sensor, to the threaded studs of the mounting adaptor.

The alignment of the impeller with the flow in the pipe is accomplished by aligning the two (2) "sight holes" at the top of the sensor tube assembly with the center line of the pipe. **Make sure the alignment is made to the pipe and not to a wall or surface near the sensor.** To adjust, loosen the two (2) set screws in the positioning collar with a 3/32" Allen wrench provided in the Series 200 Hot Tap Installation Kit. Slip one end of the 1/4" x 18" steel rod (also supplied in the installation kit) through the holes in the sensor tube. Rotate the sensor tube until the rod is centered on the pipe. Ensure the flow label "Arrow" on the sensor matches the liquid flow direction. Tighten the positioning collar Allen Screws to lock the sensor tube assembly in position. Note: As a backup to the flow direction arrow label on the tube assembly, there is a smaller hole located beside one of the sighting holes in the tube, to also indicate the upstream side of the tube assembly.

I. IF THE PIPE IS DEPRESSURIZED AND DRAINED.

- A. Drill or cut a 1-7/8" hole in the pipe with a drill or hole saw. Note the pipe wall thickness for use in calculating sensor assembly depth. A location on the top of the pipe is best for overall performance and service life; however, any radial location on the top half of the pipe is acceptable. Allow a minimum of ten (10) pipe diameters upstream and five (5) downstream from the sensor of straight unobstructed pipe to allow full development of the flow profile.
- B. Install either a service saddle or welded pipe fitting (2" female NPT) on the outside diameter of the pipe over the 1-7/8" hole.

- C. Install the Badger Meter isolation valve and nipple onto the fitting using pipe thread sealant or teflon tape on all threads.
- D. Install the Badger Meter HEX Mounting Adapter onto the valve assembly. Use pipe thread sealant on the adapter. Tighten the HEX Adapter so that no stud is aligned with the center-line of the pipe. This could interfere with final sensor alignment. Measure depth and set the height of the nuts of the hex mounting adapter.
- E. Open the bleed petcock valve on the HEX adapter to relieve the pressure as the sensor tube is installed. Carefully hand insert the Badger Meter Hot Tap flow sensor tube into the HEX Mounting Adapter. The sleeve should be inserted past the top two "O"-rings in the adapter (approx. 1 - 1-1/4 inches). **Take care not to push the tube in too far as the impeller could be damaged if it strikes the closed valve.**
- F. Even if the sensor is installed with system drained, Badger Meter recommends that a Model 225H, Hot Tap Insertion/Removal Tool be purchased for future service. This tool allows the sensor tube assembly to be removed from the pipe line without draining the entire loop where the sensor is mounted.
- G. In a fully depressurized and drained pipe, the sensor tube assembly may be installed by hand. **Carefully and very slowly** open the isolation valve to relieve any pressure that may have built up. Fully open the isolation valve. Push the sensor tube into the pipe with a slight twisting motion. Guide the sensor collar holes over the three hex adapter studs until the collar rests on the nuts. Hex nuts should have been previously set to the correct height. Install the three (3) lock nuts onto these studs at the top of the positioning collar and securely tighten.
- H. Loosen the two set screws in the positioning collar with a 3/32" Allen wrench. Align the sensor sight holes along the pipe axis using the alignment rod provided in the installation kit supplied with the sensor. Ensure that the flow label arrow on the sensor matches the liquid flow direction inside the pipe. Tighten the positioning collar set screws. Note: As a backup to the flow label arrow, there is a small hole located beside one of the sighting holes to also indicate the upstream side of the sensor. (See "Alignment of Flow Sensor" section of the Series 200 Sensor Manual for further description of this procedure).

II. INSTALLATION INTO A PRESSURIZED PIPE LINE.

- A. Install either a service saddle or welded pipe fitting (2" female NPT) on the outside diameter of the pipe. A location on top of the pipe is best for overall performance and service life; however, any radial location on the top half of the pipe is acceptable. Allow a minimum of ten (10) pipe diameters upstream and five (5) downstream from the sensor of straight unobstructed pipe to allow full development of the flow profile.
- B. Install the Badger Meter isolation valve and nipple onto the fitting using pipe thread sealant or teflon tape on all threads.



- C. Several pipe tapping machines are available with 2" thread connections. Use one equipped with the appropriate 1-7/8" cutter for the pipe material being tapped. To attach the tapping machine to the isolation valve prior to cutting into the pipe, pressure test the valve, nipple and saddle assembly with the valve open. This will ensure that all connections and seals are tight. Note pipe wall thickness for use in calculating sensor depth later.
- D. Slowly open the valve, insert the cutting tool and lower past the valve to the pipe. Drill the 1-7/8" hole according to the manufacturer's directions. Withdraw the cutter past the valve and close valve, remove the cutting tool. Note: The pipe wall thickness of the coupon removed. Use the thickness of this coupon to assist in calculating sensor assembly depth.
- E. Install the Badger Meter HEX Mounting Adapter onto the 2" NPT valve assembly. Use proper pipe thread sealant between the adapter and the valve threads. Tighten the HEX Adapter so that no stud is aligned with the center-line of the pipe. This could interfere with final sensor alignment.
- F. Open the bleed petcock valve on the HEX adapter to relieve the pressure as the sensor tube is installed. Carefully hand insert the Badger Meter Hot Tap flow sensor tube assembly into the HEX Mounting Adapter. The sleeve should be inserted past the top two "O"-rings in the adapter (approx. 1 - 1-1/4 inches). **Take care not to push the tube in too far as the impeller could be damaged if it strikes the closed valve.**
- G. **Badger Meter Model 225H, Hot Tap Insertion/Removal Tool must be used to install or remove a sensor into a pressurized line. Failure to use this tool could result in injury.** The Model 225H Hot Tap provides the mechanical advantage to insert the sensor tube against line pressure and provides a restraint when removing the sensor from a pressurized pipe. To install the Model 225H Hot Tap Tool, first remove the plastic thread protector from the positioning collar of the Sensor Tube assembly. Then remove the slotted thread adapter from the Model 225H insertion tool and screw it into the positioning collar.
- H. Turn the handle of the insertion tool counterclockwise until the thrust shaft collar contacts the tip cross bar of the tool. Attach the base of the insertion tool fully into the groove of the HEX Mounting Adapter. To secure the Model 225H to the HEX Mounting Adapter, tighten the thumb screws

at the base of the tool until they just touch the flats of the HEX Adapter, then back off one turn. Next, guide the sensor cable into the slot of the adapter. Turn the insertion tool handle clockwise until the thrust shaft captive nut contacts the top threads of the slotted thread adapter.

- I. Screw the captive nut onto the slotted thread adapter. Secure the threaded adapter. Tighten the thumbscrews at the insertion tool base against the HEX Adapter.
- J. **Close** the bleed petcock and **slowly open** the isolation valve. Turn the Insertion Tool handle clockwise to insert the sensor tube assembly through the valve. Guide the holes of the sensor collar over the three (3) threaded studs of the HEX Mounting Adapter. Carefully lower the sensor until the Positioning collar contacts the Hex nuts on the threaded studs. Finally install the three (3) lock nuts onto these studs at the top of the positioning collar and securely tighten.
- K. To Remove the Model 225H Insertion/Removal Tool, unscrew the captive nut, loosen knurled screws, and remove the Insertion Tool and slotted adapter. Replace the plastic thread protector to protect threads unless electrical conduit is installed. Reinstall the slotted adapter into Insertion Tool so that it is not misplaced.
- L. Loosen the two set screws in the positioning collar with a 3/32" Allen wrench. Align the sensor sight holes along the pipe axis using the alignment rod provided in the installation kit supplied with the sensor. Ensure that the flow label arrow on the sensor matches the liquid flow direction inside the pipe. Tighten the positioning collar set screws. Note: As a backup to the flow label arrow, there is a small hole located beside one of the sighting holes to also indicate the upstream side of the sensor. (See "Alignment of Flow Sensor" section of the Series 200 Sensor Manual for further description of this procedure).

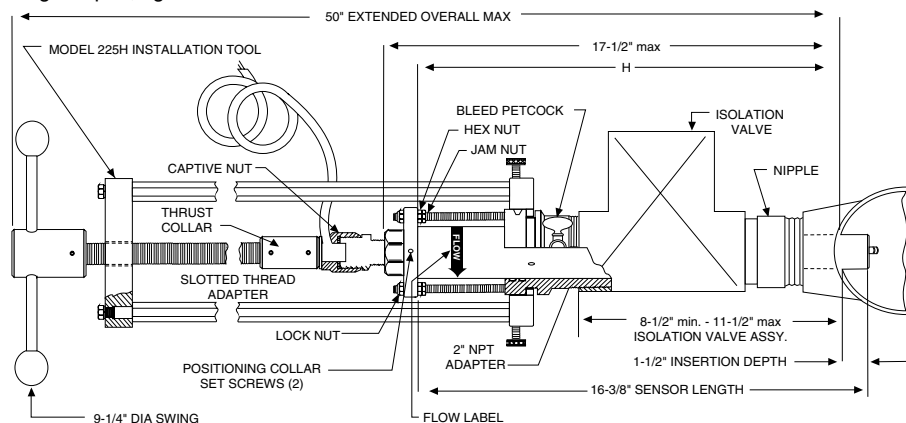

NOTE: ALL DIMENSIONS ARE FOR REFERENCE ONLY.
CUTTING TOOL MAY BE REQUIRE ADDITIONAL CLEARANCE

Badger® and Data Industrial® are registered trademarks of Badger Meter, Inc.



Please see our website at www.badgermeter.com
for specific contacts.

Copyright © Badger Meter, Inc. 2009. All rights reserved.

Due to continuous research, product improvements and enhancements, Badger Meter reserves the right to change product or system specifications without notice, except to the extent an outstanding contractual obligation exists.



BadgerMeter, Inc.

P.O. Box 581390, Tulsa, Oklahoma 74158
(918) 836-8411 / Fax: (918) 832-9962
www.badgermeter.com