

INTRODUCTION

Badger Meter manufactures a variety of impeller type flow sensors that are optimized for given applications. The result is that three fundamentally different sensing methods are used, and the purpose of this technical bulletin is to briefly describe the operating principles and unique characteristics of each approach.

The three sensing techniques and the products associated with each method are:

Sensing Method	Related Sensors
Coupled Transformer	Series 200
Inductive Proximity	Series 4000
AC Generator	Series 1400 Battery-Powered Meters

DESCRIPTION

1) Coupled Transformer Types:

The coupled transformer detection scheme is used primarily in the Badger Meter Series 200 insertion type flow sensors. The primary advantage of this technique in this application are:

- a) Maximum signal to noise performance for this sensor form factor. The use of a separate transmitter and receiver operating at a high frequency results in good signal modulation and rejection of 60 Hz interference.
- b) No measurable torque on the impeller is imposed by the sensing method; the low end performance and turn down ratio is therefore enhanced.
- c) The elimination of substantial magnetic fields prevents the accumulation of ferromagnetic particles, contributing to consistent performance for extended periods in a wide range of applications.

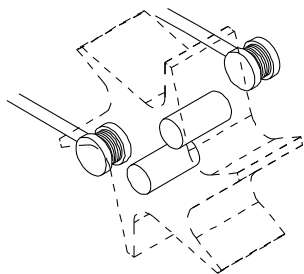

Figure 1

The sensor consists of three basic elements: the transmitter, the receiver, and the ferrite cores (2) embedded in the impeller.

The transmitter consists of a small coil located at the bottom of one of the legs of the molded housing and the associated circuitry required to excite the coil. The receiver employs an identical coil, located in the same position in the opposite leg of the housing. The receiver is tuned to the same frequency as the transmitter, and the output of the receiver is applied to an amplitude modulation detector.

The amplitude of the received signal is modulated (changed) by the relative position of the ferrite cores in the impeller with respect to the fixed coils in the housing. When one of the cores is exactly in line with the transmitter and receiver coils, the received signal is at its maximum strength; conversely, when the cores move out of line with the sensing, amplitude signal is reduced. There are two cores located 180° apart in the impeller, and this modulation completes two full cycles (pulses) per revolution of the impeller. The remaining electronics function to amplify the signal and produce a clean digital square wave signal at the sensor output.

One of the unique features of this sensor type is that there is only a two wire connection, and both signal and power are shared on this wire pair. Power is supplied to the sensor from a current limited source (typically a resistor to a voltage source providing at least 1 mA to operate the circuitry). When rotation is sensed by the detector, the output voltage is briefly switched **low** twice per revolution, which can then be sensed by the external display or other device.

2) Inductive Proximity Types:

The inductive proximity detection scheme is used primarily in the Badger Meter plastic in-line type flow sensor, the Badger Series 4000. This sensing method provides similar advantages in this application as listed for the insertion types above with some additional benefits:

- a) The electronic package can be serviced or replaced without interrupting the integrity of the piping system.
- b) The sensing “target” in the impeller is low in mass, and thus allows the impeller assembly to be as low in mass as possible. This results in low starting torque and outstanding performance at low flow rates.



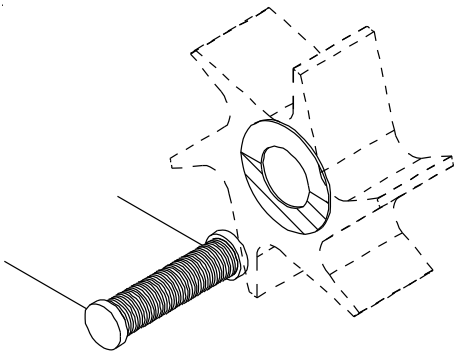

Figure 2

The sensor contains three basic function sections: the oscillator, the detector, and the conductive target embedded in the impeller.

The oscillator circuit includes the coil, which is external to the printed circuit board. Some amplitude control circuits compensate the oscillator to the environment, so that the sensitivity or threshold adjustments are not required. The target is a small doughnut-shaped printed circuit board that is manufactured to have a conductor on 180° of its surface.

The oscillator circuit produces an external AC or electromagnetic field that is directed toward the impeller. When this field intercepts a conductor, some energy is lost in this conductor (“eddy-current” losses), and the result is that the oscillator amplitude is reduced. When fluid turns the impeller, the target inside moves alternately in and out of the field; the oscillator amplitude is therefore modulated by the impeller rotation.

The detector amplifies the modulated signal and produces a clean, digital square wave output. As the target is conductive on half of its surface, one output pulse is produced per revolution of the impeller.

These sensors use a three wire connection, i.e. sensor power, power/signal common, and sensor output. The sensor output has been designed to be very flexible, and is compatible with most logic inputs without the use of external components.

3) AC Generator Types:

The AC generator detection method is used only with the Badger Meter Series 1400 battery-powered flow meters. This approach sacrifices the general benefits discussed for the coupled transformer and proximity type detectors for the primary purpose of minimizing the total system power requirements.

The sensor is comprised of two fundamental pieces: the magnet embedded in the impeller and the coil assembly in the sensor housing. The coil assembly consists of many turns of fine wire around a soft iron core positioned in close proximity to the impeller. When the impeller rotates, the four pole magnet produces a changing magnetic field, which passes through the coil and thus produces an AC output voltage.

The amplitude and frequency of the resultant output voltage is proportional to the rate of rotation. As the magnet is poled alternately N-S-N-S, two cycles are completed per revolution of the impeller. The low power detection circuitry in the compatible Badger Meter electronics amplify this signal to drive the display device.

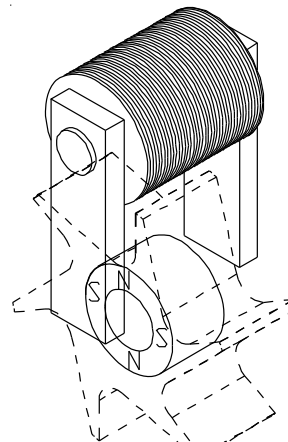

Figure 3

Badger® and Data Industrial® is a registered trademark of Badger Meter, Inc.



Please see our website at www.badgermeter.com for specific contacts.

Copyright © Badger Meter, Inc. 2009. All rights reserved.

Due to continuous research, product improvements and enhancements, Badger Meter reserves the right to change product or system specifications without notice, except to the extent an outstanding contractual obligation exists.



BadgerMeter, Inc.

P.O. Box 581390, Tulsa, Oklahoma 74158
(918) 836-8411 / Fax: (918) 832-9962
www.badgermeter.com