

The purpose of this Technical Brief is to explain the method used by Badger Meter to determine the calibration constants published in its literature.

All published K Factors and Offsets published by Badger Meter are based on actual NIST traceable testing performed either at our own flow laboratory or at Alden Research Laboratories. Both laboratories calibrate using the gravimetric method as prescribed by ASME / ANSI MFC-9M standard, *Measurement of Liquid Flow in Closed Conduits by Weighing Method*. Both of these laboratories use water as the medium, and calibrate by weighing the fluid flowed during a precisely controlled time interval accurate to ± 1 millisecond. Weighing accuracy is $\pm 0.02\%$ or better. During the collection period, the output pulse train from the meter under test is counted with an accuracy of ± 1 pulse. This count is converted to a frequency value accurate to $\pm 0.015\%$ or better. The volume collected over the controlled time interval is converted into a flow rate (GPM) accurate to $\pm 0.025\%$.

This procedure is repeated at least 12 times for a given sensor over a range from approximately 2% less than minimum rated flow to approximately 1% greater than maximum. At least six (6) different samples of actual production sensors are tested sequentially, and analyzed individually by linear regression techniques. The entire family of tested sensors, a minimum of 72 points roughly equally distributed across the full rated flow range, is separately analyzed by linear regression techniques to determine the published values of K Factor and Offset for a specific pipe size. Note that the weight data as gathered is adjusted for variations in density with temperature and the buoyancy of the ambient air in the conversion to volume. The combined uncertainty of the input data is found by adding, in quadrature, the uncertainties listed above or $\pm 0.03\%$. Sensor calibration accuracy as specified in Badger Meter literature is determined by the variation from sensor to sensor evidenced in the multi sensor calibration.

Badger Meter standard practice in installing a sensor in the calibration line uses a flow straightener connected to a straight pipe run of at least 10 pipe diameters upstream of the sensor, and a minimum straight run of 5 pipe diameters downstream. Careful attention is given to ensure that all installation parameters conform to published specifications. This is particularly important with insert style sensors, where installation depth and sensor angular orientation are strictly maintained.

It is the practice at Badger Meter to calibrate specific sensors only on special order. The intensive calibration activities at Badger Meter bear up the fact that the specified accuracies are met by the shipped product. Custom calibration of sensors over a specified flow range less broad than the published range for a given product can produce tighter tolerances on measured flow rate. This advantage must be weighed in the light of the variability introduced in sensor response by the installation variability. When custom calibrations are required the best results occur when the calibration rig replicates actual flow piping geometry.

On-site calibration is not normally required by most of our user base. In those rare instances where contractual or other requirements demand such a calibration, it is recommended that the user calibrate the sensor to his own master flowmeter. Most Badger Meter sensor readouts can be used to determine the proper K Factor and Offset values for a given sensor in a specific installation. In these rare applications, consult Badger Meter on the recommended technique.

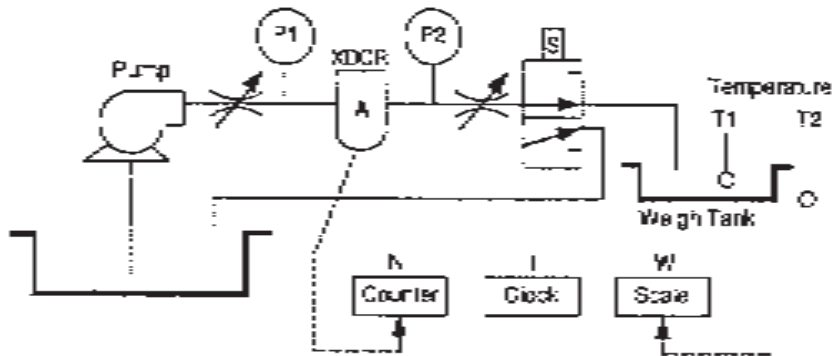

DTB-049-01

Badger® and Data Industrial® are registered trademarks of Badger Meter, Inc.

4-09



Please see our website at www.badgermeter.com
for specific contacts.

Copyright © Badger Meter, Inc. 2009. All rights reserved.

Due to continuous research, product improvements and enhancements, Badger Meter reserves the right to change product or system specifications without notice, except to the extent an outstanding contractual obligation exists.



BadgerMeter, Inc.

P.O. Box 581390, Tulsa, Oklahoma 74158
(918) 836-8411 / Fax: (918) 832-9962
www.badgermeter.com