

The A-1018-4026 is an isolating device permitting a Badger Meter 200 series flow sensor to provide an output signal to more than one device. One such example would be the sharing of the flow signal between a pump station control panel and an irrigation control system like the Toro Network 8000.

In this example, the pump control logic must be isolated from any other connection to work properly. If the Network 8000 were connected directly to the sensor, the pump control would not work.

The A-1018-4026 remedies this problem by optically isolating the output of the sensor. The sensor leads are connected to the sensor input terminals Red to #7 and Black to #6) in parallel with the primary device (the pump control panel). The A-1018-4026 requires power. A 12-28 VDC power supply must be connected to the power input terminals (1 and 2). Then terminals #3 and #4 become the isolated sensor terminals for the secondary device (The Network 8000). Be careful to observe polarity with all connections.

In the A-1018-4026, signal output isolation is achieved by using a small amount of the signal to power the output stage. From a signal standpoint, in most applications the only difference between the two versions is that the Signal Out (-) wire is connected to Pin #1 in the A-1018; and Pin#4 in the A-1018-4026. For almost any application where the A-1018 is acceptable, the versions can be made interchangeable by connecting Pin#1 to Pin#4.

Mechanical

The A-1018-4026 installs into a standard Octal Relay Socket (not provided).
One example of this type socket would be a POTTER-BRUMFIELD # 27E122.

Electrical Specs:

Power Supply:

12-28VDC @ 65mA

Sensor Power Out (Pin#5 Ref to Pin#6):

14VDC @ 15mA Max.

Sensor Input Threshold Voltage:

$V_{Low} = 2.0VDC$

$V_{High} = 6.0VDC$

Signal Out (Pin#3):

Open Collector Current Sink:

30mA Max .

Maximum applied Open Circuit Voltage:

28VDC

Leakage Current ($V_{High-State}$):

80uA @8VDC

(100K OHMS Signal (+) to Signal(-) after initial 10uF capacitor charge)

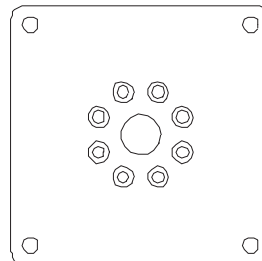
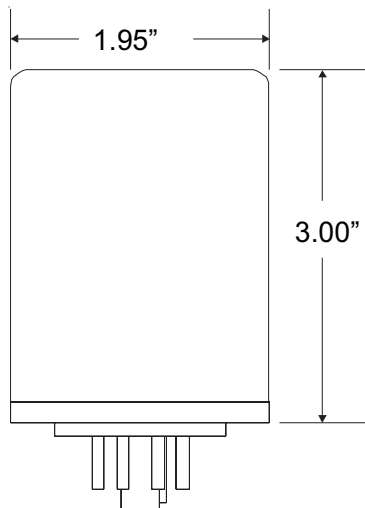

PIN	DESC	CONNECTIONS
1	COMMON	POWER COMMON & CABLE SHLD
2	POWER IN	+ PWR INPUT / 12 -24 VDC
3	SIGNAL OUT(+)	OPEN COLLECTOR TRANSISTOR OUTPUT (REQUIRES PULL-UP TO LOGIC LEVEL)
4	SIGNAL OUT(-)	
5	SENSOR POWER	220 SERIES UNUSED
6	SENSOR COMMON	BLACK & DRAIN
7	SENSOR SIGNAL	RED
8	NOT USED	

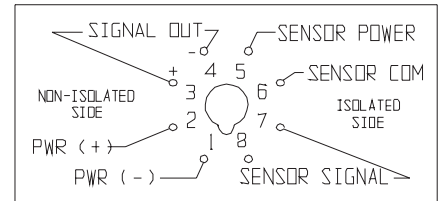

**Data
Industrial**

SENSOR OPTICAL ISOLATOR
MODEL No. A-1018-4026



Adding a Toro Network 8000 Irrigation Control System to an existing analog transmitter where all power supplies and sensor signals must be isolated from each other

Note: The Model A-1018-4026 must be used in this application due to the isolation requirements of TORO and the loop-powered transmitter.

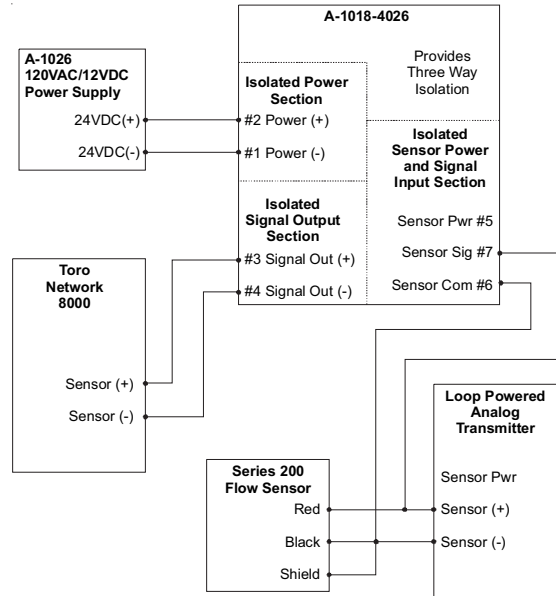

Adding a Toro Network 8000 Irrigation Control System to an existing Model 330. Power supplies and sensor signals must be isolated from each other

Note: The Model A-1018-4026 must be used in this application due to the isolation requirements of TORO and the loop-powered transmitter.

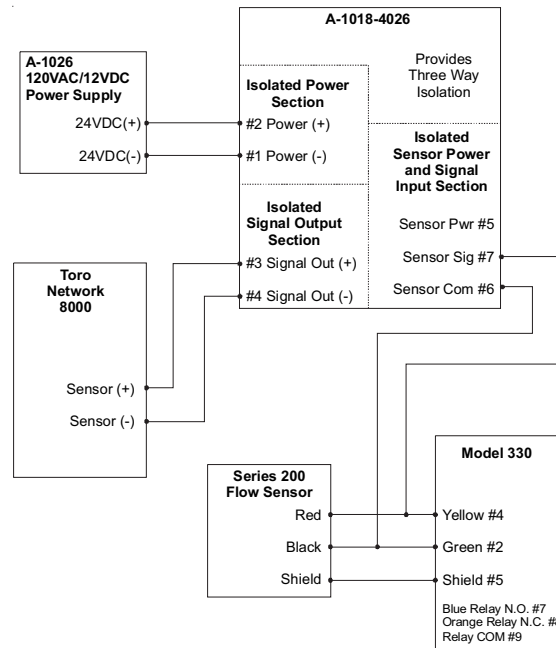

Due to continuous research, product improvements and enhancements, Badger Meter reserves the right to change product or system specifications without notice, except to the extent an outstanding contractual obligation exists.



Please see our website at www.dataindustrial.com for specific contacts.

Copyright © Badger Meter, Inc. 2005. All rights reserved.



BadgerMeter, Inc.

6 County Road, Unit #6 Rear
Mattapoisett, MA 02739-0740
Telephone: (508) 758-6390 Fax: (508) 758-4057
www.dataindustrial.com