

Data Industrial Series 200 Hot Tap style liquid flow sensors are designed for use in cases where pipelines will be in continuous service and depressurizing or draining the system for installation or service is not practical.

Series 200 Hot Tap sensors are designed to be installed either in a depressurized pipe by hand or “Hot Tapped” into a pressurized pipeline. Both installation procedures are listed in this Application Note. If there is the slightest possibility that the pipe could be full or pressurized, FOLLOW THE INSTALLATION FOR PRESSURIZED PIPE.

Refer to Figure 1 for location or identification of the various parts described in the following procedures.

The insertion depth and alignment of the sensor assembly are critical to the accuracy of the flow measurement. The Flat End of the sensor tube assembly **MUST BE INSTALLED 1-1/2" from the inside wall of the pipe**. In order to allow for variations in wall thickness, lining or coatings, the depth adjustment is controlled by the position of the Hex Nuts on the three (3) threaded studs of the Hex Mounting Adapter. The Hex Mounting Adapter is provided with a 2" Male NPT connection. Both Gate and Ball Valve units are provided with 2" nipples for mounting onto saddles, weld-o-lets, etc.

Depth setting is accomplished by positioning the hex nuts 14-7/8", minus the thickness of the pipe, from the Outside Diameter of the Pipe. For example, measure the wall thickness of the pipe from the coupon removed when the 1-7/8" hole was cut into the pipe. If the pipe was 1/8" thick, subtract 1/8" from 14-7/8" or position the nuts 14-3/4" from the outside diameter of the pipe. This will allow the 16-3/8" sensor to protrude 1-1/2" into the pipe.

Apply Anti-Seize thread lubricant, supplied with the sensor, to the threaded studs of the mounting adaptor.

The alignment of the impeller with the flow in the pipe is accomplished by aligning the two (2) “sight holes” at the top of the sensor tube assembly with the center line of the pipe.

Make sure the alignment is made to the pipe and not to a wall or surface near the sensor. To adjust, loosen the two (2) set screws in the positioning collar with a 3/32" Allen wrench provided in the Series 200 Hot Tap Installation Kit. Slip one end of the 1/4" x 12" steel rod (also supplied in the installation kit) through the holes

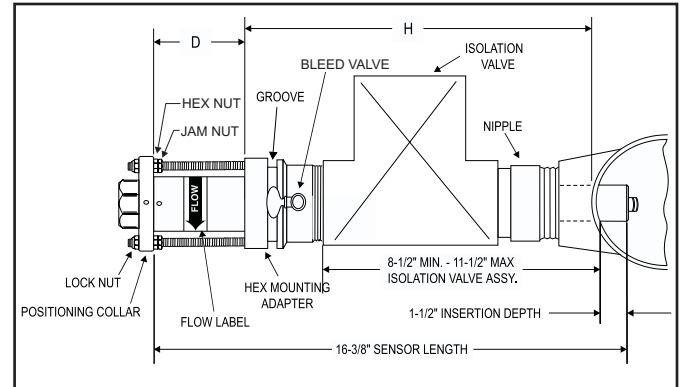

in the sensor tube. Rotate the sensor tube until the rod is centered on the pipe. Ensure the flow label “Arrow” on the sensor matches the liquid flow direction. Tighten the positioning collar Allen Screws to lock the sensor tube assembly in position. Note: As a backup to the flow direction arrow label on the tube assembly, there is a smaller hole located beside one of the sighting holes in the tube, to also indicate the upstream side of the tube assembly.

If the pipe is depressurized and drained

- 1) Drill or cut a 1-7/8" hole in the pipe with a drill or hole saw. Note the pipe wall thickness for use in calculating sensor assembly depth. A location on the top of the pipe is best for overall performance and service life; however, any radial location on the top half of the pipe is acceptable. Allow a minimum of ten (10) pipe diameters upstream and five (5) downstream from the sensor of straight unobstructed pipe to allow full development of the flow profile.

- 2) Install either a service saddle or welded pipe fitting (2" female NPT) on the outside diameter of the pipe over the 1-7/8" hole.

- 3) Install the Data Industrial isolation valve and nipple onto the fitting using pipe thread sealant or teflon tape on all threads.

- 4) Install the Data Industrial Hex Mounting Adapter onto the valve assembly. Use pipe thread sealant on the adapter. Tighten the Hex Adapter so that no stud is aligned with the center-line of the pipe. This could interfere with final sensor alignment. Measure depth and set the height of the nuts of the hex mounting adapter.



5) Open the bleed petcock valve on the Hex Adapter to relieve the pressure as the sensor tube is installed. Carefully hand insert the Data Industrial Hot Tap Flow Sensor tube into the Hex Mounting Adapter. The sleeve should be inserted past the top two "O"-rings in the adapter (approx. 1 - 1-1/4 inches). Take care not to push the tube in too far as the impeller could be damaged if it strikes the closed valve.

6) Even if the sensor is installed with the system drained, Data Industrial recommends that a HTT, Hot Tap Insertion/Removal Tool be purchased for future service. This tool allows the sensor tube assembly to be removed from the pipe line without draining the entire loop where the sensor is mounted.

7) In a fully depressurized and drained pipe, the sensor tube assembly may be installed by hand. Carefully and very slowly open the isolation valve to relieve any pressure that may have built up. Fully open the isolation valve. Push the sensor tube into the pipe with a slight twisting motion. Guide the sensor collar holes over the three hex adapter studs until the collar rests on the nuts. Hex nuts should have been previously set to the correct height. Install the three (3) lock nuts onto these studs at the top of the positioning collar and securely tighten.

8) Loosen the two set screws in the positioning collar with a 3/32" Allen wrench. Align the sensor sight holes along the pipe axis using the alignment rod provided in the installation kit supplied with the sensor. Ensure that the flow label arrow on the sensor matches the liquid flow direction inside the pipe. Tighten the positioning collar set screws. Note: As a backup to the flow label arrow, there is a small hole located beside one of the sighting holes to also indicate the upstream side of the sensor.

Installation into a pressurized pipeline using Model HTT.

For information on installing hot tap sensor with older 225H consult Technical Bulletin #41

For pipe sizes 3" and above; all Data Industrial sensors are inserted 1 1/2" from the inside wall of the pipe. The insertion depth is controlled by the position of the hex nuts on the three threaded rods. The formula below defines the distance between the top of the sensor hex mounting adaptor and the bottom of the positioning collar (the top of the hex nut). Reference Figure 3.

$$D = 16 \frac{3}{8} - (H + \text{Pipe Wall Thickness} + 1.5 \text{ " })$$

Example: If sensor is installed in a 8"Sch 80 pipe with a pipe wall thickness of .5" and the "H" dimension is 0" then the calculation would be as below:

$$D = 16 \frac{3}{8} - (10" + 0.5" + 1.5")$$

$$D = 4 \frac{3}{8}"$$

1. Set one set of hex/jam nuts so that the distance between the top surface of the hex nut and the top surface of the Hex Mounting Adaptor is equal to the "D" dimension calculated above. Then adjust the other two sets of hex/jam nuts 1/2" below the first jam nut to allow clearance for the tool top yoke.

2. Remove the split ring and clevis pin and slide tool bottom yoke into the groove on the sensor Hex Mounting Adaptor and secure by replacing the clevis pin and split ring.

3. Mark sleeve 2 3/4" from impeller end of metal sleeve. This mark is a stopping point to insure that impeller/bearing is not damaged. Open the bleed petcock valve on the Hex Adapter to relieve the pressure resulting from the sensor tube insertion. Carefully hand insert the Data Industrial Hot Tap Flow Sensor Sleeve Assembly into the Hex Mounting Adapter until the mark lines up with the top of the Hex Mounting Adapter. At this point the sleeve will have been inserted past the top two "O"-rings in the adapter (approx. 1 - 1-1/4 inches). Take care not to push the sensor past the mark on the sleeve as the impeller could be damaged if it strikes the closed valve.

4. Fully extend tool by turning drive nut counterclockwise with a 15/16" socket or box wrench (not provided) until drive nut contacts tool and slide the Positioning Collar into the tool top yoke.

5. Rotate tool so the threaded rod with the adjusted hex/jam nuts is centered in the top yoke of Hot Tap Tool.

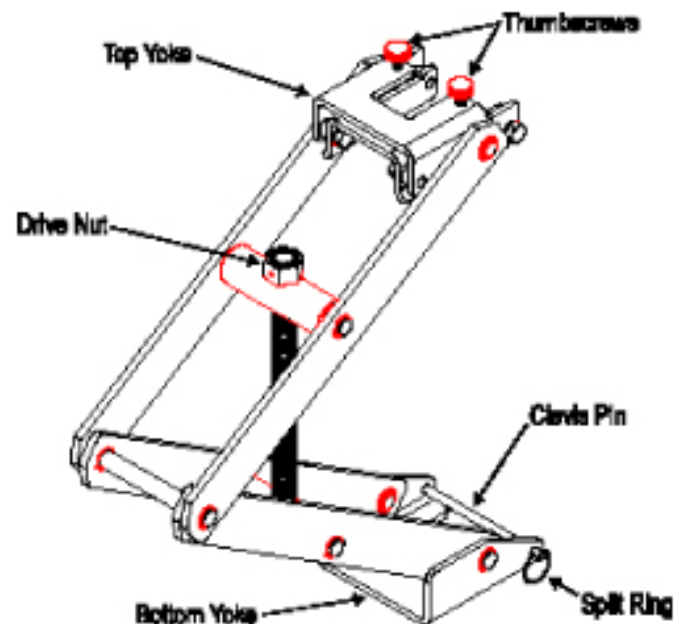

6. Rotate sensor sleeve so positioning collar holes align with the threaded rods and flow direction label is in general direction making sure the positioning collar is located in the recessed area of the top yoke. Slide the top yoke of the tool over the Positioning Collar and secure by tightening the two thumbscrews on the top of the yoke.
7. Close the bleed petcock and slowly open the isolation valve. Slowly turn the 15/16" drive nut clockwise to insert the sensor tube assembly through the valve and into the pipeline. Carefully guide the three (3) threaded studs of the Hex Mounting Adapter through the holes of the sensor positioning collar. Carefully lower the sensor until the Positioning Collar contacts the hex nut preset for the correct depth adjustment. Install the three (3) lock nuts onto the threaded rods, tightening only the lock nut on the threaded rod with the preset hex/jam nut; then, bring the two remaining lock nuts down until they just contact the Positioning Collar. Do not tighten at this time
8. Remove the Model HTT Insertion/Removal Tool, by loosening the two thumbscrews, removing the clevis pin and then sliding the insertion tool off the sensor. Then bring the two remaining sets of hex/jam nuts up to the underside of the positioning collar, and tighten.
9. Align the sensor by first loosening the two set screws in the side of positioning collar with a 3/32" Allen wrench, Then align the sensor sight holes along the pipe axis using the alignment rod provided in the sensor installation kit. Ensure that the flow label arrow on the sensor matches the liquid flow direction inside the pipe. Tighten the positioning collar set screws. Note: As a backup to the flow label arrow, there is a small hole located beside the sight hole on the upstream side of the sensor.



Please see our website at www.badgermeter.com
for specific contacts.

Copyright © Badger Meter, Inc. 2009. All rights reserved.

Due to continuous research, product improvements and enhancements, Badger Meter reserves the right to change product or system specifications without notice, except to the extent an outstanding contractual obligation exists.



BadgerMeter, Inc.

6116 E. 15th Street, Tulsa, Oklahoma 74112
(918) 836-8411 / Fax: (918) 832-9962

www.badgermeter.com