

# Badger® Series 330

Set-Point Relay Control -  
Helps Stop Wasting Water

# Application Brief

A common problem of irrigation systems along freeways, roadsides, and parking lots is the loss of thousands of gallons of water through broken sprinklers. Often these problems are not discovered until plants are lost or complaints are received about overflow.

Badger Meter's Series 330 Relay Control takes care of this problem.

Used with a Badger Meter flow sensor, the Series 330 is a compact, programmable relay controller capable of monitoring the flow rate to a zone of sprinklers. If it detects a greater than normal flow, it's relay will toggle opening a N.C. contact and closing a N.C. contact. These contacts can be used to close the zone valve, master valve, or sprinkler controller, and keep it closed until reset by the operator. A time delay can be set to prevent nuisance shutdowns while the system is charging and higher than normal flows can be expected.

The microcontroller digital circuitry of the Series 330 is programmed from a Windows® based computer program, using a programming kit which includes a cable and software. With a personal computer one can easily program any number of units in the field. Non-volatile memory in the Model 330 saves programmed values indefinitely.

The Series 330 is available with a waterproof box for mounting in a controller, pedestal enclosure or anywhere there is 24VAC power available.

If you're tired of wasting water or worried about a liability, install the Series 330 Relay Control in conjunction with a Badger Meter flow sensor.

The following is an example of typical wiring.

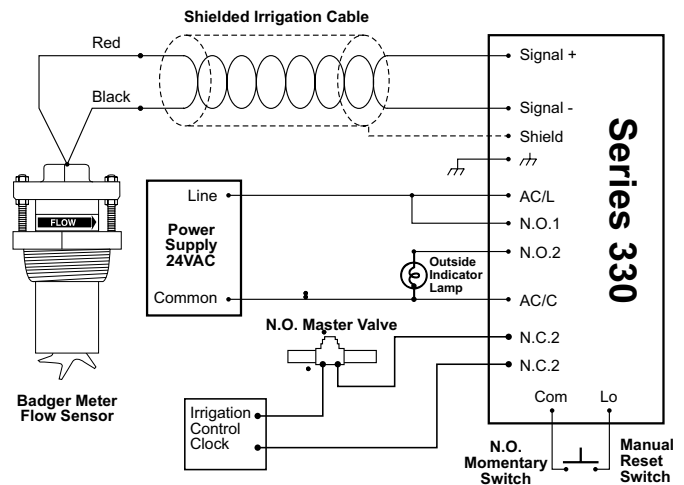

One nice feature of the Series 330 is that with a laptop computer, it is possible to actually watch the relay work. The main, parameter, and status screens are shown below.

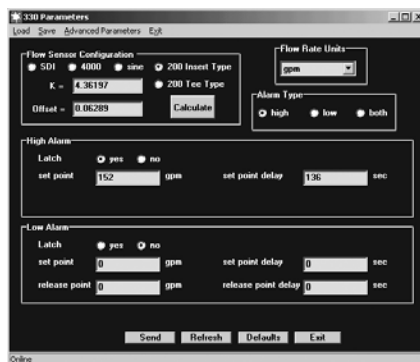
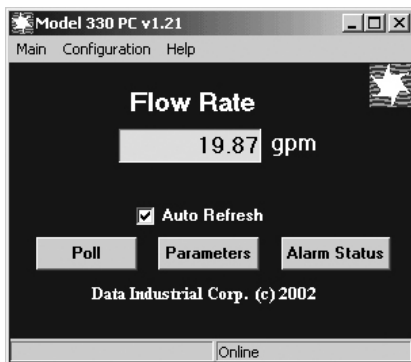

Badger® and Data Industrial® are registered trademarks of Badger Meter, Inc. Windows® is a registered trademark of Microsoft Corporation.

DAB-015-01

4-09



Please see our website at [www.badgermeter.com](http://www.badgermeter.com) for specific contacts.

Copyright © Badger Meter, Inc. 2009. All rights reserved.



**BadgerMeter, Inc.**

6116 E. 15th Street, Tulsa, Oklahoma 74112  
(918) 836-8411 / Fax: (918) 832-9962  
[www.badgermeter.com](http://www.badgermeter.com)