

In film processing, the precise flow rate and volume of the photographic solution is required. By combining the appropriate Data Industrial flow sensor with the Model 320-00, high accuracy and repeatability is attained. This particular system provides a proportional pulse output signal that is computer compatible. The computer in turn maintains the desired flow rate by controlling an electronically actuated ball valve. As the flow increases above the desired rate, the control valve opening decreases, alternately increasing and decreasing. The Model 320-00 facilitates scheduled maintenance procedures.

Should a 4-20mA signal be necessary, a Model 310 can also be easily interfaced to this system without any disruption of service or sacrifice to accuracy.

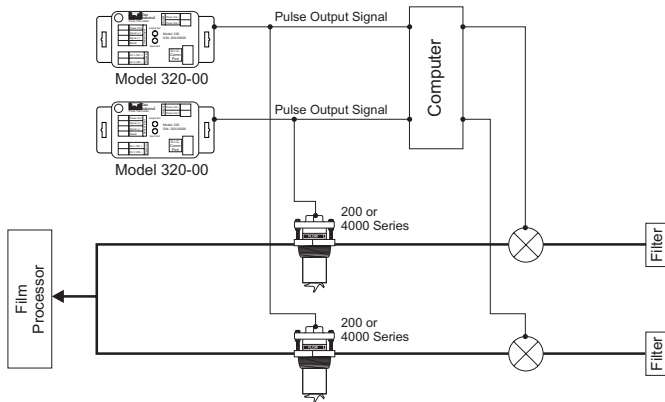

DAB-060-01

1-09



Please see our website at www.badgermeter.com for specific contacts.

Copyright © Badger Meter, Inc. 2009. All rights reserved.

Due to continuous research, product improvements and enhancements, Badger Meter reserves the right to change product or system specifications without notice, except to the extent an outstanding contractual obligation exists.



BadgerMeter, Inc.

6116 E. 15th Street, Tulsa, Oklahoma 74112
(918) 836-8411 / Fax: (918) 832-9962
www.badgermeter.com

