

The Badger® Series 250 flow sensor features a six bladed impeller design with a proprietary non magnetic sensing mechanism, mounted in a cast bronze housing with female NPT threads.

The unique impeller design is less prone to be fouled by water borne debris. The forward curved shape coupled with the absence of magnetic drag provides improved operation and repeatability even at lower flow rates. This is especially true where the impeller is exposed to metallic or rust particles found in steel or iron pipes. As the liquid flow turns the impeller, a low impedance square wave signal is transmitted with a frequency proportional to the flow rate. The signal can travel up to 2000 feet between the flow sensor and the receiving unit without the need for amplification. All sensors except irrigation versions are supplied with 20 feet of 2-conductor 20 AWG shielded U.L. type PTLC 105°C cable and meet CE standards for noise immunity and susceptibility.



STYLE	Example: 2 50 BR 15 0 5 - 0 2 1 1
Cast Bronze Tee (0.5" to 1.5" only)	50
MATERIAL	
Brass/Bronze	BR
SIZE	
0.5"	05
0.75"	07
1"	10
1.25"	12
1.5"	15
ELECTRONICS HOUSING	
PPS	0
ELECTRONICS	
Magnetic	2
FM/CSA Approved	4
Standard	5
IR-Irrigation	6
O-RING	
Viton®	0
EPDM	1
Buna N	8
SHAFT	
Zirconia Ceramic	0
Hastalloy® C	1
Tungsten Carbide	2
Titanium	3
Monel®	5
316 Stainless Steel	6
Tantalum	7
IMPELLER	
Nylon	1
Tefzel®	2
BEARING	
Pennlon®	1
Tefzel	2
Teflon®	3

**250 Series Metal Tee Sensors Ordering Matrix (½" to 1½")
(See 228 Series for pipe sizes 2" to 2½")**

FEATURES

- Sensor electronics easily removed from tee.
- Impeller, bearing, and shaft are easily replaced in field without changing calibration.
- Two wire sensor. Power and signal transmit on single pair of wires up to the distance of 2000 feet.
- Digital signal easily interfaced with transmitters, monitors, or PLC's.

APPLICATIONS

- Energy management and building management systems
- Btu sub-metering systems
- Cooling tower treatment systems
- Condensate return lines



Wetted Materials

- See Ordering Matrix

Tee for 250B

- Cast valve bronze, UNS C83600

Maximum Temperature

- Standard Electronics - 221°F (105°C)
- Irrigation Electronics - 150°F (66°C)

Maximum Pressure

	At 100°F
250BR	400 psi

Recommended Design Flow Range

- 0.3 to 15 ft/sec for 250B

Accuracy

- ± 1.0% of rate

Repeatability

- ± 0.7% over recommended design flow range

Linearity

- ± 0.7% over recommended design flow range

Rangeability

- 60:1

Transducer Excitation

- Quiescent current 600uA @ 8VDC to 35VDC max.
- Quiescent voltage (V_{high})
Supply Voltage $-(600uA * \text{Supply impedance})$
- ON State (V_{Low}) Max. 1.2VDC @ 40mA current limit (15W+0.7VDC)

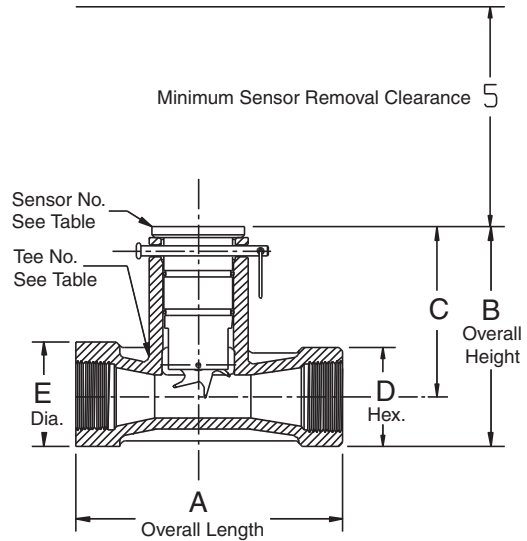
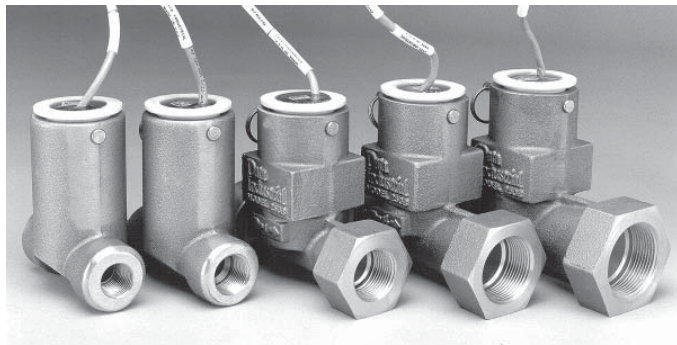

Series No. Complete	Sensor No. See Matrix	Tee No.	NPT	A	B	C	D	E
250B-0.5	See Matrix	813168T	1/2 - 14	4.00	4.67	3.61	N/A	1.63
250B-0.75	See Matrix	813169T	3/4 - 14	4.00	4.67	3.61	N/A	1.63
250B-1.0	See Matrix	81940T	1.00 - 11.5	5.45	4.75	3.75	2.00	2.12
250B-1.25	See Matrix	81941T	1.25 - 11.5	6.06	5.00	3.88	2.25	2.38
250B-1.5	See Matrix	811193T	1.50 - 11.5	6.50	5.19	3.94	2.50	2.62

Electrical Cable for Standard Sensor Electronics

- 20 feet of 2-conductor AWG 20 with AWG 22 drain wire shielded U.L. type PTLC wire provided for connection to display or transmitter unit. Rated to 105°C. May be extended to a maximum of 2000 feet with similar cable and insulation appropriate for application.

Electrical Cable for IR Sensor Electronics

- 48 inches of U.L. Style 116666 copper solid AWG 18 wire with direct burial insulation. Rated to 105°C.

Badger® and Data Industrial® is a registered trademark of Badger Meter, Inc.
 Pennlon® is a registered trademark of Dixon Corporation.
 Hastalloy® is a registered trademark of The Haynes Stellite Company.
 Monel® is a registered trademark of Inco Alloys International, Inc.
 Teflon®, Tefzel® and Viton® are registered trademarks of DePont Dow Elastomers.



Please see our website at www.badgermeter.com
 for specific contacts.

Copyright © Badger Meter, Inc. 2009. All rights reserved.

Due to continuous research, product improvements and enhancements, Badger Meter reserves the right to change product or system specifications without notice, except to the extent an outstanding contractual obligation exists.



BadgerMeter, Inc.

P.O. Box 581390, Tulsa, Oklahoma 74158
 (918) 836-8411 / Fax: (918) 832-9962
www.badgermeter.com