



Badger Meter

Series 200 Insertion Flow Sensor

The Data Industrial® Series 200 flow sensors by Badger Meter feature a six bladed impeller design with a proprietary non-magnetic sensing mechanism. The forward swept impeller shape provides higher, more consistent torque and is less prone to be fouled by water borne debris. The forward curved shape coupled with the absence of magnetic drag provides improved operation and repeatability at lower flow rates. This is especially true where the impeller is exposed to metallic or rust particles found in steel or iron pipes. As the liquid flow turns the impeller, a low impedance square wave signal is transmitted with a frequency proportional to the flow rate. The signal can travel up to 2000 feet between the flow sensor and the display unit without the need for amplification. All sensors except irrigation versions are supplied with 20 feet of Belden type 9320 two conductor shielded cable.

MODEL 220BR (BRASS) AND 220SS (STAINLESS STEEL) SENSOR

The 220BR and 220SS sensors are used in most general flow measuring applications in metallic or non-metallic pipes. The sensor mounts in a 2 inches NPT pipe saddle or Threadolet® for installation in pipe sizes from 3 inches to over 40 inches. Positioning nuts on the three threaded retaining rods allow the sensor to be accurately positioned to a standard insertion depth of 1½ inches into the pipe. When this insertion depth is maintained, and there is at least 10 upstream and 5 downstream diameters of straight uninterrupted flow, an accuracy of +/-1 percent of full scale can be obtained from flow velocities of 0.5 to 30 feet/second (± 4.0 percent of reading within calibration range).



Model 220PVS

The Badger Meter 220PVS flow sensor is an insertion style flow sensor with all wetted parts constructed of non-metallic materials. These sensors are designed for service in corrosive liquids. The metallic trim, in non-wetted areas, is 316 stainless steel. The sensor mounts in a 2 inches NPT thread and may be attached to the pipe with a saddle or other types of mounting hardware.

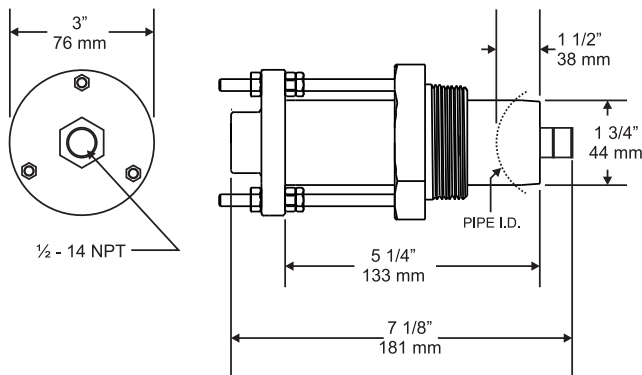

Dimensions Model 220BR, 220SS

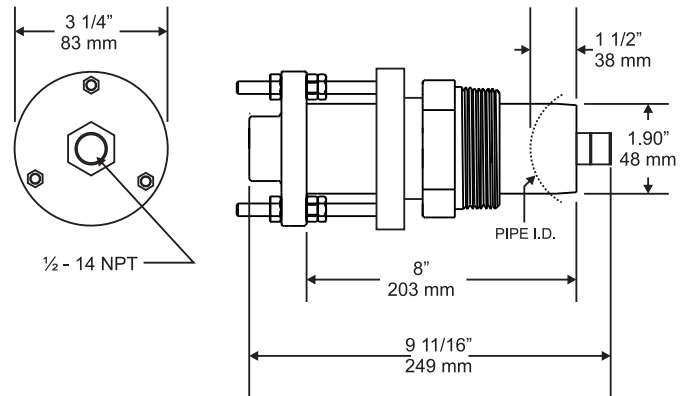

Dimensions Model 220PVS



SPECIFICATIONS

Wetted Materials for all Sensors

- (See ordering matrix)

Sensor Sleeve and Hex Adapter for 220BR

- Sleeve: Admiralty Brass, UNS C44300;
Hex Adapter: Valve Bronze, UNS C83600

Sensor Sleeve and Hex Adapter for 220SS

- 316 Series Stainless Steel

Temperature Ratings

- Standard Version:
22° F (105° C) continuous service
- Irrigation Version:
150° F (66° C) continuous service
- PVC Version:
140° F (60° C) continuous service

Pressure Ratings

Metallic Sensor	At 100° F	_____
220BR	400 psi	
220SS	400 psi	
Plastic Sensor	At 100° F	_____
220PVS	100 psi	

Recommended Design Flow Range

- 0.5 to 30 ft/sec
- Initial detection below 0.3 ft/sec

Accuracy

- ± 1.0% of full scale over recommended design flow range
- ± 4.0% of reading within calibration range

Repeatability

- ± 0.3% of full scale over recommended design flow range

Linearity

- ± 0.2% of full scale over recommended design flow range

Transducer Excitation

- Quiescent current 600uA@8VDC to 35VDC max.
- Quiescent voltage (V_{high})
Supply Voltage - (600uA * Supply impedance)
- ON State (V_{Low}) Max. 1.2VDC@40mA current limit (15W+0.7VDC)

Output Frequency

- 3.2 Hz to 200 Hz

Output Pulse Width

- 5 msec ±25%

Electrical Cable for Standard Sensor Electronics

- 20 feet of two-conductor AWG 20 with AWG 22 drain wire shielded U.L. type PTLC wire provided for connection to display or transmitter unit. Rated to 105° C. May be extended to a maximum of 2000 feet with similar cable and insulation appropriate for application.

Electrical Cable for IR Sensor Electronics

- 48 inches of U.L. Style 116666 copper solid AWG 18 wire w/ direct burial insulation. Rated to 105° C.

Example: 2 20		BR	00	0	5	-	1	2	1	1
STYLE	Standard Flow	20								
MATERIAL	Brass	BR								
	Stainless Steel	SS								
	PVC Sleeve w/Stainless Steel Trim	PVS								
SIZE	Insert Style for pipe sizes 3" and up	00								
ELECTRONICS HOUSING	PPS		0							
ELECTRONICS	FM/CSA Approved			4						
	Standard Flow (STANDARD)			5						
	IR-Irrigation			6						
O-RING	Viton®						0			
	EPDM (STANDARD)						1			
	Buna N						8			
SHAFT	Zirconia Ceramic							0		
	Tungsten Carbide (STANDARD)							2		
	316 Stainless Steel							6		
IMPELLER	Nylon (STANDARD)								1	
	Tefzel®								2	
BEARING	UHMWPE (STANDARD)									1
	Tefzel®									2
	Teflon®									3

Series 220 Sensors Ordering Matrix



Please see our website at www.badgermeter.com for specific contacts.

www.badgermeter.com

Data Industrial® is a registered trademark of Badger Meter, Inc.

Other trademarks appearing in this document are the property of their respective entities.

Due to continuous research, product improvements and enhancements, Badger Meter reserves the right to change product or system specifications without notice, except to the extent an outstanding contractual obligation exists. © 2012 Badger Meter, Inc. All rights reserved.

Badger Meter | PO Box 245036, Milwaukee, Wisconsin 53224-9536 | 800-876-3837 | infocentral@badgermeter.com