



**Badger Meter**

## Series 200

### 225/226 Hot Tap Flow Sensor

The Data Industrial® Series 200 flow sensors by Badger Meter feature a six bladed impeller design with a proprietary non-magnetic sensing mechanism. The forward swept impeller shape provides higher, more consistent torque and is less prone to be fouled by water borne debris. The forward curved shape coupled with the absence of magnetic drag provides improved operation and repeatability at lower flow rates. This is especially true where the impeller is exposed to metallic or rust particles found in steel or iron pipes. As the liquid flow turns the impeller, a low impedance square wave signal is transmitted with a frequency proportional to the flow rate. The signal can travel up to 2000 feet between the flow sensor and the display unit without the need for amplification. All sensors except irrigation versions are supplied with 20 feet of 2-conductor 20 AWG shielded U.L. type PTLC 105°C cable.

### MODEL 225BR AND 226BR/226SS SENSORS

The 225BR and 226BR/226SS sensors are used for flow measuring applications in most metallic or non-metallic pipes where it would be difficult to shut down or drain the line for installation or service. The model 225 features a gate valve for isolation. The model 226 uses a ball valve. If the pipe is to be hot tapped, the ball valve is recommended. The sensor mounts in a 2 inch NPT pipe saddle or Threadolet® for installation in pipe sizes from 3 inches to over 40 inches. Positioning nuts on the three threaded retaining rods allow the sensor to be accurately positioned to a standard insertion depth of 1-1/2 inches into the pipe. When this insertion depth is maintained and there are at least 10 upstream and 5 downstream diameters of straight uninterrupted flow, an accuracy of +/-1 percent of full scale can be obtained between flow velocities of 0.5 to 30 feet/second. Each sensor is equipped with an isolation valve and pipe nipple to allow the sensor to be installed in a pressurized pipe. This is accomplished by first attaching a saddle or Threadolet® to the pipe and screwing the nipple and isolation valve into the saddle or Threadolet fitting. A hole is then drilled through the pipe using a commercial tapping machine. When completed, the tapping apparatus is removed, the isolation valve is closed, and the sensor is installed using a Model HTT Hot Tap Tool.

**NOTE: The overall length of the sensor tube is 18 inches (457 mm), however, a clearance height of 35 inches (127 mm) should be allowed for the fully extended length of the sensor tube outside the isolation valve.**

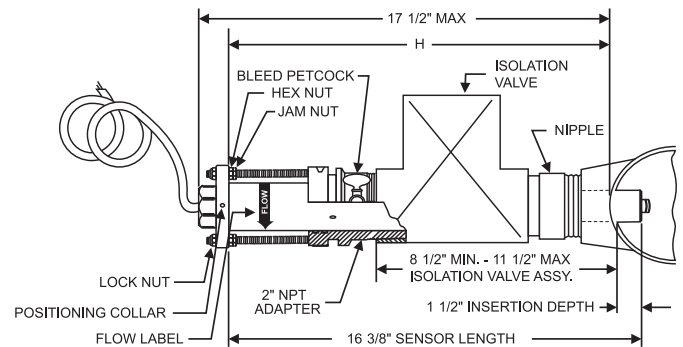

**NOTE: ALL DIMENSIONS ARE FOR REFERENCE ONLY. TO REMOVE THE FLOW SENSOR THERE MUST BE 35" OF CLEARANCE ABOVE THE OUTSIDE WALL OF THE PIPE. A CUTTING TOOL MAY REQUIRE ADDITIONAL CLEARANCE.**

#### Models 225/226 Dimensions



## SPECIFICATIONS

### Wetted Materials for all sensors

- (see ordering matrix)

### Sensor Sleeve and Hex Adapter for 225BR and 226BR

- Sleeve: Admiralty Brass, UNS C44300
- Hex Adapter: Valve Bronze, UNS C83600

### Sensor Sleeve and Hex Adapter for 226SS

- 316 Series Stainless Steel

### Temperature Ratings

- Standard Version: 221°F (105°C) continuous service
- Irrigation Electronics: 150°F (66°C)

### Pressure Ratings

At 100°F \_\_\_\_\_

225BR 300 psi

226BR 400 psi

226SS 400 psi

### Recommended Design Flow Range

- 0.5 to 30 ft/sec
- Initial detection below 0.3 ft/sec

### Accuracy

- ± 1.0% of full scale over recommended design flow range
- ± 4.0% of reading within calibration range

### Repeatability

- ± 0.3% of full scale over recommended design flow range

### Linearity

- ± 0.2% of full scale over recommended design flow range

### Transducer Excitation

- Quiescent current 600uA@8VDC to 35VDC max.
- Quiescent voltage ( $V_{high}$ )  
Supply Voltage  $-(600uA * \text{Supply impedance})$
- ON State ( $V_{Low}$ )  
Max. 1.2VDC@40mA current limit (15Ω+0.7VDC)

### Output Frequency

- 3.2 Hz to 200 Hz

### Output Pulse Width

- 5 msec ±25%

### Electrical Cable for Standard Sensor Electronics

- 20 feet of 2-conductor 20 AWG shielded U.L. type PTLIC wire provided for connection to display or analog transmitter unit. Rated to 105°C. May be extended to a maximum of 2000 feet with similar cable and insulation appropriate for application.

### Electrical Cable for IR Sensor Electronics

- 48 inches of U.L. Style 116666 copper solid AWG 18 wire with direct burial insulation. Rated to 105°C.

		Example: 2									
<b>STYLE</b>		25	BR	00	0	5	-	1	2	1	1
Hot Tap Insert - Gate Valve	25										
Hot Tap Insert - Ball Valve	26										
<b>MATERIAL</b>			BR								
Brass											
Stainless Steel (Model 226 Only)			SS								
<b>SIZE</b>				00							
Insert Style											
<b>ELECTRONICS HOUSING</b>					0						
PPS											
<b>ELECTRONICS</b>						4					
FM/CSA Approved											
Standard Flow (STANDARD)						5					
IR-Irrigation						6					
<b>O-RING</b>									0		
Viton®									1		
EPDM (STANDARD)									8		
Buna N											
<b>SHAFT</b>										0	
Zirconia Ceramic										2	
Tungsten Carbide (STANDARD)										6	
316 Stainless Steel											
<b>IMPELLER</b>											1
Nylon (STANDARD)											2
Tefzel®											
<b>BEARING</b>											1
UHMWPE (STANDARD)											2
Tefzel®											3
Teflon®											

Series 225 & 226 Ordering Matrix



Please see our website at [www.badgermeter.com](http://www.badgermeter.com) for specific contacts.

[www.badgermeter.com](http://www.badgermeter.com)

Data Industrial® is a registered trademark of Badger Meter, Inc.

Other trademarks appearing in this document are the property of their respective entities.

Due to continuous research, product improvements and enhancements, Badger Meter reserves the right to change product or system specifications without notice, except to the extent an outstanding contractual obligation exists. © 2012 Badger Meter, Inc. All rights reserved.

Badger Meter | PO Box 245036, Milwaukee, Wisconsin 53224-9536 | 800-876-3837 | [infocentral@badgermeter.com](mailto:infocentral@badgermeter.com)