

The Badger® Series 228PV wireless flow sensor system includes the flow sensor in a tee, radio frequency (RF) transmitter complete with mounting kit, and RF receiver / pulse transmitter. This system eliminates the need for expensive signal wires from the sensor output. The battery powered flow sensor performs flow measurement and scaling and then transmits a total flow value to the battery powered RF transmitter. The transmitter sends an RF signal approximately every four seconds that the RF receiver detects. The RF receiver compares the previous flow total with the most recent flow total to generate a scaled pulse output or a frequency output that mimics our standard wired sensor outputs. Using PC software, which is part of the software installation kit, the pulse output can be scaled to represent the desired volume unit and number of output pulses per unit volume that best fits the application. Pulse width can also be adjusted to meet the requirements of an interfacing control system or monitor.



Optional equipment offered with the 228PV wireless system include two types of antenna kits and a software installation kit complete with software and programming cables. Additionally, DIN rail mounting clips are available. These accessories can be ordered by specifying the appropriate model number from the Sensor Selection Matrix.

228PV Wireless Flow Sensor

The four-bladed impeller design is rugged, non-fouling and does not require custom calibration. Coupled with the proprietary patented digital detection circuit, the sensor measures flow rate from 1 foot per second (FPS) to over 20 FPS regardless of conductivity or turbidity of the liquid. The flow sensor generates a frequency which is proportional to flow rate. An integral microcontroller measures the impeller frequency and uses the appropriate K factor and offset values to compute the flow rate. By means of integration, the volume total is calculated. The output signal to the RF transmitter is a scaled output pulse. An internal lithium battery provides power for the flow sensor and is encapsulated to ensure moisture resistance.

Wireless Badger® ORION® RF Transmitter

The ORION transmitter operates in the 902-928 MHz frequency band at a power level which requires no FCC licensing. The transmitter is powered using an internal lithium battery and is encapsulated to ensure moisture resistance. It is factory programmed and requires no configuration.

Wireless ORION RF Receiver

The ORION receiver is powered using an external alternating current (AC) or direct current (DC) power supply. The wireless receiver receives the scaled total from the transmitter. Further scaling and unit conversion can be programmed into the receiver via a PC. The optically-coupled scaled-pulse output emulates a dry-contact closure to ensure interfacing into various types of controller inputs. The frequency output version provides the same output as our standard wired flow sensors. An external antenna is required for the receiver to detect the transmitted signal.

Sensor Selection Matrix

Example: 2 | 28 | PV | xx | 0 | W | - | 1 | 2 | 3 | 1 | X | X | X

STYLE	Tee Mounted	28	PV	xx	0	W	-	1	2	3	1	X	X	X
MATERIAL	PVC													
SIZE	1.5"	15												
	2"	20												
	3"	30												
	4"	40												
ELECTRONICS HOUSING	Acetal Housing w/ Fortron Polyphenylene Sulfide (PPS) Tip	0												
ELECTRONICS	Scaled Pulse Output					W								
	Frequency Output					U								
O-RING	EPDM							1						
SHAFT	Tungsten Carbide								2					
IMPELLER	420 Stainless Steel									3				
BEARING	UHMWPE (ultra-high molecular weight polyethylene)										1			
ANTENNA	No Option												0	
	Low Profile Type A355LP Antenna												1	
	Whip Type A355 Antenna												2	
SOFTWARE INSTALLATION KIT	No Option													0
	A301W-20 Cable, IR Cable, Software													1
MOUNTING	No Option													0
	DIN Rail Mounting Clips													1

Wireless 228PV Sensor (1½" to 4")



SPECIFICATIONS

Wetted Materials (Except Tee)

- Refer to the Sensor Selection Matrix

Tee for 228PV

- Schedule 80 PVC per ASTM D-2462 and D-2467. Virgin, unplasticized PVC resin, Type 1 cell classification 12454-B. Fittings and solvent carry approval for potable water by NSF and IAMPO.

Power Requirements

- Flow sensor-lithium battery powered (typical battery life > 5yr)
- ORION® transmitter-battery powered (typical battery life > 10yr)
- ORION receiver-external power 12-24VAC/VDC
Current Draw:
36 mA @ 12 VDC
16 mA @ 24 VDC
40 mA rms@ 12 VAC rms
30 mA rms@ 24 VAC rms

Recommended Flow Range

- 5 to 20 FPS
- Extended flow range 1 to 20 FPS

Accuracy

- Standard ± 2% of rate
- Repeatability ± 0.5%

SENSOR PRESSURE RATINGS

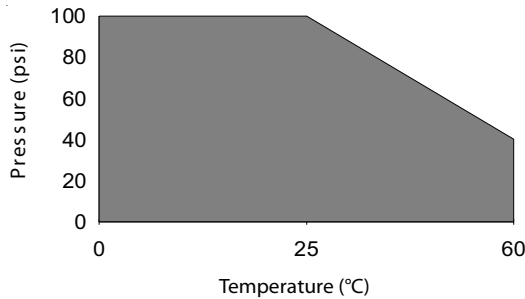

MINIMUM SCALED PULSE OUTPUT

- Scaled pulse output from the sensor and ORION RF receiver are programmed using PC software. Minimum recommended pulse output from the sensor for various "tee" sizes are listed below. (Based on 15 FPS flow velocities)

Tee Size	Gal/Pulse
1.5"	1
2"	1
3"	10
4"	10

Maximum Operating Temperature

- 32 - 150°F (0 - 65°C)

Sensor Pressure Drop

- 0.5psi or less at 10 FPS for all pipe sizes 1.5" diameter and larger

Programming

- Sensor and transmitter programming is accomplished using PC software via an infrared (IR) link
- ORION RF receiver programming is accomplished using PC software via the A301W-20 connector cable

Flow Sensor

Programmable Parameters

- K & Offset dependent upon pipe size
- Flow units (gpm, gph, lps, lpm, ft³/sec, ft³/min, m³/sec, m³/min)
- Scaled pulse output (units/pulse)

ORION Receiver

Programmable Parameters

- Serial number (unique to the ORION Transmitter ID)
- Volume units (gallons, ft³, m³, liters)
- Scaled pulse output (units/pulse)
- Scaled pulse output (pulse width)

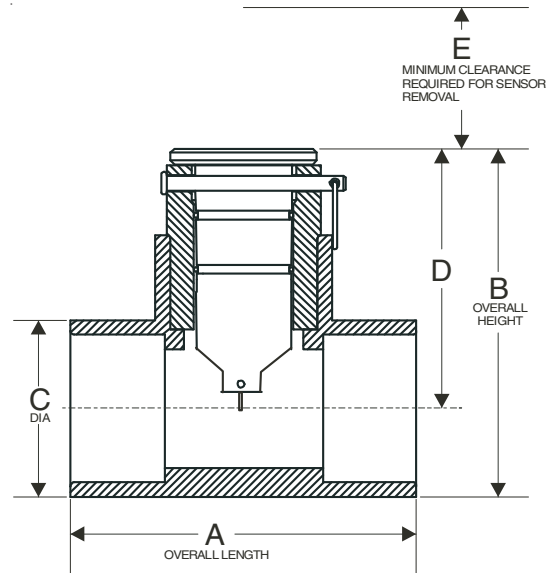

Series No. Complete	228PV152W-1201	228PV202W-1201	228PV302W-1201	228PV402W-1201
A	5.0" (127mm)	5.63" (143mm)	6.50" (165mm)	7.38" (187mm)
B	5.16" (131mm)	5.64" (143mm)	6.83" (173mm)	6.83" (199mm)
C	2.38" (60mm)	2.88" (73mm)	4.23" (107mm)	5.38" (137mm)
D	3.97" (101mm)	4.20" (107mm)	4.68" (119mm)	5.10" (130mm)
E	5.5" (139.7mm)	5.5" (139.7mm)	5.5" (139.7mm)	5.5" (139.7mm)

Badger®, Data Industrial®, and ORION® are registered trademarks of Badger Meter, Inc.



Please see our website at www.badgermeter.com for specific contacts.

Copyright © Badger Meter, Inc. 2009. All rights reserved.

Due to continuous research, product improvements and enhancements, Badger Meter reserves the right to change product or system specifications without notice, except to the extent an outstanding contractual obligation exists.



BadgerMeter, Inc.

P.O. Box 581390, Tulsa, Oklahoma 74158
(918) 836-8411 / Fax: (918) 832-9962
www.badgermeter.com