

**Badger®  
Model 320**

**Programmable Scaled Pulse  
Output Transmitter**

**Installation &  
Operation Manual**

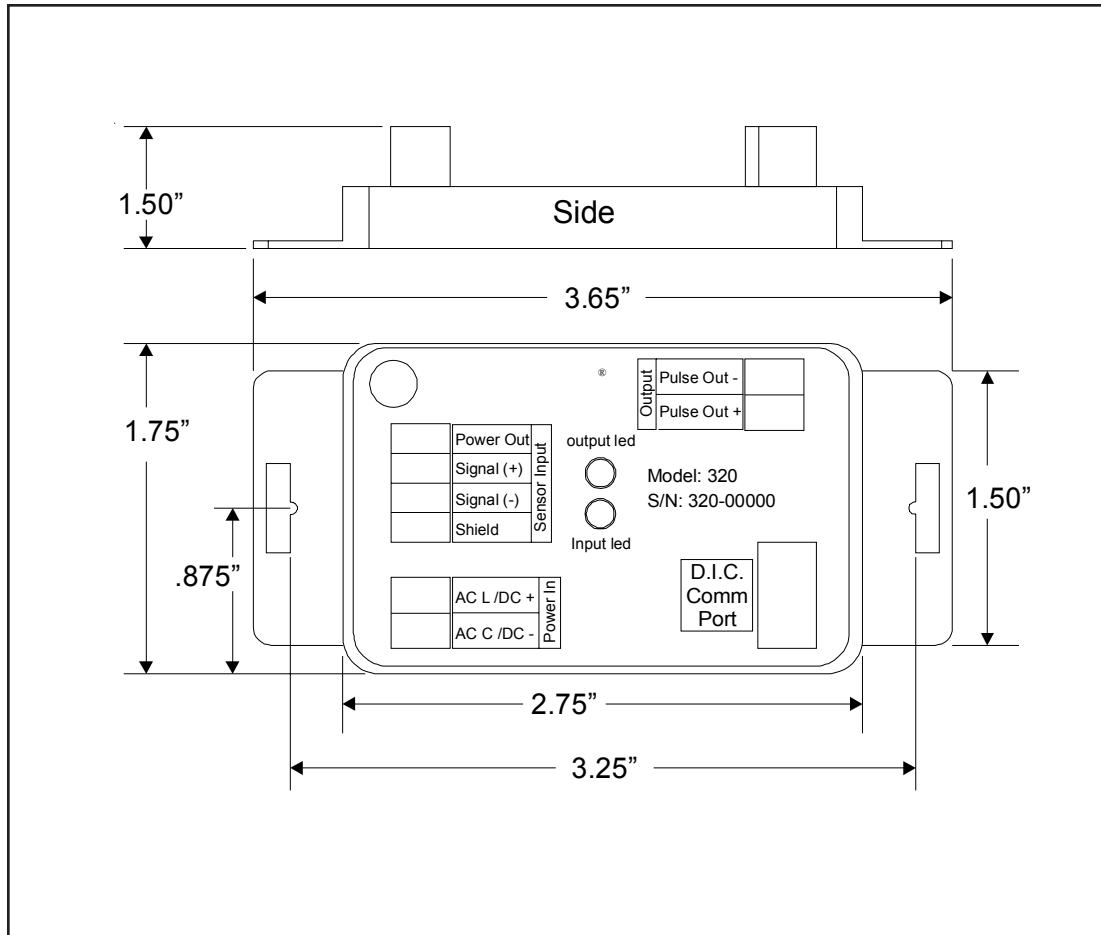

## Mechanical installation

The Model 320 may be surface mounted onto a panel, attached to DIN rails using adapter clips or wall mounted using two optional enclosures.

## Location

Although the Model 320 is encapsulated, all wiring connections are made to exposed terminals. The unit should be protected from weather and moisture in accordance with electrical codes and standard trade practices.

In any mounting arrangement, the primary concerns are ease of wiring and attachment of the programming cable.

The unit generates very little heat so no consideration need be given to cooling or ventilation.

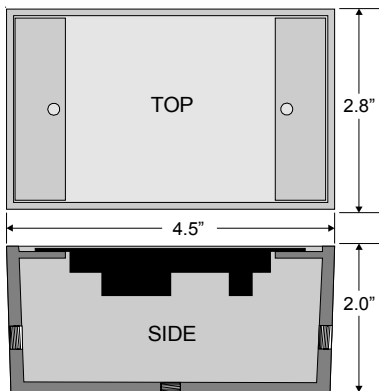

**Figure 2: 320 Optional Enclosure Dimensions**

## Surface Mount Installation

The Model 320 may be mounted to the surface of any panel using double sided adhesive tape or by attaching fasteners through the holes in the mounting flanges of the unit.

## DIN Rail Mounting

Optional clips snap onto the mounting flanges allowing the Model 320 to be attached to DIN 15, 32, 35 mm DIN rail systems.

## Wall Mounting

Optional metal and plastic enclosures are available to mount the Model 320 to a wall when no other enclosure is used. The enclosure is first attached to the wall using fasteners through its mounting holes.

After wiring, the transmitter may be attached to the enclosure with the terminal headers facing in using the slots in the mounting flanges. As an alternate mounting arrangement, the Model 320 may be fastened to the box cover using double-sided adhesive tape.

## Model 320 Electrical Installation

Per standard wiring practices, the power must be off before making any wire connections. The terminal strips have removable plug-in connectors to make wiring easier.

1. Refer to Figures 3 and 4 for terminal connections and wiring example.
2. Connect DC power supply positive (+) or AC Line to terminal marked AC L /DC (+).
3. Connect DC power supply negative (-) or AC Common to terminal marked AC C /DC (-).

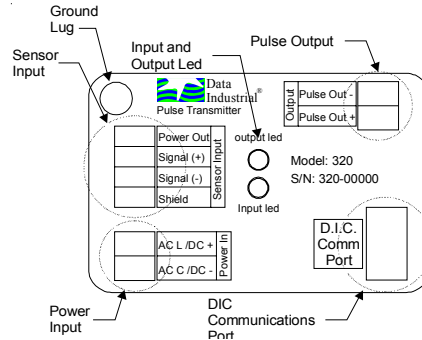

**Figure 3: Model 320 Terminal Locations**

4. If wiring to Series 200 sensor, connect the red wire to Signal (+) terminal, black wire to Signal (-) terminal and the shield to Shield terminal (Disregard shield for the IR sensors).

If wiring to Series 4000 sensor, connect the red wire to Power Out terminal, clear wire to Signal (+) terminal, black wire to Signal (-) terminal, and shield wire to Shield terminal.

If wiring to a sine wave output sensor consult factory.

5. Connect Pulse(+) from pulse input device to Pulse Out(+) of 320, connect Pulse(-) from pulse input device to Pulse Out(-) of 320.
6. For maximum EMI Protection, connect Model 320 ground lug to panel ground.
7. Ensure that all connections are tight, then plug connector into header.

## Note:

Included with every Model 320 is a 320IK kit containing a screw, lock washer and ground lead to connect the Model 320 to Earth Ground. This will help prevent electrical interference from affecting the Model 320's normal operation.

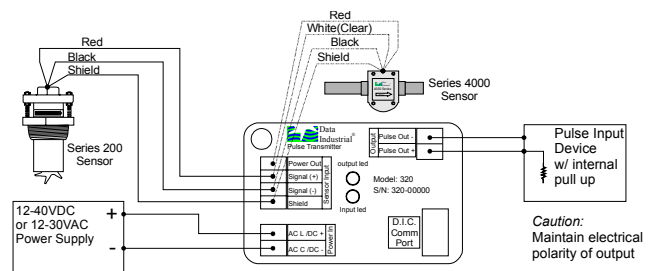

**Figure 4: Model 320 Wiring to a generic pulse device and Series 200 or Series 4000**

## Communications cable wiring

Field calibration requires a Data Industrial A320 Programming kit (consisting of a custom cable and software) and a PC running Windows® 9x, ME, NT, 2000 or XP. In order to program, the Model 320 must be connected to power, and the A301 cable must be connected to the Model 320 Comm port connector and an available DB9 COM port on a computer.

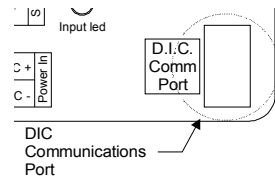

**Location of the DIC Communication Port**

### Note:

The Data Industrial A301 Cable will work with all 300 Series products. However the older version of the cable (A300) does not have sufficient bandwidth to work with the newer 340 Series Transmitters or SDI Flow Sensors.

## Programming Software Installation

### Floppy Installation

Place the software installation Disk 1 into the floppy drive and run the setup.exe program to install.

### CDROM Installation

Software CD into the CDROM drive and it should auto-start then Click software and click the product name for what software you want installed and the installation will begin.

### Web Installation

Data Industrial provides free programming software updates via the Internet for all of 300 Series devices. The Installation software can be found at the Data Industrial web site ([www.dataindustrial.com](http://www.dataindustrial.com)) in the support section.

### Model 320 Programming

Programming the Model 320 is accomplished by installing the Data Industrial programming software on a computer and entering data on templates of the Windows® based program.

1. Load the interface software into the computer.
2. Connect the computer to the Model 320 transmitter using the Data Industrial A301 communications cable. Plug A301 cable to the socket labeled "D.I.C Comm Port" taking care to properly align the tab on the plug and socket to maintain polarity then plug the DB9 connector of the Data Industrial A301 communications cable to an available PC com port that has the Model 320 software installed.
3. Connect the Model 320 transmitter to a power supply.

4. Open the interface software and select the appropriate COM PORT as shown in the dialog box below.

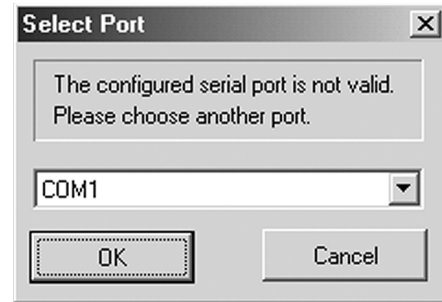

5. Open the Parameters Screen as shown below.

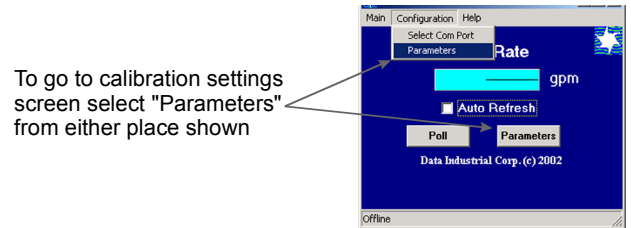

6. Program using diagram below as a reference

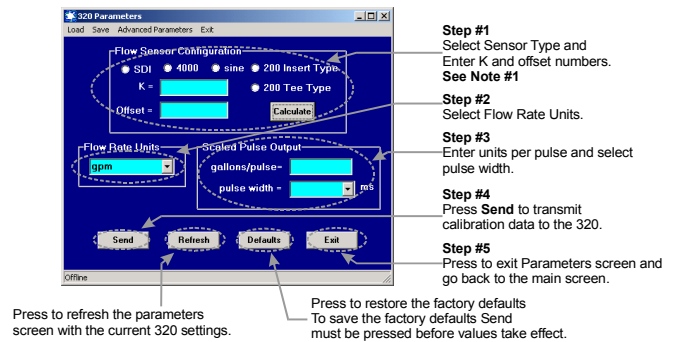

### Note #1

Sdi - If the SDI sensor type is selected the required K and offset values can be found the the SDI owners manual.

4000 - If the 4000 sensor type is selected, click the choose button and select the sensor from the pull down box that appears.

Sine - Provided for connection to sensors which have a sine wave output. Please consult sensor manufacturer for the calibration settings.

200 Insert Type - If the 200 Insert Sensor type is selected the required K and offset can be found the the 200 owners manual or if the manual is not handy the calculate button can be pushed and an inside pipe diameter can be entered and once calculate is pressed a K and offset will automatically be entered in.

200 Tee Type - If the 200 tee type is selected, click the choose button and select the sensor from the pull down box that appears.

## Model 320 Specifications

### Power:

12-35 VDC +/- 5%  
12-24 VAC +/- 10%  
reverse and over voltage protected to 40VDC

### Input Frequency:

0.4 to 10 KHz

### Transient Suppression:

Complies with IEC-801-4 electrical burst, fast transient specification.

### Pulse Output:

Isolated solid state switch in any standard or custom flow total units adjustable 50 mS to 1.0 second pulse output width in 50 mS increments.

maximum sinking current: 100mA @ 36 VDC

### Temperature:

operating: -20°F to 158°F (-29°C to 70°C)  
storage: -40°F to 185°F (-40°C to 85°C)

## Warranty

Data Industrial Corporation ("Seller") of 11 Industrial Drive, Mattapoisett, Massachusetts 02739-0740, U.S.A., warrants to the original purchaser of its product that such product manufactured by Data Industrial Corporation shall be free from defects in materials or workmanship when installed, serviced and operated according to Data Industrial Corporation instructions or in other such normal use. This warranty is effective for a period of 12 months from the date of installation by the Purchaser or 18 months from the date of shipment by the "Seller" whichever occurs or terminates first. This limited warranty does not cover damage or loss resulting from corrosion or erosion caused by acids or other chemicals or by severe environmental conditions or negligent or improper installation or improper operation, misuse, accident, unauthorized repair or substitution of components other than those provided by the "Seller", and does not cover limited life components such as bearings, shafts, impellers where wear rate is a function of application and environment. Any component not manufactured by the "Seller" but included in its products shall not be covered by this warranty and is sold only under such warranty as the manufacturer may provide.

If Buyer or Purchaser wishes to make a claim hereunder, he shall send written notice of any defect within the warranty period, to "Seller" at the above address. "Seller" may at its sole option instruct Buyer to ship subject part, postage prepaid, to the "Seller" at above address or authorize a representative to inspect the part on site. "Seller" will at its sole option repair or replace any defective product covered by this warranty. If Buyer makes repairs or alterations to any product or part covered by this warranty without "Sellers" prior written approval, this warranty shall be null and void.

The foregoing shall constitute Buyers or Purchasers sole and exclusive remedy against "Seller", and no other remedy, including but not limited to, incidental or consequential damages for personal injury, loss of fluids, gases or other substances or for loss of profits or injury to property or person shall be available to the Buyer or Purchaser. The warranty extended herein shall be in lieu of any other implied warranty of merchantability or fitness for a particular purpose, and seller shall bear no liability for representatives or retail sellers. In no event shall Data Industrial Corporation be liable for any contingent, incidental, or consequential damage or expenses due to partial or complete inoperability of its product.

All rights reserved. No part of this work covered by the copyrights hereon may be reproduced or copied in any form or by any means - graphic, electronic, or mechanical, including photocopying, recording, taping, or information and retrieval systems -- without written permission of Data Industrial.

Badger® and Data Industrial® are registered trademarks of Badger Meter, Inc.



Please see our website at [www.badgermeter.com](http://www.badgermeter.com)  
for specific contacts.

Copyright © Badger Meter, Inc. 2009. All rights reserved.

Due to continuous research, product improvements and enhancements, Badger Meter reserves the right to change product or system specifications without notice, except to the extent an outstanding contractual obligation exists.



**BadgerMeter, Inc.**

P.O. Box 581390, Tulsa, Oklahoma 74158  
(918) 836-8411 / Fax: (918) 832-9962  
[www.badgermeter.com](http://www.badgermeter.com)