

Model RCM-2000

RESEARCH CONTROL®
Mag

Installation &
Operation Manual



SCOPE

This manual contains information concerning the installation, operation and maintenance of the RCM-2000. To ensure proper performance of the unit, the instructions should be thoroughly understood and followed

Keep the manual in a readily accessible location for future reference.

Changes and additions to the original edition of this manual will be covered by a “CHANGE NOTICE” supplied with the manual. The change notice will identify the sections in this manual where the changes have occurred.

UNPACKING & INSPECTION

1. If damage to the shipping container is evident upon receipt, request the carrier to be present when the product is unpacked.
2. If damage is found, request an inspection by the carrier's agent within 48 hours of delivery and file a claim with the carrier. **A claim for equipment damage in transit is the sole responsibility of the customer.**
3. Retain the container and all packing material for possible use in reshipment or storage.

TABLE OF CONTENTS

System Diagram.....	1
Installation.....	2
AC Power.....	3
Sensor & User I/O.....	3
Wiring Diagram	4
Digital Output Jumpers.....	5
Serial Port Jumpers	6
Overview.....	7
POR (Power on Reset).....	7
Rate.....	8
Vel.....	8
Tot.....	8
Sys.....	8
D1.....	8
Programming.....	9
Front Panel Programming.....	9
Menu Structure.....	9
Pushbutton Key Function.....	9
User Output programming.....	10
4-20mA Span Adj.....	10
4-20mA Zero Adj.....	10
Programming Set Point.....	10
Resetting Totalizer.....	11
LCD Contrast Adj.....	11
LCD Backlight Enable.....	11
User Setup Programming.....	12
Flow Units Selection.....	12
Tube Size Programming	12
User Selected Full Scale Flow Rate.....	13
Number of Pulses per Unit Volume.....	13
Low Flow Cutoff Programming.....	13
Output Response Programming	14
Specifications.....	15

System Diagram

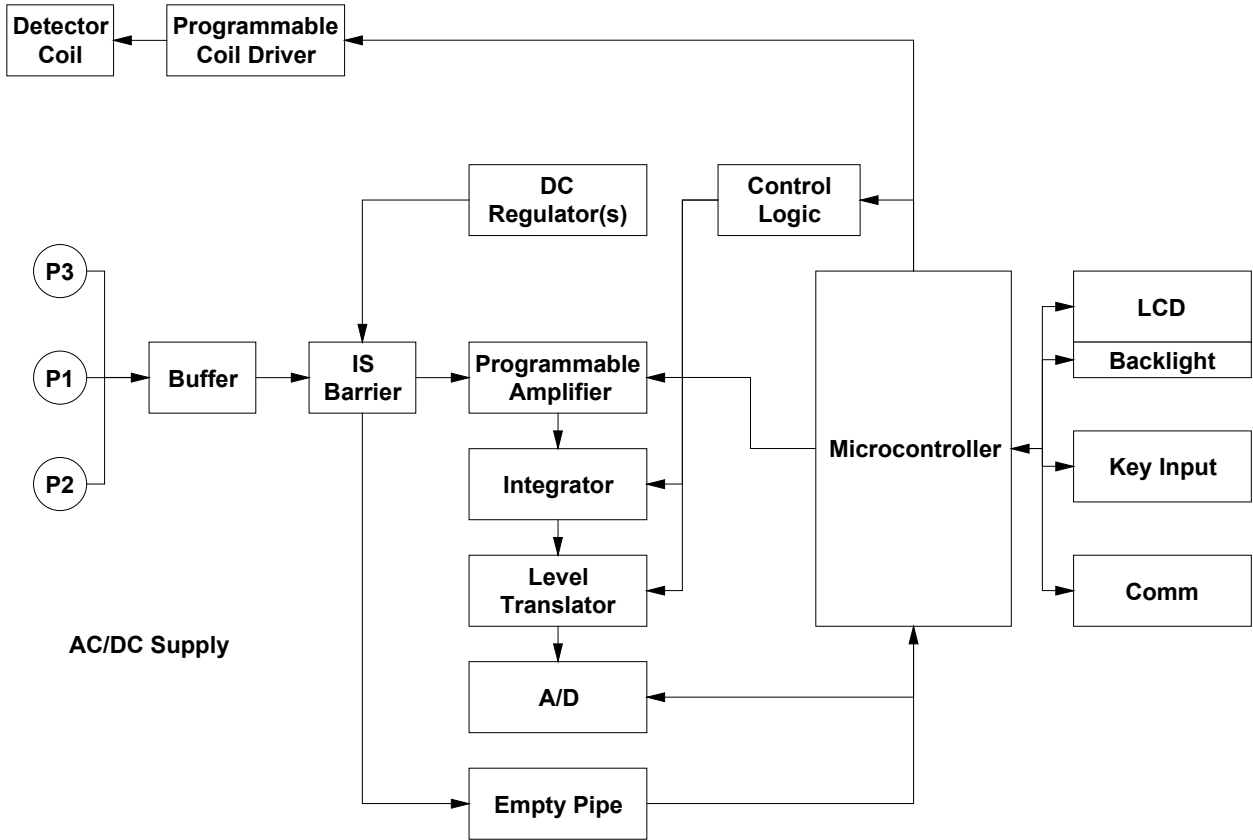

**Section
2**

INSTALLATION

Installation

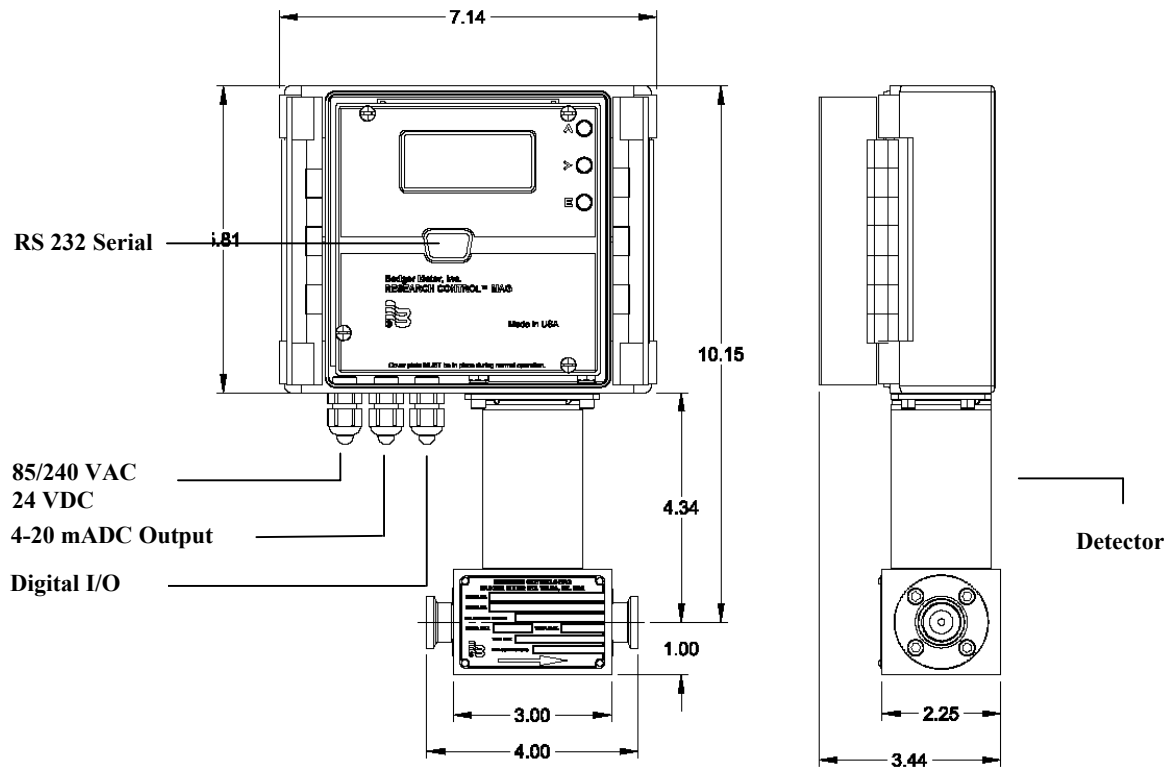

Note: I/O wiring should not be in close proximity or in the same conduit as any AC power, controller/driver, or relay wiring.

The enclosure is rated IP 66 (NEMA 4X) and can be mounted indoors or out. The PG Fittings provided must be tightened around any cables to maintain the rating.

Do not expose the electronics to vibration or direct sunlight. If an outdoor installation is required and intense sunlight is expected, provide a sun shade to reduce ambient temperature and to make the display easier to read.

The RCM-2000 detector and electronics are a matched at the factory and will have the same serial numbers. When replacing the detector there is a configuration file that can be downloaded through the front panel RS-232 serial port for simple setup.

Install RCM flow sensor in the process line. The arrow on the sensor tag indicates flow direction. The detector can be mounted with the electronics or

it can be remote mounted. Mounting position is not critical but if possible ensure that the electrodes are always wetted even at zero flow conditions. For vertical pipe runs, the fluid should move upwards. As with any metering device it should be upstream of any control valves. A good rule of thumb is the detector should always be mounted on the pressurized system side in a flow control system. This is mandatory for low flow applications below 250CCM.

Install interconnecting wires between RCM detector and the electronics. The shield needs to be connected on both ends of each cable. Important: Do not strip the shield more than 1 inch (2.5 cm) from conductors!

AC Power



AC power is clearly marked in the terminal block labeled TB1 located under the Front panel. The unit is designed to handle voltage from 90 to 240 VAC. The unit requires 5 VA for proper operation. Proper personnel shall wire the unit in accordance with local codes.

Green	GND
White	LO (Neutral)
Black	HI (Hot)

For power spikes a replaceable fuse is located on the board, just above AC power terminal. It is a 240 volt, 0.25 amp 5mm fuse.

Sensor & User I/O



The RCM-2000 main terminal block is located under the Front panel and can be easily accessed by removing the four screws. Except for AC power, and RS-232 communication port, all of the I/O connectors are brought out on a two row 22 pin terminal strip.

The wiring connections are made via two cables from the RCM Sensor.

1. Coil Cable – A three conductor cable connecting the RCM Sensor coil to the Magnet Current Connections in the electronics.
2. Sensor Cable – A five conductor cable connecting the RCM Sensor preamp to the electronics.

**Section
2**

INSTALLATION

Wiring Diagram

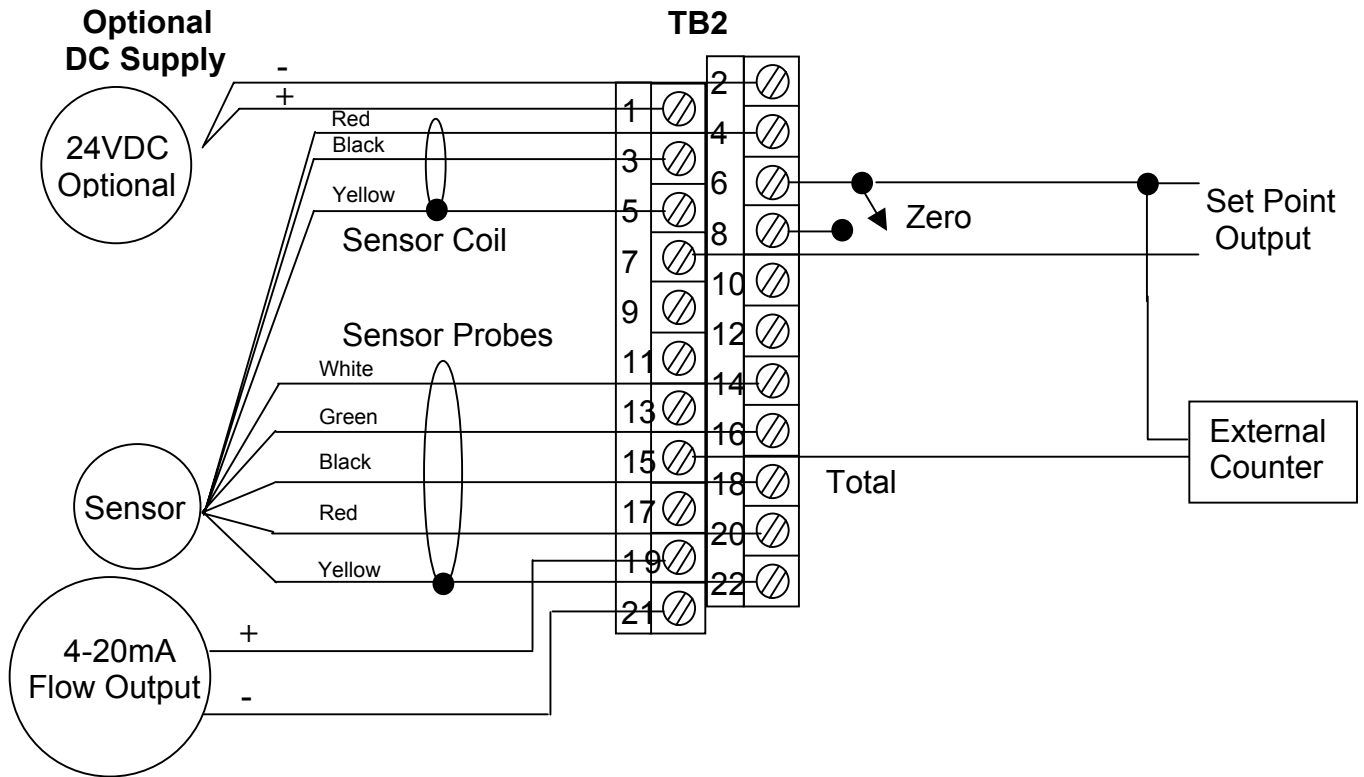

TB2 Pin	Function	Sensor wire color	Previous Marking
1	24VDC +		
2	24VDC -		
3	Magnet Current HI	Black	11
4	Magnet Current LO	Red	12
5	Magnet Current Shield	Yellow	13
6	Isolated GND		
7	Set Point 1 out Collector		
8	Zero In		
9	Set Point 1 out Emitter		
10	Empty Pipe output		
11	Option out Collector		
12	Empty Pipe input		
13	Option out Emitter		
14	Preamp 9VDC Power +	White	31
15	Frequency out Collector		
16	Preamp 9VDC Power -	Green	30
17	Frequency out Emitter		
18	Preamp Probe IN +	Black	46
19	4-20mA out +		
20	Preamp Probe IN -	Red	45
21	4-20ma out -		
22	Preamp Probe Shield	Yellow	44

**Section
2**

INSTALLATION

**Digital Output
Jumpers**

With J1 and J4, J2 and J5, J3 and J6 jumpers in place the output is an isolated 0-5VDC output. With the jumpers removed the outputs are Open Collector and are capable of switching 30VDC @ 50mA.

This type of output is duplicated for the totalizer, set point and optional outputs

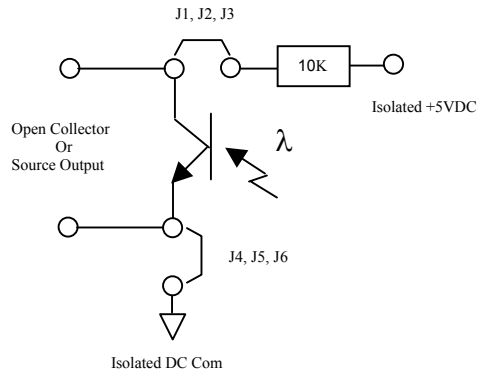

	J1	J2	J3	J4	J5	J6
Totalizer (0-5VDC)	X			X		
Totalizer Open Collector						
Set Point (0-5VDC)		X			X	
Set Point Open Collector						
Optional (0-5VDC)			X			X
Optional Open Collector						

Section
2

INSTALLATION

Serial Port Jumpers

With the two jumpers installed vertically the serial output can be used with a straight through DB-9 serial cable and connect directly to a PC serial input port. With the jumpers installed horizontally the serial port can be used to connect directly into a PDA

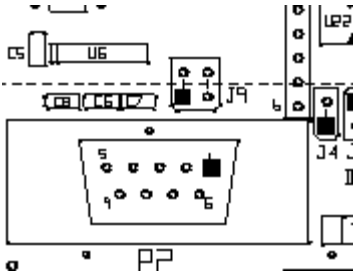

Overview

The RCM-2000 detector contains a nonconductive ceramic tube mounted in a stainless steel housing. Two DC pulsed electromagnetic coils are mounted in the stainless housing outside of the tube. Two platinum electrodes are inserted into the ceramic tube perpendicular to the coils. When the coils are energized, a magnetic field is created across the whole diameter of the tube. When a conductive fluid flows through this magnetic field, a voltage is induced across the electrodes based upon Faraday's Law.

$$e_s = kDB_f \overline{V_f}$$

This voltage is directly proportional to the average flow velocity of the fluid and is picked up by the two electrodes. This induced voltage is then amplified and processed digitally by the converter to produce a very accurate analog or digital output signal. The signal can then be used to indicate flow rate and totalization or to communicate to remote controllers. The main advantages of this technology are that with no parts in the flow stream, there is no pressure loss, the accuracy is not affected by temperature, pressure, viscosity, density or flow profile and with no moving parts, there is practically no maintenance required

POR (Power on Reset)

After power is applied the microcontroller goes through an initialization process. As it goes through this process the following screens are displayed

Display shows the installed firmware revision.

Normal Flow Measurement screen shows Rate, Velocity, Totalization, and system status

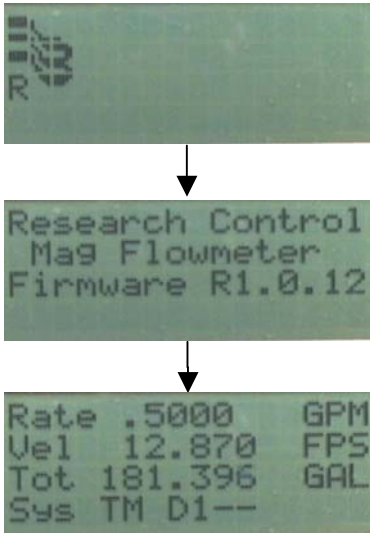

OPERATION

Rate	<p>The current flowrate in the programmed units. The flow units available are;</p> <table style="margin-left: 40px; border: none;"> <tr> <td>Gallons per Minute</td> <td>GPM</td> </tr> <tr> <td>Cubic Centimeters per Minute</td> <td>CCM</td> </tr> <tr> <td>Liters per Minute</td> <td>LPM</td> </tr> </table>	Gallons per Minute	GPM	Cubic Centimeters per Minute	CCM	Liters per Minute	LPM
Gallons per Minute	GPM						
Cubic Centimeters per Minute	CCM						
Liters per Minute	LPM						
Vel	<p>The current Velocity in Feet per Second or Meters per Second. Units determined by Rate setting. FPS if flowrate is GPM. MPS if flowrate is CCM or LPM.</p>						
Tot	<p>Totalized flow since system was last reset.</p>						
Sys	<p>System Status Codes</p> <ul style="list-style-type: none"> OK No Error or Warning Flags present – Normal Operation OR Over Range – Either reduce the flow or change the user selected flow range. Always make sure the user selected flow rate is greater than or equal to the expected maximum flow. If an over-range condition exists the analog output will not track it. The totalizer will however indicate properly even past the user specified flow rate. 42 4-20mA Warning – Check the 4-20mA wiring and make sure there isn't an open circuit. If this output is not used and you don't want to see this warning, attach a jumper wire between terminal TB2-19 and TB2-21. LC Low Flow Cutoff – No action should be needed unless you have the low flow cutoff set below where the user wants it. The Factory Default is 2%. TM Test Mode – If the board is placed in the Factory Test Mode for some reason, the meter will not indicate live flow. CH Coil High – This message could appear if there is a short circuit or partial short circuit in the detector coil wiring or sensor. Another possibility is that the coil current setting is too high. CL Coil Low – This normally happens when the coil is not connected or in an open circuit mode. Another possibility is that the coil current setting is too low. 						
D1	<p>This indicates the status of the set point output.</p> <ul style="list-style-type: none"> ON Flow rate is at or above the programmed set point value. -- Flow rate is below the programmed set point value. 						

Programming







Front Panel Programming

Menu Structure

The three buttons are used to program the RCM-2000 for a specific application, as well as other features.

The unit is setup and programmed from the front panel. The menu structure is a “drill down” structure with menus and submenus providing access to specific programming parameters and allowing certain options and features to be selected. There are 6 main menus with a set of submenus for all but one of the main menus.

Pushbutton Key Function

-   The **UP** key is used for scrolling a menu selection or increasing a programmable parameter
-   The **Right** key is used to select a menu item or decreasing a programmable parameter.
-   The **Enter** key allows you access the next menu or to store programming values.

When entering numerical values, a flashing cursor appears on the number to be changed. The programming parameter is changed using a decade increasing method to speed up programming. By pressing and holding the up or down key the least significant digit is changed 10 times then the next significant digit begins to change until it has change 10 times. This continues up into the most significant digit until the key press is terminated. Most all of the programming values will rollover from max to min or max to min values.

User Output programming

```
Setup
>Outputs
back      E=End
```

```
analog output
  change
>next Parameter
back      E=End
```

4-20mA Span Adj

```
analog output
  7457 span
^ UP > down
      E=Enter
```

4-20mA Zero Adj

```
analog output
  53731 zero
^ UP > down
      E=Enter
```

Programming Set Point

```
set point %
  change
>next Parameter
back      E=End
```

```
set point %
  50 %
^ UP > down
      E=Enter
```

These menus are entered by first pressing the Enter key.

Use the up arrow to move the > prompt next to Outputs location on the screen, then press the right arrow key to select the next set of menus.

Press the up arrow key until the prompt > is next to change then press the right arrow key to enter the analog output adjustment menus.

At this point you can adjust the 4-20mA output span. Use a calibrated 4 1/2 digit DMM set for 199.99mA range and attach the test leads to TB2 pins 19 and 21. Use the up and right arrow keys to change the span value on line 2. Monitor the current indication until the current is set for 20.00 +/- .001. Then press the enter key to store the span value and proceed to the next menu.

The 4-20mA output zero can now be adjusted. Use a calibrated 4 1/2 digit DMM set for 19.999mA range and attach the test leads to TB2 pins 19 and 21. Use the up and right arrow keys to change the zero value on line 2. Monitor the current indication until the current is set for 4.00 +/- .001. Then press the enter key to store the zero value and proceed to the next menu.

The next menu selection is the set point adjustment. Use the up arrow to move the > prompt to the change location on the screen, then press the right arrow key to select the next menu.

Use the up or right arrow to adjust the set point value from a value ranging from 0 to 100%. To save the value press the Enter key. This action will automatically move to the next menu.

SETUP

Resetting Totalizer

```
Reset Totals
  change
>next Parameter
back      E=End
```

```
Reset Totals
 243.024
^ clear
      E=Enter
```

The next menu selection is the Totalizer reset. Use the up arrow to move the > prompt to the change location on the screen, then press the right arrow key to select the next menu.

Use the up arrow to clear the totalizer to zero. To move on to the next menu press the Enter key.

LCD Contrast Adj

```
Contrast adj
  change
>next Parameter
back      E=End
```

```
Contrast adj
  48
^ UP > down
      E=Enter
```

The next menu selection is the LCD contrast adjustment. Use the up arrow to move the > prompt to the change location on the screen, then press the right arrow key to select the next menu.

Use the up or right arrow to adjust the contrast to the desired setting. Depending upon whether the RCM-2000 has a 6 or 12 o'clock viewing angle LCD the number will range between 20 to 70. To save the value press the Enter key. This action will automatically move to the next menu.

LCD Backlight Enable

```
Backlight Cntl
  change
>next Parameter
back      E=End
```

```
Backlight Cntl
  ON
^ UP > down
      E=Enter
```

The next menu selection is the LCD backlighting enable menu. Use the up arrow to move the > prompt to the change location on the screen, then press the right arrow key to select the next menu.

Use the up or right to enable (ON) or disable (OFF) the LCD backlighting feature. This feature does consume several watts of continuous power do not use in low power applications. To save this feature press the Enter key.

```
analog output
  change
>next Parameter
back      E=End
```

This key will automatically move to the beginning analog output menu.

User Setup Programming

```
Setup
>Outputs
back      E=End
```

Flow Units Selection

```
unit
change
>next Parameter
back      E=End
```

```
unit
Gallon/min
> next
E=Enter
```

Tube Size Programming

```
Tube Size
change
>next Parameter
back      E=End
```

```
Tube Size
3.200 mm
^ up > down
E=Enter
```

These menus are entered by first pressing the Enter key.

Use the up arrow to move the > prompt next to Setup location on the screen, then press the right arrow key to select the next set of menus.

The first setup menu selection is the Flow unit selection menu. Use the up arrow to move the > prompt to the change location on the screen, then press the right arrow key to select the next menu.

Use the right arrow to select the flow rate units (GPM, LPM, CCM). When selecting the flow units the velocity units are automatically selected based upon whether they are Metric (mps) or English (fps). To save the units press the Enter key. This action will automatically move to the next menu.

Note. When changing units remember to check the full scale flow, and the pulse output and change to the desired values. It is also a good practice to reset the totalizer to prevent mixed units in the totalizer value.

This menu selection changes the flow tube I.D. Use the up arrow to move the > prompt to the change location on the screen, then press the right arrow key to select the next menu.

Use the up or right arrow to adjust the tube I. D. The tube size is always represented in mm. To save the value press the Enter key. This action will automatically move to the next menu.

Note. If the tubes size is changed the Sensor configuration file must be downloaded through the serial port to ensure maximum accuracy.

**Section
4**

SETUP

User Selected Full Scale Flow Rate

```
Full Scale flow
change
>next parameter
back      E=End
```

```
Full Scale flow
2.00000 GPM
^ UP > down
E=Enter
```

This menu selection changes the full scale flow. Use the up arrow to move the > prompt to the change location on the screen, then press the right arrow key to select the next menu.

Use the up or right arrow to adjust the full scale flow. To save the value press the Enter key. This action will automatically move to the next menu.

This setting dictates the analog output full scale, but does not affect the pulse per unit output.

Number of Pulses per Unit Volume

```
Pulse output
change
>next parameter
back      E=End
```

```
Pulse output
1000.0Pulse/GAL
^ UP > down
E=Enter
```

This menu selection scales the pulse output and the indicated volume total. Use the up arrow to move the > prompt to the change location on the screen, then press the right arrow key to select the next menu.

Use the up or right arrow to adjust the number of pulses per unit volume. The units have been automatically selected in the previous units menu. To save the value press the Enter key. This action will automatically move to the next menu.

This setting dictates the analog output full scale, but does not affect the pulse per unit output.

The selection range for the number of pulses for gallons and liters is 1-1000, 1 for CCM.

Low Flow Cutoff Programming

```
low flow cutoff
change
>next parameter
back      E=End
```

```
low flow cutoff
2 %
^ UP > down
E=Enter
```

This menu selection programs when a zero condition exists. Use the up arrow to move the > prompt to the change location on the screen, then press the right arrow key to select the next menu.

Use the up or right arrow to adjust the low flow cutoff. To save the value press the Enter key. This action will automatically move to the next menu.

**Section
4**

SETUP

Output Response Programming

```
Output Response  
change  
>next Parameter  
back      E=End
```

```
Output Response  
Medium  
^ UP > down  
E=Enter
```

```
unit  
change  
>next Parameter  
back      E=End
```

```
Setup  
>Outputs  
  
back      E=End
```

This menu selection programs response time of the meter. Use the up arrow to move the > prompt to the change location on the screen, then press the right arrow key to select the next menu.

Use the up or right arrow to adjust the response between slow, medium, and fast. Use the fast setting for velocities > 2fps, and applications that have low flow noise and require quick batching. Use the medium setting for normal applications. Use the slow setting for low velocity or high flow noise applications.

To save the value press the Enter key. This action will automatically move back to the units menu.

Pressing the End key again will move to the main menu. Use the up arrow key to move to another set of menus or press the End key to move to the main display

Specifications

RCM Detector	<p>Type Pulsed DC</p> <p>Conductivity Minimum 0.5μS/cm (0.5μmho/cm)</p> <p>Liner Ceramic</p> <p>Electrodes Platinum</p> <p>Seal Material EPDM Std. – Buna N, Viton or Teflon available</p> <p>End Connections 316 SS Std. – Kynar or Hastolloy-C available</p> <p>Housing 300 Series SS</p> <p>Rating NEMA 4X (IP67)</p> <p>Max CIP Temperature 265°F (130°C)</p> <p>Max Pressure 360 psig (25 bar)</p> <p>Maximum cable length 200 feet (60.96 m)</p>
Detector Cable	<p>Coil Cable 2 conductor common shield (foil-shield or braid shield)</p> <p style="padding-left: 100px;">AWG 18 to22 e.g. Belden Cable 9462; 9962; 8760</p> <p style="padding-left: 100px;">(22 AWG / 20AWG / 18AWG)</p> <p>Sensor Cable 4 conductor (2 conductor foil-shield 2 conductor unshielded) AWG 22 e.g. Belden Cable 8730; 8724; 8722 (22AWG).</p>
Output	<p>4-20 mADC isolated; 800 ohms max. The output is monitored to detect open circuit and has RFI and surge protection built in.</p> <p>Three Isolated Outputs , Sink or Source rated at 30VDC @ 50mA</p> <p style="padding-left: 40px;">Pulse (Volume)</p> <p style="padding-left: 40px;">Set Point (% F.S.)</p> <p style="padding-left: 40px;">Optional (Batch, etc.)</p> <p>RS-232 Serial Port, 9600 Used for local serial access for downloading data, programming the meter, or viewing status information.</p>
Input	<p>One Isolated Input, O.C. or contact closure</p> <p style="padding-left: 100px;">Force Zero</p>

**Section
5**

Display	4 line, 16 character per line LCD display. Indicating up Flow, Velocity, Totalization, System, and I/O status.
Programming	Front panel accessible 3 pushbuttons
Power	85/240 VAC, 50/60 Hz (fuse rating 0.1A) or 24 VDC @ 200 mA continuous. 5watt power dissipation
Accuracy	Standard: $\pm .5\%$ of reading for velocities $> 0.8\text{fps}(.24\text{mps})$ $\pm 0.004\text{fps} (.00125\text{mps}) < 0.8\text{fps}(.24\text{mps})$
Electronic Enclosure	IP66/NEMA 4X standard Enclosure 6”H x 6”W x 3.5”D Temperature range: -4° to 160° F (-20° to 70° C)



Please see our website at
www.badgermeter.com
for specific contacts.

Due to continuous research, product improvements and enhancements, Badger Meter reserves the right to change product or system specifications without notice, except to the extent an outstanding bid obligation exists.



BadgerMeter, Inc.

6116 E. 15th Street, Tulsa, Oklahoma 74112

(918) 836-8411 / Fax: (918) 832-9962

www.badgermeter.com