

Model PRT

**Portable Register Tester
P/N 34027-000**

Technical Brief

DESCRIPTION

APPLICATIONS: The Portable Register Tester (PRT) is designed to test the operation of all RECORDALL® and Easy-Read® local registers. The PRT can also operate READ-O-MATIC® Generators, High Resolution Transmitters, Recordall Transmitter Registers (RTR®) and RECORDALL Instrumentation Transmitters.

OPERATION: The portable register tester has a bayonet and adapter ring which positions registers properly on the unit. A forward-reverse switch is provided to allow the register to be run in either direction.

POWER: Two standard "D" cells provide power for the unit. Not supplied with the PRT, these cells are easily installed or replaced by removing two screws and lifting the cover.

MAGNETIC DRIVE: Designed for use with all Badger RECORDALL and Easy-Read registers and transmitters, the magnetic drive of the Portable Register Tester is identical to those used in the meter. Coupling problems can be readily detected with the PRT.

CARRYING STRAP: A sturdy nylon strap is provided for convenience and rugged field use.

ENCLOSURE: The enclosure is made of painted aluminum and secure closure is provided by four self-tapping screws.

SWITCH: The three-position slide switch provides Forward-Off-Reverse operation. This allows registers to be tested in normal operation, or reversed to reset local register totalizer accumulation to zero.

NOTE: HIGH RESOLUTION TRANSMITTERS AND RECORDALL TRANSMITTER REGISTERS (RTR) SHOULD NOT BE OPERATED IN REVERSE. REVERSE OPERATION WILL CAUSE IRREPAIRABLE DAMAGE TO THE REGISTER.

ADAPTER RING: RECORDALL local registers, READ-O-MATIC Generators, RECORDALL Transmitter Registers (RTR), High Resolution Transmitters and RECORDALL Instrumentation Transmitters can be operated using the adapter ring supplied with the PRT. Auxiliary devices such as an ohm meter are required to check the electrical output from these units.



SPECIFICATIONS

Battery	Two D Size Cells
Control	Forward-Off-Reverse Switch
Drive	Magnetically Coupled DC Motor
Enclosure	Painted .04" Aluminum
Dimensions	5¼" x 3" x 2½"
Weight	23 Ounces



DIMENSIONS

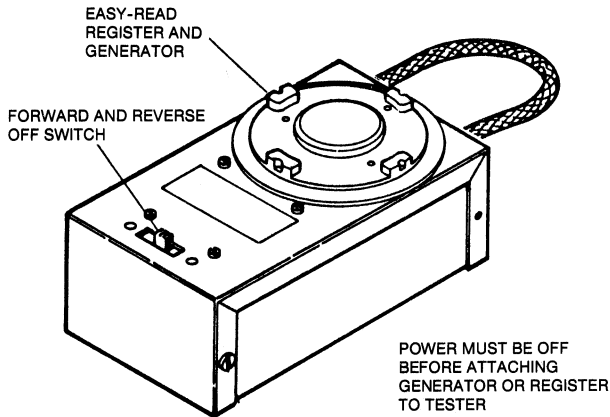
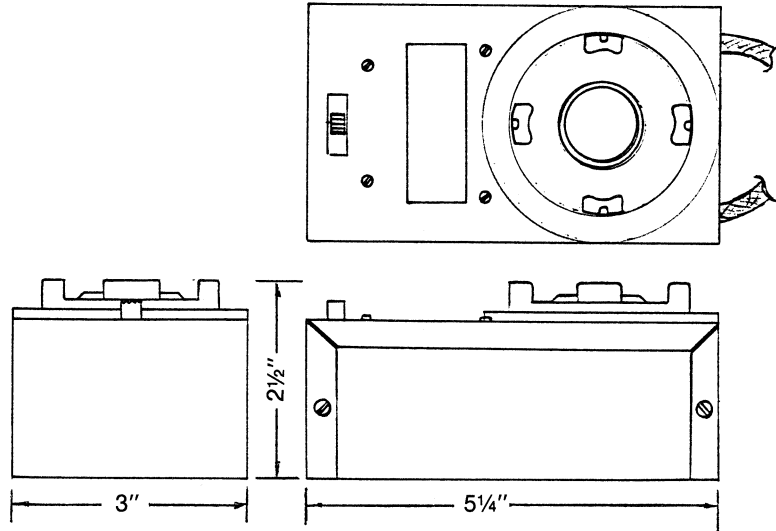

**PORTABLE TESTER
P/N 34027-000**

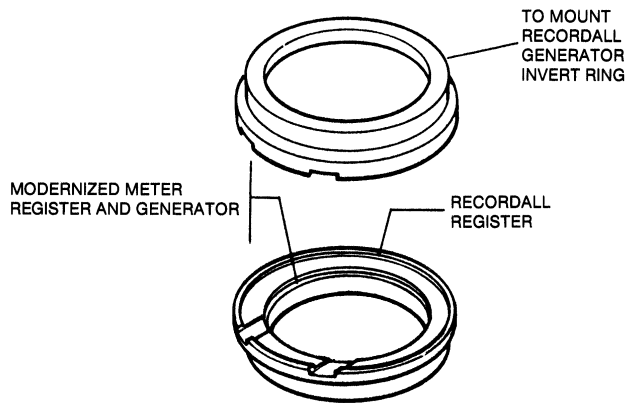

**ADAPTER RING MOUNTING
P/N 56075-001**

Recordall®, Easy-Read®, Read-O-Matic® and RTR® are registered trademarks of Badger Meter, Inc.



Please see our website at
www.badgermeter.com
for specific contacts.

Copyright © Badger Meter, Inc. 2001. All rights reserved, all data subject to change without notice.

Due to continuous research, product improvements and enhancements, Badger Meter reserves the right to change product or system specifications without notice, except to the extent an outstanding bid obligation exists.



BadgerMeter, Inc.

P.O. Box 245036, Milwaukee, WI 53224-9536
(800) 876-3837 / Fax: (888) 371-5982

www.badgermeter.com