

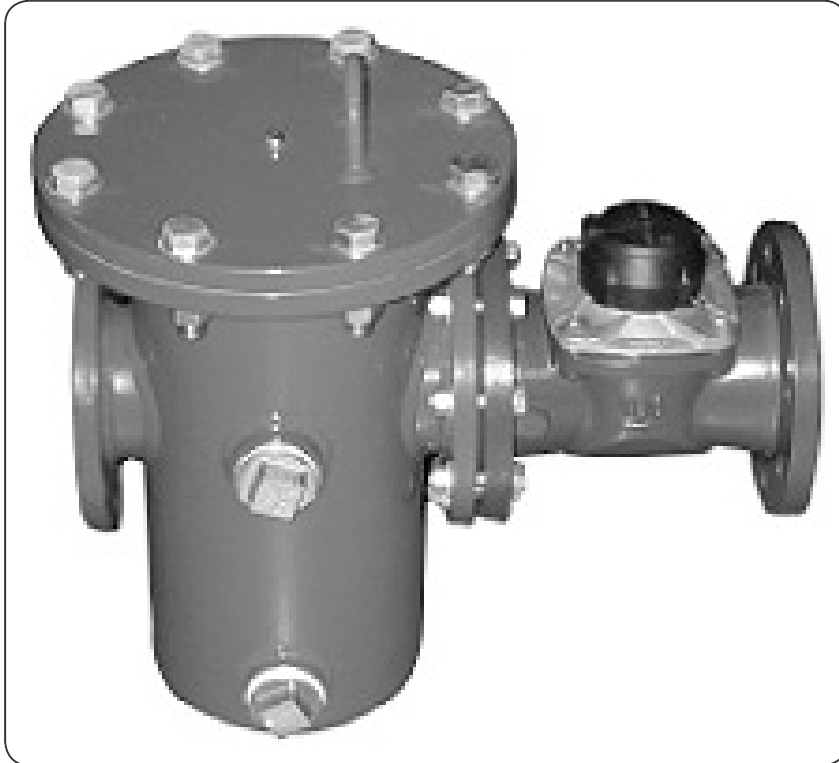

Badger Meter

Fire Series Meters
Sizes 3", 4", 6", 8" and 10"



IMPORTANT:
This manual contains important information.
READ AND KEEP FOR REFERENCE.

CONTENTS

PREFACE 5

SCOPE OF MANUAL.....5

CHANGES IN MANUAL5

DESCRIPTION5

UNPACKING AND INSPECTION 5

INSTALLATION..... 6

MAINTENANCE..... 7

CALIBRATION CHECK AND ADJUSTMENT 10

FSMA..... 11

Strainer 11

PREFACE

SCOPE OF MANUAL

This manual contains information concerning the installation, operation and maintenance of Badger® Fire Series Meters. To ensure efficient operation, the instructions in this manual should be thoroughly read and understood. Retain this manual in a location where it is readily available for reference.

CHANGES IN MANUAL

Changes or additions to the original edition of this manual will be covered by a "CHANGE NOTICE" supplied with the manual. The "CHANGE NOTICE" will explain any differences between the Fire Series Assembly received and the product described in this manual.

DESCRIPTION

MODEL FSMA-01 FIRE SERIES METER consists of at least a six times open area strainer and a 3", 4", 6", 8" or 10" Recordall® Turbo Series Meter with AWWA class II measuring chamber (depending on assembly size). The Fire Series Meter Assembly is designed to measure high volume usage, such as when a building's fire sprinklers are activated, through a single water supply line.

STRAINER is at least six times open area and is used exclusively in fire series systems to prevent clogging. The strainer is equipped with a 2" or 3" flushing outlet valve for flushing debris from the upstream side of the strainer screen.

TURBINE METER: Water flows into the meter's measuring element contacting the multi-vaned rotor. Flow readings are obtained by rotor revolutions transmitted by magnetic drive coupling through the meter's cover plate to the sealed register. Magnetic drive is achieved by a right angle worm drive, coupling the rotor to a vertical transmission spindle, driving a gear set rotating the magnet carrier. A ceramic magnet in a carrier rotates around a vertical axis. Rotor rotation is transmitted to the register gearing through this magnetic coupling.

The turbo measuring element is designed to greatly reduce wear by reducing friction potential between the moving parts of the rotor and bearing system. Less wear, in this critical area of the design, provides the utility manager with a lower life cycle cost for meter application. Throughout the normal operating range of the meter, the rotor floats between the thrust bearing system.

UNPACKING AND INSPECTION

To avoid damage in transit, Badger Fire Series Meters are shipped to the customer in special shipping containers. Upon receipt of shipment, be sure to follow these unpacking and inspection procedures:

NOTE: If damage to a shipping container is evident upon receipt of a meter, request that a representative of the carrier be present when the meter assembly is unpacked.

1. Carefully open the shipping container, following any instructions that may be marked on the container. Remove any cushioning material surrounding the product and carefully lift the meter assembly from the container. Keep the container and all packing material for possible use in reshipment or storage.
2. Visually inspect the meter assembly and applicable accessory devices for any signs of damage such as scratches, loose or broken parts or other physical damage that may have occurred during shipment.

NOTE: If damage is found, request an inspection by the carrier's agent within 48 hours of delivery. Then file a claim with the carrier. A claim for equipment damaged in transit is the responsibility of the customer.

OPERATING RANGES FOR FIRE SERIES METERS	
FIRE SERIES METER (FSMA)	
SIZES	GPM
3"	6 to 550
4"	10 to 1250
6"	20 to 2500
8"	30 to 4500
10"	50 to 7000

Registration Options: U.S. gallons, cubic feet, or cubic meters

INSTALLATION

Installation is made similar to placing a length of flanged end pipe in the line. The AWWA Class "D" steel flanged end design permits use in a wide range of applications. The meter must have a full flow of liquid for proper accuracy. It must be installed in horizontal applications only.

INSTALLING THE METER. Overall dimensions and laying lengths of each meter size are shown on the Technical Briefs. After reviewing the applicable dimensional requirements, choose an appropriate installation point in the piping and proceed as follows:

1. Measure precisely the overall length of the Fire Series Assembly with gaskets attached to the inlet and outlet flange connections.
2. Provide proper gap length in series piping.
3. Install meter in the pipeline so that the flow arrow on the meter housing points in the same direction as water flow.
4. With the Assembly and gaskets in place, tighten flange connection bolts.
5. To relieve possible strain on the piping, it is recommended that a support be used under the meter assembly where appropriate.

⚠ CAUTION

Turbine meters must operate in a completely filled line at all times. The downstream piping must always be arranged to provide sufficient back pressure to maintain a full line at the meter. By eliminating air in the line, as well as sudden flow surges, inaccurate registration and damage to the turbine mechanism can be avoided.

MAINTENANCE

This section is to information about general maintenance and servicing. instructions for disassembling the Recordall Turbo Series meters for servicing can be found in Section IV of Instruction Manual (RTS-IOM-5). A repair parts list, exploded views and other illustrations are provided as a supplement to this manual.

When the performance of the Fire Series Meter indicates a need for servicing of the Recordall Turbo Series meter, refer to the following instructions pertaining to removal, inspection and installation of service parts and assemblies. With the Recordall Turbo Series unitized construction, service is simplified with a reduction in required product maintenance training. Also refer to the illustrated repair parts list RTS-P-1 for part numbers of replaceable components for ordering information. If satisfactory repair cannot be achieved, contact Badger Meter, Inc.

BADGER METER products have been carefully designed to be as maintenance free as possible. However, depending upon installation location and condition of water being metered, maintenance may occasionally be required. The maintenance and inspection procedure can also be used as a guide to locating a problem in the unit that may be the cause of abnormal meter operation.

Meters can be serviced without removing them from the line. A typical installation would be equipped with drain and piping valves. To inspect or replace components of the head assembly, close the upstream and downstream valves. However, if the installation does not have a drain valve, proceed as follows (page 8) to relieve pressure.

⚠ WARNING

Upstream and downstream valves must be closed before attempting to remove meter head from housing or performing any service/maintenance requiring disassembly. Failure to do so can lead to head being "ejected" from housing, causing personal injury and/or property damage!

1. Loosen each of the head bolts about one and one-half turns. Do not completely remove the bolts.
2. If the O-ring between the meter head and the housing is secure and not leaking, pry the measuring element assembly loose by inserting a screwdriver blade where the head and housing join together.

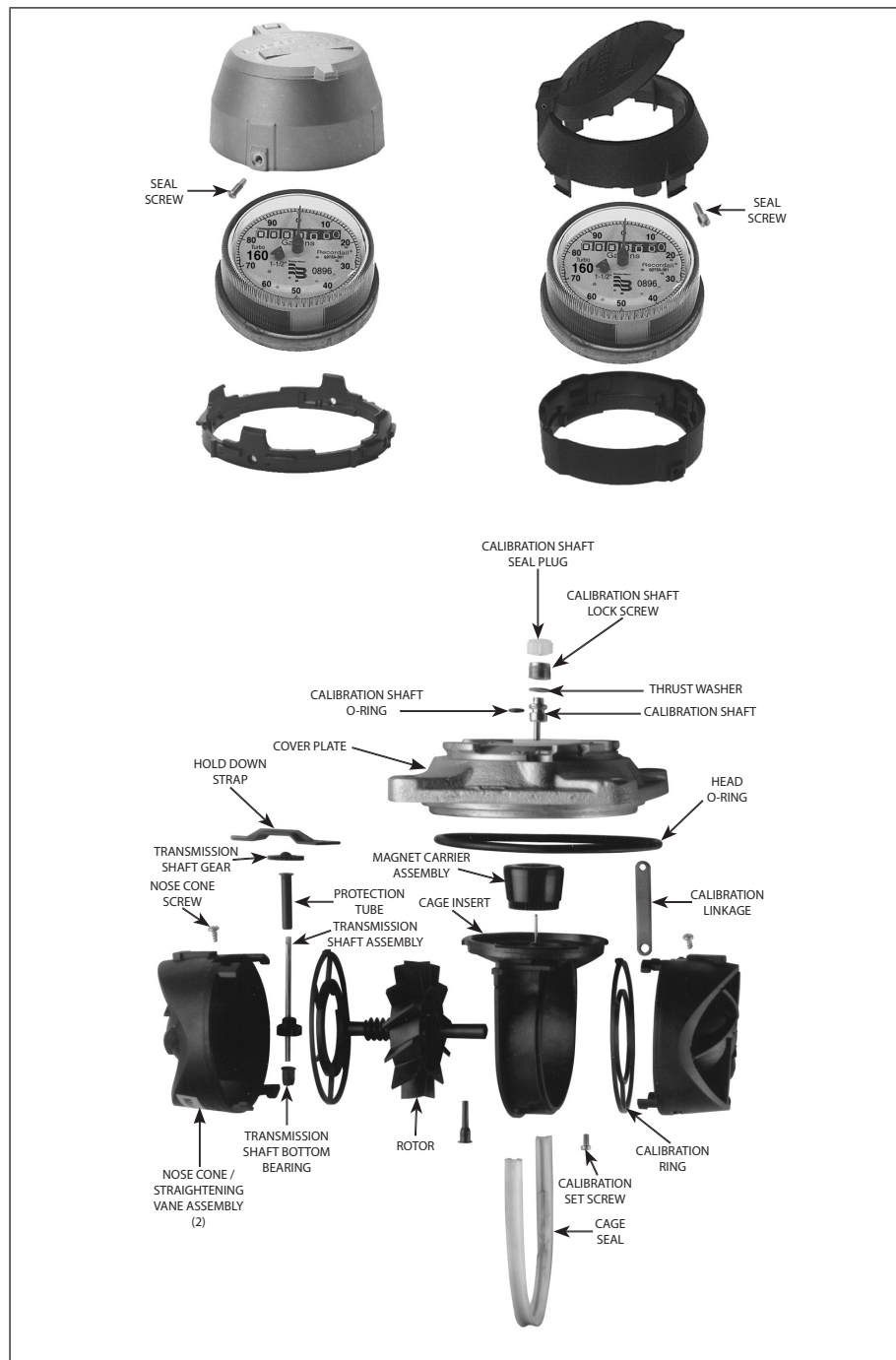

Figure 1. Registering and Measuring Element Assembly, 3" to 4"

⚠ CAUTION

Be sure that any water coming out of the meter head does not spray onto electrical equipment to create a shock hazard.

3. Allow the meter to drain and relieve internal pressure.
4. When pressure is relieved, remove the head bolts. Lift the measuring element assembly from the housing.

Periodic preventive check valve maintenance, is highly recommended and should be practiced according to schedule to assure continuous accuracy and trouble-free performance of your check valve. The valve is water lubricated and should be regularly inspected for corrosion, obstructions in the water-ways and for freedom of movement for all working parts. The frequency of the inspections is dependent upon the quality of the water supply and authority having jurisdiction. Assure all equipment is adequately protected to prevent freezing and physical damage. Repair all leaks.

⚠ WARNING

Periodic preventive check valve maintenance, is highly recommended and should be practiced according to schedule to assure continuous accuracy and trouble-free performance of your check valve. The valve is water lubricated and should be regularly inspected for corrosion, obstructions in the water-ways and for freedom of movement for all working parts. The frequency of the inspections is dependent upon the quality of the water supply and authority having jurisdiction. Assure all equipment is adequately protected to prevent freezing and physical damage. Repair all leaks.

Any inspection or maintenance which involves putting a control valve out of service may eliminate the fire protection of that system. Prior to proceeding notify all authorities having jurisdiction. Consideration should be given to employment of a Fire Patrol in the affected area.

1. STRAINER in the Fire Series Meter is there to protect the meter and other components in the line from debris. The strainer is sized to provide maximum protection with minimal head loss. Inspection of the strainer screen, and/or flushing and cleaning the strainer screen is recommended on an annual basis. Cleaning or flushing should be performed more frequently for meters installed in water with high levels of debris or contaminates.

2. YEARLY INSPECTION is advised for meters installed in water with high levels of debris or contaminates. Measuring chamber should be cleaned and inspected.

CALIBRATION CHECK AND ADJUSTMENT

For calibration check and adjustment of the Turbo Series meters, please see page four of Instruction Manual (RTS-IOM-5).

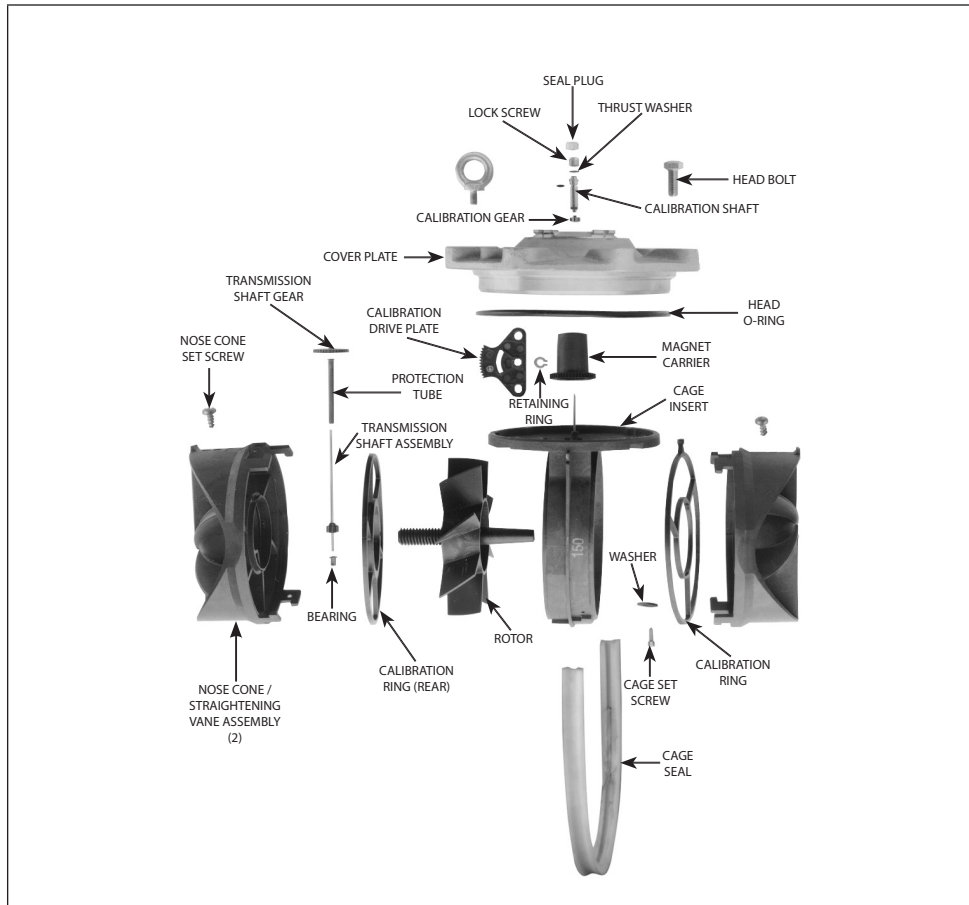
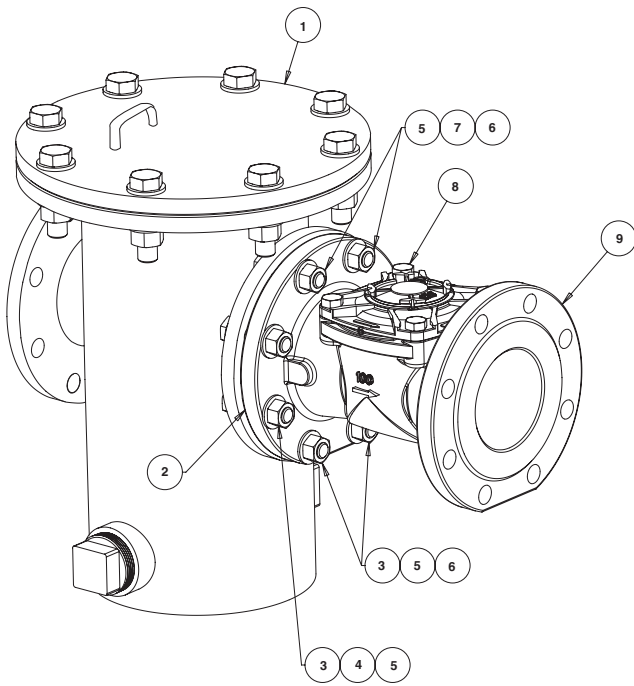

Figure 2. Registering and Measuring Element Assembly, 6" to 10"

FSMA



ITEM NO.	PART
1	(See Strainer)
2	Gasket
3	Bolts
4	Nuts
5	Washers
6	Jam Nut (6" & 8" only)
7	Stud (6" & 8" only)
8	Seal Bolts
9	Cast Iron Turbo Series Meter

Strainer

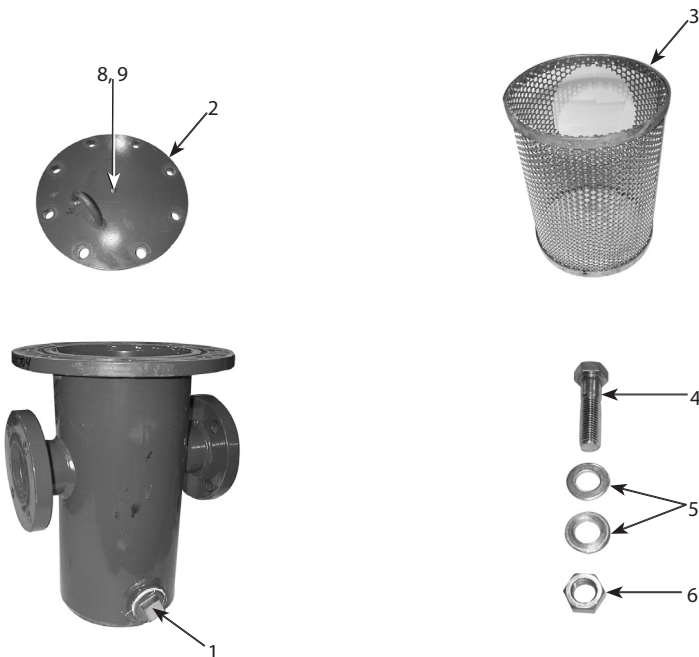

ITEM NO.	PART
1	Drain Plug
2	Register Flat Lid (Bronze)
3	Strainer Element
4	Bolt
5	Washer
6	Nut
7	Cover O-ring (not pictured)
8	Vent Screw
9	Nylon Washer

Copyright 2011 Badger Meter, Inc. All rights reserved.



Due to continuous research, product improvements and enhancements, Badger Meter reserves the right to change product or system specifications without notice, except to the extent an outstanding contractual obligation exists.

Badger Meter | P.O. Box 245036, Milwaukee, Wisconsin 53224-9536
800-876-3837 | infocentral@badgermeter.com | www.badgermeter.com