

Series 1500 - Flow Monitor

Leak Control - Gravity Flow System

Application Brief

SYSTEM

In eastern Washington State, some irrigation districts supply water to farms from transmission mains high in the hills. The elevation head is high enough to operate the farmers' sprinkler systems without use of pumps.

PROBLEM

If an irrigation main should break during an irrigation cycle, a tremendous amount of washout can occur before the leak is detected.

SOLUTION

Badger Meter's Model IR220B and the Model 1500-010 digital flow monitor with programmable relays can be used to operate a butterfly valve and shut down a section of the system if the flow exceeds a preset limit, indicating a break.

RECOMMENDATIONS

The Model IR220B sensors can be mounted on any type or class of irrigation pipe by using a service saddle with a 2" NPT outlet. Because the sensor circuitry is encapsulated, it can be mounted on the pipe in the ground with access by means of a valve box.

The Model 1500-010 can be mounted up to 2,000 feet away from the sensor. A typical location may be at the valve location or power source. The normally open contacts from the set point relay should be wired to a motor-operated butterfly valve. The operator would program a relay to close at a flow rate somewhat larger than the biggest sprinkler zone. This can be determined by counting the number of sprinklers when each zone is running.

The programming is accomplished via the menu driven software of the Model 1500-010. The relay can be programmed to energize above the flow rate of the biggest sprinkler zone. A time delay from 10-100 seconds may be entered. This time delay will allow for normal surges in flow as a result of zones being switched. Once the specified flow rate is exceeded, the timer starts. When the time delay passes, the relay is switched. This will close the butterfly valve. The latch will hold the valve closed and light an alarm until the system can be checked.

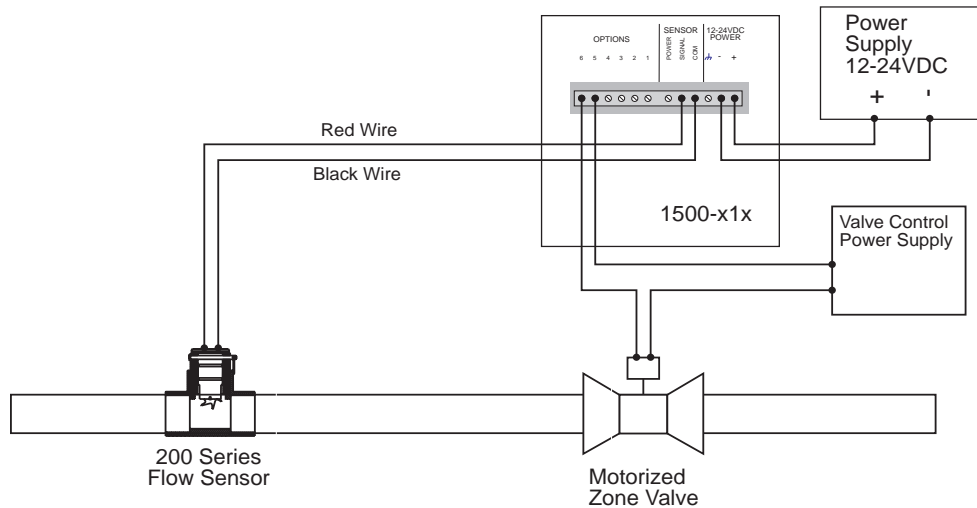

DAB-009-01
(previously known as AN11)

2-08



Please see our website at www.badgermeter.com
for specific contacts.

Copyright © Badger Meter, Inc. 2008. All rights reserved.

Due to continuous research, product improvements and enhancements, Badger Meter reserves the right to change product or system specifications without notice, except to the extent an outstanding contractual obligation exists.



BadgerMeter, Inc.

6116 E. 15th Street, Tulsa, Oklahoma 74112
(918) 836-8411 / Fax: (918) 832-9962
www.badgermeter.com