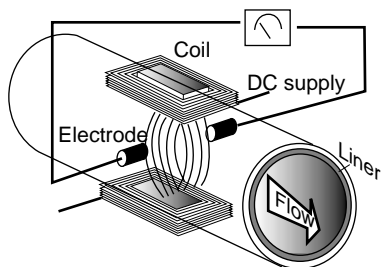

GENERAL

Badger's Magnetoflow line is the result of 35 years of research and field use in electromagnetic flow meters. Based on Faraday's law of induction, these meters can measure almost any liquid in the food & beverage industry or any other application that requires sanitary liquid handling. Designed, developed and manufactured under the strictest quality standards, this meter ranks among the best in the market. It's sophisticated, processor based signal conversion represents the state of the art in the industry with accuracies of 0.25% or better. The standard PTFE liner and Alloy C electrode material insure maximum compatibility and minimum maintenance over a long operating period.

OPERATION

The flow meter is basically a stainless steel tube lined with a nonconductive material. Outside the tube two DC powered electromagnetic coils are positioned diametrically opposing each other. Perpendicular to these coils, two electrodes are inserted into the flow tube. When the coils are energized, a magnetic field is created across the whole diameter of the pipe. When a conductive fluid flows through this magnetic field, a voltage is induced across the electrodes. This voltage is directly proportional to the average flow velocity of the fluid and is picked up by the two electrodes. This induced voltage is then amplified and processed digitally by the converter to produce a very accurate analog or digital signal. The signal can then be used to indicate flow rate, totalization or to communicate to remote sensors and controllers. The main advantages of this technology are that with no parts in the flow stream, there is virtually no pressure loss, the accuracy is not affected by temperature, pressure, viscosity, density or flow profile and with no moving parts, there is practically no maintenance required.

**APPLICATION**

Because of its inherent advantages over other more conventional technologies, this meter can be used in the majority of industrial sanitary flow applications. Whether the fluid is water or something very viscous, contains a moderate amount of solids or requires special handling, this meter will be able to accurately measure it. Today Magnetoflow meters are successfully being used in many industries including food, beverage and pharmaceutical, handling fluids such as milk, beer, pastes, syrups, and many other hard to measure fluids.

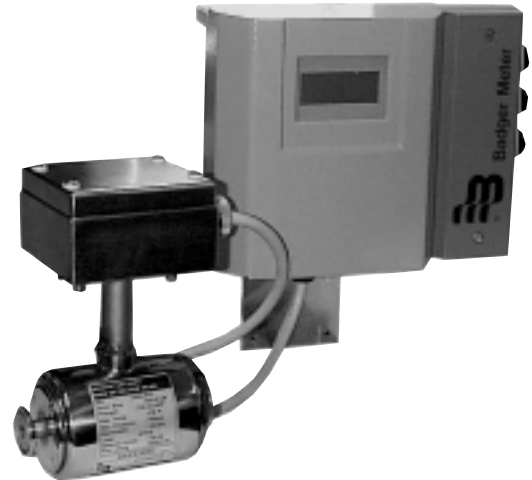
**Magnetoflow Sanitary with Primo****FEATURES**

- 0.25% accuracy independent of fluid viscosity, density and temperature
- Unaffected by fluids most solids contained in fluids
- Pulsed DC magnetic field for zero point stability
- No pressure loss for low operational costs
- Long life corrosion resistant liner (PTFE)
- Calibrated in state of the art facilities
- Measurement largely independent of flow profile
- Measures fluids with as low as 0.5 micromhos/cm conductivity
- 3A approved
- Remote Amplifier mount style only



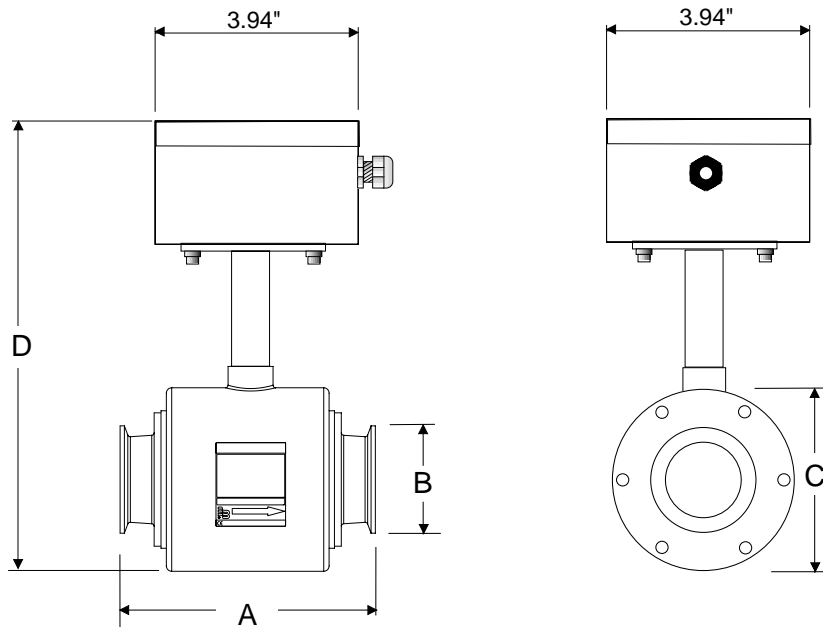

Meter with junction box for remote Primo® converter

	A		B		C		D		Est. Weight with Primo		Flow Range			
											GPM		LPM	
inches mm	inch mm	inch mm	inch mm	inch mm	inch mm	inch mm	inch mm	Lbs	Kg	Min	Max	Min	Max	
3/8" 10	7.1 180	.992 25.2	2.8 70	8.3 210	12 5.5	0.034	11.4	0.13	43					
1/2" 15	7.1 180	.992 25.2	2.8 70	8.3 210	12 5.5	0.06	20	0.23	76					
3/4" 20	7.1 180	.992 25.2	2.8 70	8.3 210	12 5.5	0.13	45.4	0.52	171					
1" 25	7.1 180	1.984 50.4	2.8 70	8.3 210	13 6	0.24	80	0.92	305					
1 1/2" 40	7.9 200	1.984 50.4	3.5 89	9.3 235	15 7	0.6	181	2.1	687					
2" 50	7.9 200	2.516 63.9	4.1 104	9.8 250	17 7.5	1.0	323	3.7	1223					
2 1/2" 65	10.6 270	3.047 77.4	5.1 129	10.6 270	20 9	1.5	504	5.8	1910					
3" 80	10.6 270	3.579 90.9	5.5 140	11.0 280	23 10.5	2.2	727	8.3	2751					
4" 100	10.6 270	4.682 118.9	6.3 160	11.8 300	24 11	4.0	1292	14.8	4892					

SPECIFICATIONS

Flow Range: 0.1 - 33 fps (0.03-10 m/s)

Sizes: 3/8" to 4" (10 to 100 mm)

Min. Conductivity: ≥ 0.5 micromhos/cm

Accuracy: ≥ 0.25% accuracy of rate from 1-33 fps.

≥ 0.5% accuracy of rate from .1-1 fps.

Electrode Material: Alloy C

Liner Material: PTFE

Max. Fluid Temperature: 311°F, (155°C)

Pressure Limits: 150 psi (10Bar)

Coil Power: Pulsed DC

Ambient Temperature: -4°F to 122°F, (-20°C to 50°C)

Meter Enclosure Material: Stainless Steel 316

End Connections: Tri-clamp (sizes 1"-4" per ISO 2852)

Junction Box Enclosure Protection: Stainless Steel, Nema 4X

Cable Entries: 1/2" NPT Cord Grip

Remote Amplifier Enclosure: NEMA 4



Please see our website at
www.badgermeter.com
 for specific regions and contacts.

Due to continuous research, product improvements and enhancements, Badger Meter reserves the right to change product or system specifications without notice, except to the extent an outstanding bid obligation exists.



BadgerMeter, Inc.

P.O. Box 245036, Milwaukee, WI 53224-9536

Telephone: (414) 355-0400 / (877) 243-1010

Fax: (414) 355-7499 / (866) 613-9305

www.badgermeter.com