

GENERAL

Badger's Primo amplifier was specifically designed to be used with the entire line of Magnetoflow electromagnetic flow meters. This amplifier represents the culmination of years of research into mag meter signal processing and includes the latest developments in microprocessor signal conditioning technology. The advanced design of the unit allows the accuracy of the detector to be better than .25% and the flow range better than 300:1. The Primo amplifier can be used as an integral part of the detector or it can be mounted remotely when necessary. The Primo electronics are housed in a NEMA 4X aluminum powder coated enclosure with easy access to all wiring and programming functions.

OPERATION

As the analog signal is received from the detector, the Primo unit amplifies the signal and converts it into digital information. At the processor level, the signal is analyzed through a series of sophisticated software algorithms and after separating it from electrical noise, it is converted into both analog and digital signals that are used to display rate of flow and totalization. In addition the processor controls zero-flow stability, analog and frequency outputs, serial communications and a variety of other parameters. Primo's 4 line, 16 character LCD display simultaneously indicates rate of flow, forward and reverse totalizers and diagnostic messages. It also serves to guide the user in simple English terms through the user-friendly programmable routines.

Programmable parameters of the Primo amplifier include: calibration factors, reset of totalizers, pulse value with auto decimal point position, selection of unit of measure, selection of flow direction, analog signal output, relay and open collector high and low flow alarm signals, low flow cut-off percent of flow and noise dampening factor.

APPLICATION

The Primo amplifier main function is to detect and condition the flow information from the electromagnetic detector. The unit is ideally suited for use in applications where the flow is continuous and indication of rate and totalization is required. Also, in applications where a minimum and/or a maximum flow rate must be kept and carefully monitored, the unit also provides pulse signals that can be fed to dedicated batch controllers, PLCs and other more specialized instrumentation.



Magnetoflow® Primo®

FEATURES

- Microprocessor based
- Large 4 line x 16 character back-lit LCD display
- User friendly programming procedure
- Digital and analog outputs
- NEMA 4X enclosure
- Sensor or remote wall mount
- Bidirectional flow sensing/totalization
- Automatic zero point stability
- Better than 0.1% repeatability
- Measures fluids with as low as 5.0 micromhos/cm conductivity
- Empty pipe detection



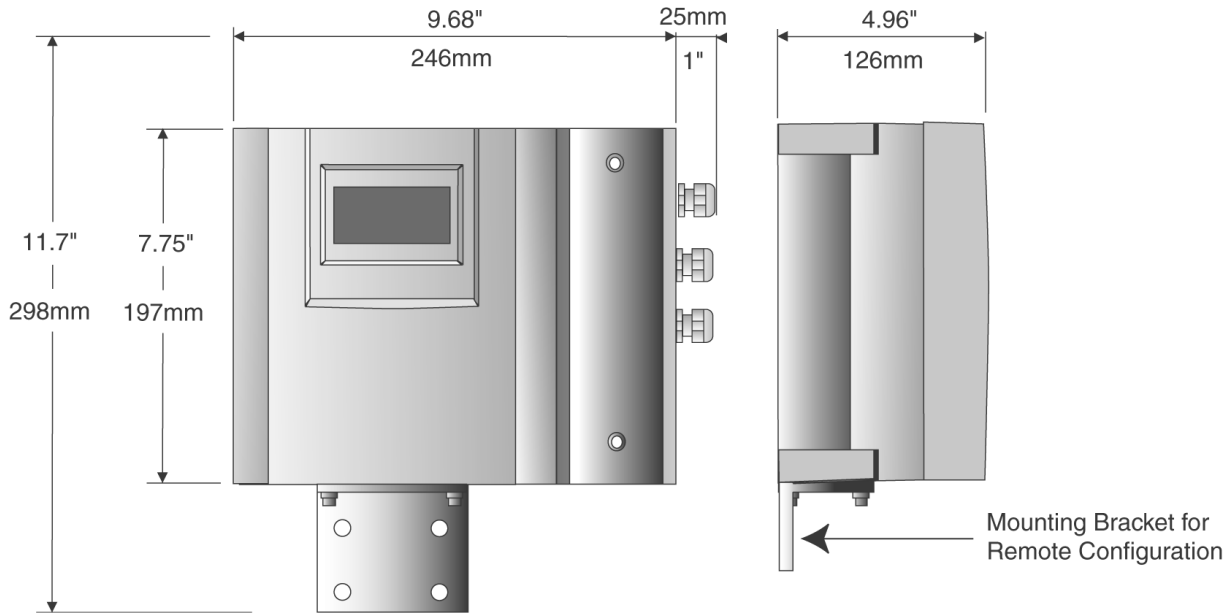

SPECIFICATIONS

Power Supply: 85-265 VAC, 45-65 Hz

Power Consumption: 20W

Accuracy: $\pm 0.25\%$ accuracy of rate from 1-39.4 fps.

$\pm 0.5\%$ accuracy of rate from .1-1 fps.

Repeatability: $<0.1\%$

Minimum Fluid Conductivity: 5.0 micromhos/cm

Processing: Microprocessor H8 (16 bit)

Flow Direction: Unidirectional or bidirectional, 2 separate totalizers (programmable)

Analog Outputs:

Current

4 - 20mA $< 800 \Omega$

2 - 10mA $< 800 \Omega$

0 - 20mA $< 800 \Omega$

0 - 10mA $< 800 \Omega$

Output Frequency: Scaled Pulse output (open collector), Max 5Khz

Digital Outputs:

Voltage sourcing transistor, 24VDC, 100mA max

(3) AC Solid state relays, 48VAC, 0.5 amp max

Outputs: All outputs are short circuit safe.

Noise Dampening: Programmable from 1 to 6

Pulse Width: Programmable from 5ms to 500ms

Min-Max Flow Alarm: Programmable relay outputs 0 to 100% of flow

Units of Measure: Gallons, Ounces, Pounds, MGD, Liters, Cubic Meters, Cubic Feet, Acre Feet

Galvanic Separation: ≈ 500 volts

Low-flow-cutoff : Programmable 0-10% of max flow

Zero-point Stability: Automatic correction

LCD Display: 4 lines x 16 character back-lit alphanumeric;

Displays (2) Totalizers, Flow Rate, Alarm Conditions

Programming: Three button manual

Housing: Cast aluminum, powder coated paint

Housing Rating: NEMA 4X

Mounting: Detector mount or remote wall mount (bracket supplied)

Cable Connection: 1/2" NPT Cord Grip

Ambient Temperature: -4 to 140° F (-20 to 60° C)

Serial Communication: RS232

Please see our website at
www.badgermeter.com
 for specific contacts.

Due to continuous research, product improvements and enhancements, Badger Meter reserves the right to change product or system specifications without notice, except to the extent an outstanding bid obligation exists.



BadgerMeter, Inc.

P.O. Box 245036, Milwaukee, WI 53224-9536

Telephone: (414) 355-0400 / (877) 243-1010

Fax: (414) 355-7499 / (866) 613-9305

www.badgermeter.com