

Type 859

**1/4", 1/2", 3/4" and 1"
Cooling Fin Valve Assembly
RESEARCH CONTROL® Valves**

**Technical
Brief**

DESCRIPTION

The Type 859 globe control valve with cooling fin bonnet is available in 1/4", 1/2", 3/4" and 1" sizes. It is designed for modulating flow control in industrial applications at 400 to 700 degrees F. at pressures less than 5000 psi (dependent on body and packing material). The added bonnet length and fins serve to reduce the heat at the packing area. This allows the standard CV ring packing to be used at higher process temperatures than could normally be tolerated with the standard valve.

APPLICATIONS

The Type 859 valve is widely used in high temperature applications where steam, hot water, hot hydraulic oil or other fluids or gases must be controlled precisely through 1/4", 1/2", 3/4" or 1" lines. Extended cooling fin valves are available for applications that exceed 700 degrees F.

⚠ CAUTION

The appropriate pressure/temperature rating literature of not only the body material but also the packing should be consulted during the selection process. This information is available in the catalog or from the factory.

MATERIALS OF CONSTRUCTION

Body-Bonnet

Standard 316 stainless steel, carbon steel (WCB)
Optional Monel®, alloy 20, Hastelloy® C and B or ASTM equivalent

Innervalue

Standard 316 stainless steel
Optional Stellite®, Monel, alloy 20, Hastelloy C and B or ASTM equivalent

Packing

Standard TFE chevron rings
Optional Graphite

Actuator

Standard Die cast aluminum
Optional 316L stainless steel on standard 1/2" models

ACTUATOR CHOICES

Standard Air-to-open, fail close
Air-to-close, fail open
Optional With integral top mounted positioner

Standard Signals 3-15#, 3-27#, 6-30#
Optional Signals 3-9#, 9-15#, with positioner

Accessories Filter regulator, gauges, I/P converter, limit switches, handwheel, solenoids



Shown with Type 754 Actuator

STANDARD FEATURES

- Wide range of interchangeable trim sets
- Threaded bonnet for quick disassembly
- Choice of linear or equal percent on "J" trim and larger
- TFE chevron packing
- ANSI Class III shutoff

OPTIONAL FEATURES

- Flanges, socket weld and butt-weld nipples
- Angle pattern body
- Graphite packing

Hastelloy® is a registered trademark of The Haynes Stellite Company.

Monel® is a registered trademark of Inco Alloys International, Inc.

RESEARCH CONTROL® is a registered trademark of Badger Meter, Inc.

Stellite® is a registered trademark of The Haynes Stellite Company.



BadgerMeter, Inc.

940898

6-04

1/4" RESEARCH CONTROL® Valve

Pressure vs. Temperature Rating for Valve Superstructure Excluding Packing or End Fittings (See Note 1 below)

Temp	316 S/S	Carbon Steel	Hast B or =	Hast. C or =	Monel	Alloy 20
100°F	5000	4000	5000	5000	4000	5000
200°F	5000	3700	5000	5000	4000	5000
300°F	4750	3500	5000	5000	3880	4850
400°F	4190	3200	5000	5000	3770	4700
500°F	4000	2900	4900	4900	3740	4500
600°F	3820	2600	4850	4850	3740	4200
700°F	3640	2300	4800	4800	3640	3900
800°F	3580		4750	4750	3580	3700
900°F	2840			4500	2280	3000
1000°F	1160			4000	940	1500
1100°F	Consult factory for higher temperatures			3500		
1200°F	Consult factory for higher temperatures			3000		
Rec. Torque ft/lb (+/- 2ft/lb)	37	37	39	37	31	35

1/2" RESEARCH CONTROL® Valve

Pressure vs. Temperature Rating for Valve Superstructure Excluding Packing or End Fittings (See Note 1 below)

Temp	316 S/S	Carbon Steel	Hast B or =	Hast. C or =	Monel	Alloy 20
100°F	5000	4000	5000	5000	4000	5000
200°F	4750	3800	5000	5000	3780	5000
300°F	4310	3600	5000	5000	3520	4950
400°F	3860	3300	5000	5000	3420	4850
500°F	3640	3100	4900	4900	3390	4600
600°F	3470	2900	4870	4870	3390	4300
700°F	3310	2700	4610	4610	3310	4200
800°F	3255		4430	4430	2090	4000
900°F	3190			4200	2070	3000
1000°F	1860			4000	850	1500
1100°F	Consult factory for higher temperatures			3400		
1200°F	Consult factory for higher temperatures			3000		
Rec. Torque ft/lb (+/- 2ft/lb)	122	122	131	124	102	117

3/4" and 1" RESEARCH CONTROL® Valve

Pressure vs. Temperature Rating for Valve Superstructure Excluding Packing or End Fittings (See Note 1 below)

Temp	316 S/S		Carbon Steel	
	3/4"	1"	3/4"	1"
100°F	1500	1500	1500	1500
200°F	1450	1450	1350	1350
300°F	1325	1325	1325	1325
400°F	1175	1175	1275	1275
500°F	1100	1100	1200	1200
600°F	1070	675	1100	1100
700°F	840	250	1075	1075
800°F	575			4430
3/4" and 1" Rec. Torque = 290 ft/lbs.				

Note 1. The pressure/temperature ratings listed above are based on material cross sections at the joint between the body and bonnet where a gasketed screwed type bonnet is utilized. When the proper torque levels are used, the valve should not experience rupture of the joint or the material. The above listed torque levels were used in hydrostatic tests at the factory at 70 degrees F. at maximum body rating and were found to provide acceptable seating. Other factors such as high or cyclic temperatures, light process gases, or poor gasket surfaces can dictate the ability of a seal to be made. Under such conditions, the only way to be assured of tight sealing is to perform a test under the actual process conditions.

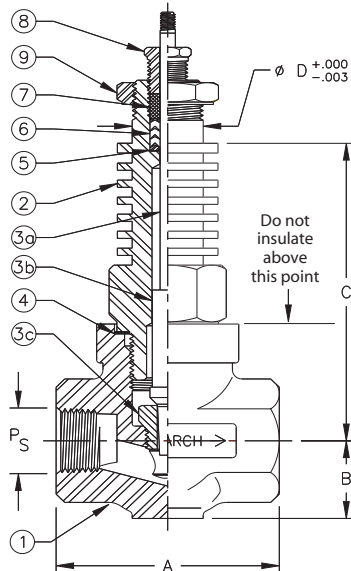

Description of Items

- Valve Body (Investment cast, NPT ends)
- Valve Bonnet: 1/4" = 7/8" hex; 1/2" = 1-1/4" hex; 3/4" = 1-1/2" hex; 1" = 1-3/4" hex. (Some exotic materials may use round material.)
- Innervalve (trim set)
 - Plug
 - Stem: 1/4" = 1/8" Ø; 1/2" = 3/16" Ø; 3/4" = 3/16" Ø; 1" = 3/16" Ø
 - Seat: 1/4" = 3/8" hex; 1/2" = 5/8" hex; 3/4" = 3/4" hex; 1" = 15/16" hex
- Body Bonnet Gasket (may not be supplied in exotic material)
- Packing Adaptor (CV ring packing only)
- Packing (CV ring)
- Packing Follower (CV ring packing only)
- Packing Gland: 1/4" = 7/16" hex; 1/2" = 1/2" hex; 3/4" = 1/2" hex; 1" = 1/2" hex
- Yoke Lock Nut: 1/4" = 7/8" hex; 1/2" = 1-1/8" hex; 3/4" = 1-1/8" hex; 1" = 1-1/8" hex
- Stem connector: 1/4" = 1/4" hex; 1/2" = 3/8" hex; 3/4" = 3/8" hex; 1" = 3/8" hex
- Upper Stem

DIMENSIONS (inches)

PS	A	B	C	D	STROKE
1/4 inch	2.12	0.68	2.56	0.625	0.437
1/2 inch	2.75	1.00	3.83	0.875	0.562
3/4 inch	3.37	1.18	3.90	0.875	0.562
1 inch	4.00	1.50	3.95	0.875	0.562

INNERVALVE CHART

Valve Size	Trim Designation	Max Cv	Orifice Dia. (in)	Orifice Area(sq in)	Nominal Linear	Rangeability Equal %
1"	6.0	6.0	0.6250	0.3068	50:1	60:1
1"	5.0	5.0	0.6250	0.3068	50:1	60:1
1"	4.5	4.5	0.5000	0.1963	50:1	60:1
3/4"-1"	4.0	4.0	0.5000	0.1963	50:1	60:1
3/4"-1"	3.5	3.5	0.5000	0.1963	50:1	60:1
1/2"-1"	A	2.5	0.3750	0.1104	40:1	50:1
1/2"-1"	B	2.0	0.3750	0.1104	40:1	50:1
1/2"-1"	C	1.25	0.2810	0.0620	40:1	50:1
1/2"-1"	D	0.8	0.2500	0.0491	40:1	50:1
1/2"-1"	E	0.5	0.2500	0.0491	40:1	50:1
1/4"-1"	F	0.32	0.1560	0.0191	30:1	40:1
1/4"-1"	G	0.2	0.1560	0.0191	30:1	40:1
1/4"-1"	H	0.13	0.1560	0.0191	30:1	40:1
1/4"-1"	I	0.08	0.1560	0.0191	30:1	40:1
1/4"-1"	J	0.05	0.1560	0.0191	30:1	40:1
1/4"-1"	K	0.03	0.0860	0.0058	25:1	NA
1/4"-1"	L	0.02	0.0860	0.0058	25:1	NA
1/4"-1"	M	0.01	0.0860	0.0058	25:1	NA
1/4"-1"	N	0.006	0.0860	0.0058	25:1	NA
1/4"-1"	O	0.003	0.0860	0.0058	25:1	NA
1/4"-1/2"	P1	0.002	0.0625	0.0031	15:1	NA
1/4"-1/2"	P2	0.0013	0.0625	0.0031	15:1	NA
1/4"-1/2"	P3	0.001	0.0625	0.0031	15:1	NA
1/4"-1/2"	P4	0.0006	0.0625	0.0031	15:1	NA
1/4"-1/2"	P5	0.0004	0.0625	0.0031	15:1	NA
1/4"-1/2"	P6	0.00027	0.0625	0.0031	15:1	NA
1/4"-1/2"	P7	0.00018	0.0625	0.0031	15:1	NA
1/4"-1/2"	P8	0.00012	0.0625	0.0031	15:1	NA
1/4"-1/2"	P9	0.00008	0.0625	0.0031	15:1	NA
1/4"	P10	0.00005	0.0420	0.0014	15:1	NA
1/4"	P11	0.000036	0.0420	0.0014	15:1	NA
1/4"	P12	0.000024	0.0420	0.0014	15:1	NA
1/4"	P13	0.000016	0.0420	0.0014	15:1	NA
1/4"	P14	0.00001	0.0420	0.0014	15:1	NA
1/4"	P15	0.000006	0.0420	0.0014	15:1	NA
1/4"	P16	0.000004	0.0420	0.0014	15:1	NA
1/4"	P17	0.0000027	0.0420	0.0014	15:1	NA
1/4"	P18	0.0000018	0.0420	0.0014	15:1	NA

Note: "K" through "O" and the "P" series trims are considered reduced trims when installed in a 1/2" valve. Occasionally "P1" through "P9" trims are made on a .042" orifice.

Due to continuous research, product improvements and enhancements, Badger Meter reserves the right to change product or system specifications without notice, except to the extent an outstanding bid obligation exists.

Please see our website at
www.badgermeter.com
 for specific contacts.



BadgerMeter, Inc.

P.O. Box 581390, Tulsa, Oklahoma 74158
 (918) 836-8411 / Fax: (918) 832-9962

www.badgermeter.com