



***IMPORTANT: Read this manual before  
attempting any installation, wiring or operation.***



## SCOPE OF THE MANUAL

This manual contains information concerning the installation, operation and maintenance of the Badger® *MEASURE RITE*® truck meter. To ensure efficient operation of the meters, the instructions given in this manual should be thoroughly read and understood. Retail the manual in a location where it is readily available for reference.

### MATERIALS:

Meter Body: Bronze  
Impeller: 316SST  
Shaft: Tungsten Carbide  
Bearings: UHMWPE  
Electronics Housing: Coated Aluminum (Polyurethane - Enamel)  
Window: Tempered Glass (with anti-fog coating)

### PRESSURE RATING:

400 PSIG (B16.15 CL250) at 150 ° F  
Consult factory for higher temperatures.

### METER SIZE & FLOW RANGE:

¾" NPT: 5-30 GPM  
1" NPT: 15-60 GPM  
1¼": 15-90 GPM  
1½" NPT: 21-125 GPM

2" NPT: 35-200 GPM

### ACCURACY:

+/- 1% or better (within flow range)

### OPTIONS:

Mounting Bracket  
Ball Valve (mount 6" downstream of meter)  
Upstream Strainer (60 Mesh recommended at least 12" upstream of valve)

## INTRODUCTION

### DESCRIPTION

The Badger *MEASURE RITE*® volumetric truck meter is designed specifically for measuring and dispensing water for premixed batches at the job site. This rugged, truck mount unit will accurately totalize the amount of water added, depending on slump requirements.

### UNPACKING AND INSPECTION

To avoid damage in transit, *MEASURE RITE* truck meters are shipped to the customer in special shipping containers.

**NOTE:** If damage to a shipping container is evident upon receipt of a meter, request the carrier to be present when the meter is unpacked.

Retain the container and all packing material for possible use in reshipment or storage. Visually inspect the meter and applicable accessory device for any physical damage. If damage is found, immediately notify carrier for insurance purposes.

## INSTALLATION

### PLUMBING

Meter should be plumbed into the existing pipe running from the water storage tank to the drum access funnel. Sensor tee end fittings should be mated with a compatible NPT external thread. The use of Teflon® tape or pipe dope is recommended to maintain a proper seal.

**NOTE:** We recommend 6-12" if straight pipe upstream of the meter and 6" downstream. In addition, a strainer upstream is recommended (see options above.)

### WIRING

The wiring necessary is the connection of the meter input power to the truck accessory power supply.

Although the voltages are considered "low DC voltage," a licensed electrician is recommended.

The wiring does not have to be in conduit but is recommended to provide mechanical protection. Splices can be made with wire nuts or other suitable connectors, but should be water tight to avoid corrosion of the connections that could lead to a malfunction.

## FUNCTIONS

### DISPLAY AND PUSHBUTTON FUNCTION

The LCD display uses an 8-digit SDI display with the upper digit masked off. The standard display is a 4-digit totalizer with the following format:

##.##

The units of measure displayed are gallons with a resolution of 1/100 gallon or 1.3 ounces.

At power up, the meter will be in the Totalizer Mode. In this mode, four digits are active plus the decimal point and Tot Gal-Mode indicator is on and Cal lbs is off.

### TOTALIZER MODE

The totalizer will indicate volume in 1/100 gallon increments when the flow is started. At the end of the batch, the totalizer can be reset with the pushbutton by pressing and releasing it within a minimum of 0.5 seconds and a maximum of 2 seconds.

### CALIBRATION MODE

Starting from a reset condition in the Totalizer Mode, run flow through the meter until approximately 25 gallons are indicated. This volume should be weighed using a platform scale.

Press and release the pushbutton for at least 5 seconds. After a brief delay of approximately 1-2 seconds, a five-digit number is displayed. This represents the weight of the previously displayed total in pounds, with a resolution of 0.01 lbs. In this mode Tot Gal is off and Cal lbs is on. When first entering the Calibration Mode the first digit will be flashing.

At this point, the actual weight taken from the scale and the indicated weight are compared. If they are within 1% no correction is needed and you can exit the calibration mode by scrolling until no digits are flashing and hold the pushbutton for a minimum of 2 seconds or simply wait 2 seconds until the meter automatically defaults to Totalizer Mode.

If the scale reading and meter are out of correlation, then the scale reading should be programmed into the meter using the following procedure.

**NOTE:** If you want to calibrate the meter in liters, take the actual scale reading, multiplied by 3.785 and program this value into the meter.

To make a correction to the weight reading, move the flashing digit to the appropriate location and make the correction by pressing and holding the pushbutton.

To move the flashing digit press and release the pushbutton within a minimum of 0.5 seconds and a maximum of 2 seconds. The next preceding digit should begin flashing. When moving from the most significant digit you will note none of the digits are flashing. If you have completed the correction, press and hold the pushbutton for a minimum of 5 seconds. This will recalculate the internal scaling factor for the totalizer and return the meter to the Totalizer Mode. If you need to further correct another digit press and release the pushbutton within a minimum of 0.5 seconds and a maximum of 2 seconds. The least significant digit should now begin to flash.

When the appropriate digit is flashing and you wish to make a correction, press and hold the pushbutton. The digit will begin incrementing at approximately a 1-2 seconds rate. When the desired value is reached release the pushbutton. The preceding digit will now begin flashing.

**NOTE:** If in the Calibration Mode, and the pushbutton has not been pressed for at least 60 seconds, the meter will revert back to the Totalizer Mode without computing a new totalizer scaling factor.

## MOUNTING

### MOUNTING A Badger® MEASURE RITE® FLOW TOTALIZING METER ON A CEMENT TRUCK



#### READ THROUGH BEFORE STARTING!

For the best mounting location, the meter should be mounted on the ladder platform, just upstream of (and in-line with) the water manifold. Verify that any movement of the platform will not cause the meter to contact the barrel or other truck components.

#### The following are the steps in the mounting procedure:

- Release all pressure in the system.
- Disconnect the standard rubber hose from the inlet of the existing water manifold.
- Install a hose adapter into the outlet of the meter.
- Always use pipe dope or Teflon® Tape on NPT threads.
- Install a (6" minimum) pipe nipple into the inlet of the meter.
- Install a 60 mesh strainer to the end of the pipe nipple.
- Install a hose adapter into the inlet of the strainer.
- Using a short section of rubber hose, connect the outlet of the meter to the manifold. The hose should be kept as straight as possible.
- Locate the two U-Bolts on the meter as shown, and drill through the deck plate.
- Install lock washers and nuts included with our product. The "flats" on the hex ends of the meter should keep the unit upright.
- Test for leakage (fill in with liquid and keep pressurized.)

#### NOTE:

- To align the outlet fitting with the fitting of the manifold, several washers may be installed under the manifold base to raise it. Longer screws may be required.
- Use hose clamps on all rubber hose connections.

#### Wiring:

- Connect the meter wires to a constant DC supply voltage of 9-32 volts. (Red +, Black -)
- Seal any splices.

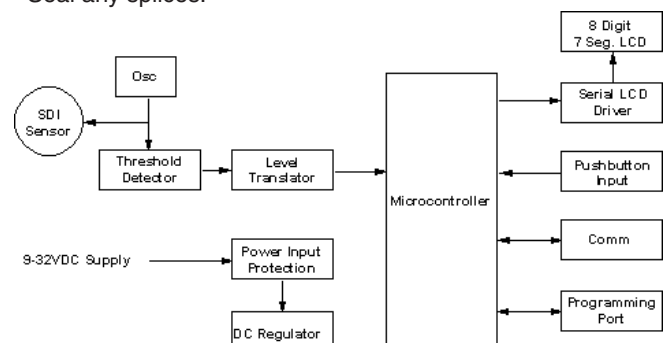

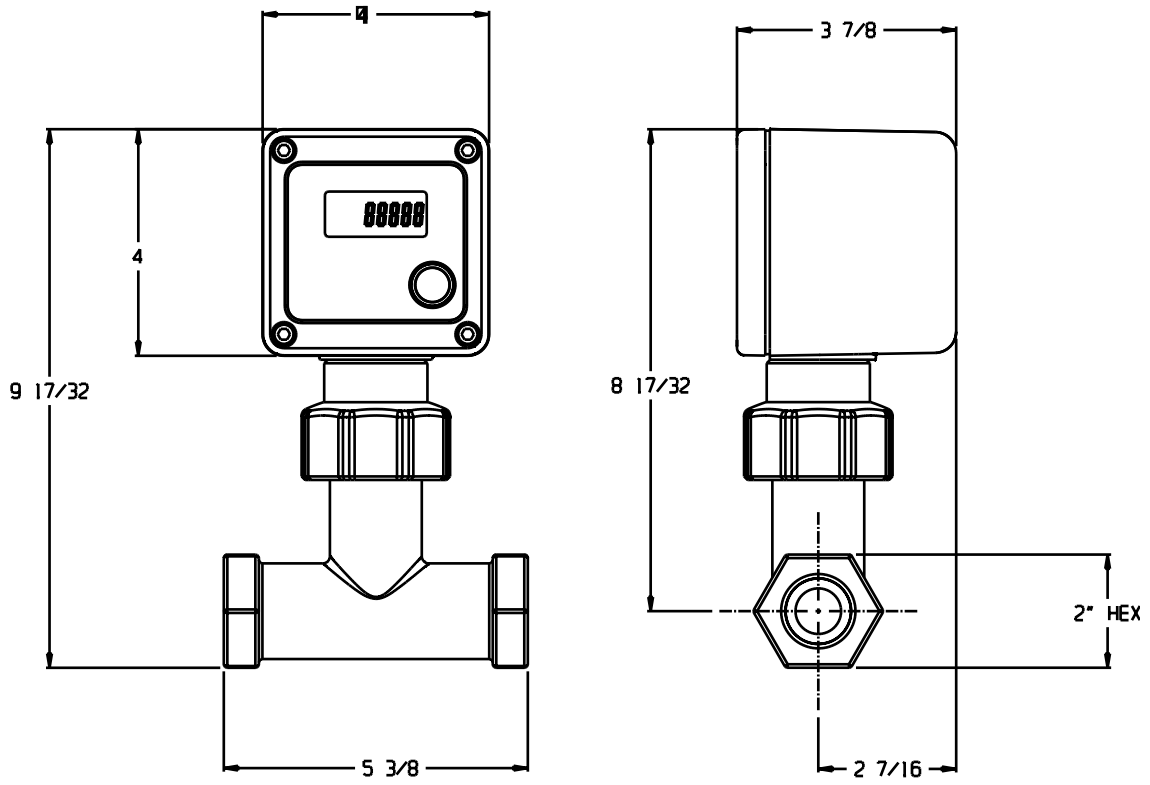

(3/4" & 1" NPT PIPE SIZES)

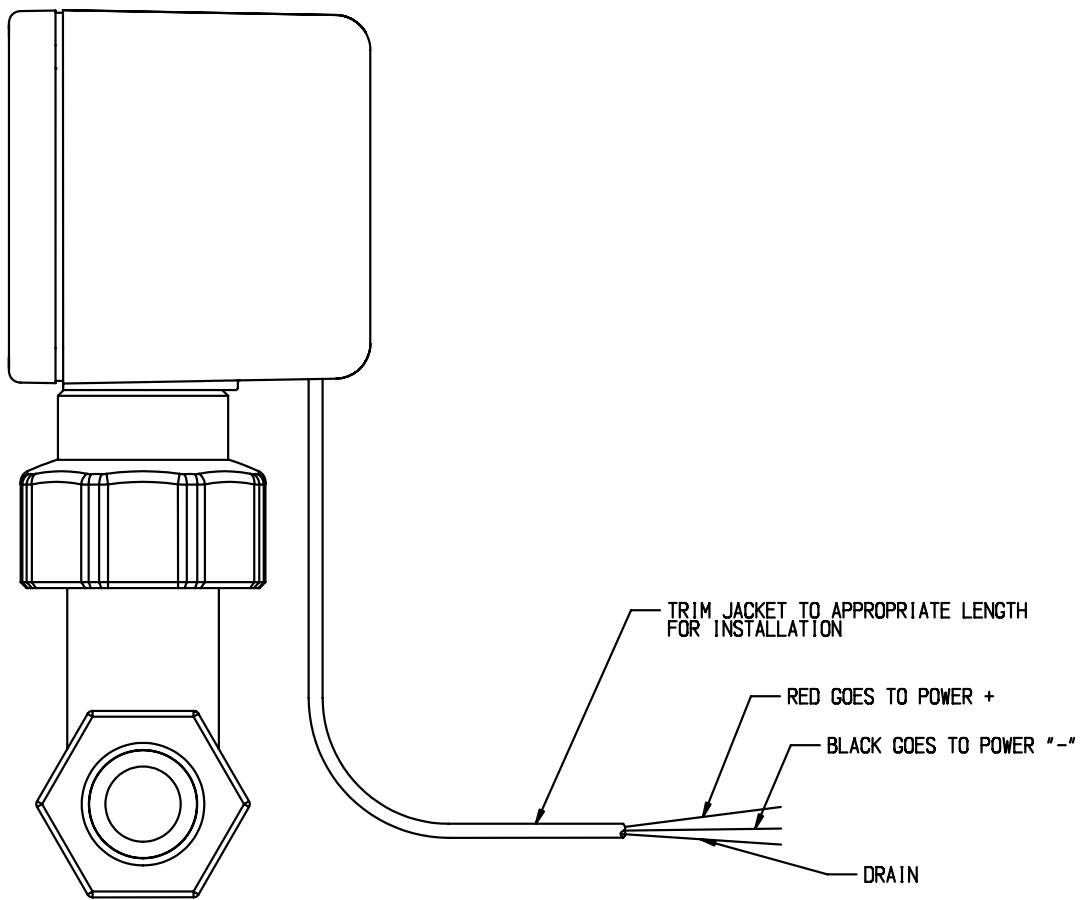

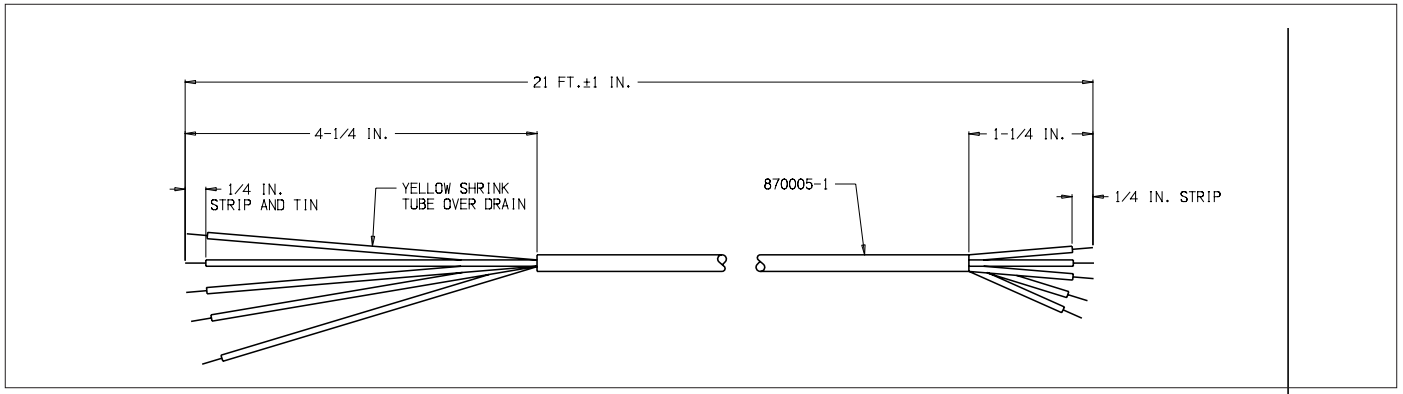

## Badger® MEASURE RITE® MR-1P Scaled Pulse Output

### SCALED PULSE OUTPUT OPTION

This option will generate a scaled output pulse on the two additional wires in the cable. See the following specification for the output pulse:

- 1 pulse equals 0.1gallon
- Nominal 1msec pulse width
- Can be used as a current sink or source output
- Output is rated 0-60V (1A AC) or (2A DC)

See wiring diagram below.

### MR-1P Scaled Output Wiring Diagram

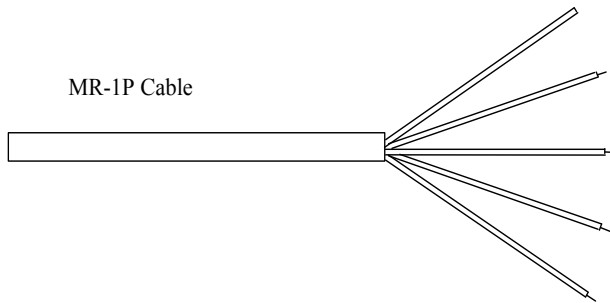

### User Connections

Drain

Red (Power +9-32VDC @ 1mA)

Black (Power GND)

White (Isolated Scaled Pulse Out +)

Green (Isolated Scaled Pulse Out -)

Scaled Pulse Output  
Electrical Rating

0-60V (DC or AC) @ 100mA

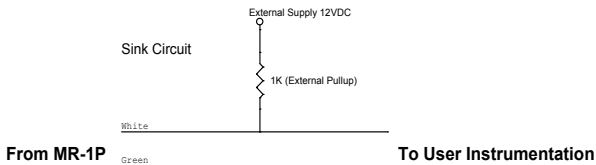
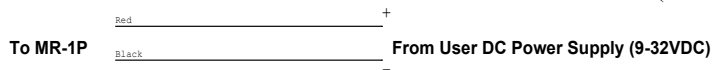

Or

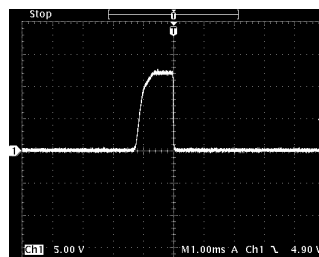
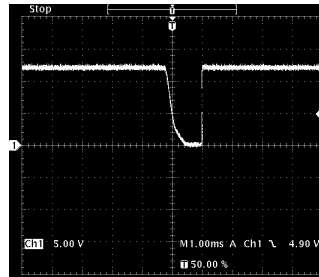
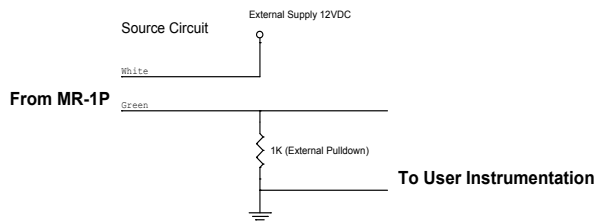

*(This page intentionally left blank)*

*(This page intentionally left blank)*

Badger® and MEASURE RITE® are registered trademarks of Badger Meter, Inc.  
TORLON® is a registered trademark of Amoco Chemicals Corporation.  
Teflon® is a registered trademark of E.I. du Pont de Nemours and Company.

---

Please see our website at  
**[www.badgermeter.com](http://www.badgermeter.com)**  
for specific contacts.

Copyright © Badger Meter, Inc. 2009. All rights reserved.

Due to continuous research, product improvements and enhancements, Badger Meter reserves the right to change product or system specifications without notice, except to the extent an outstanding contractual obligation exists.



**BadgerMeter, Inc.**

6116 East 15th Street, Tulsa, OK 74112

Telephone: (800) 364-9876 / Fax: (918) 832-9962

[www.badgermeter.com](http://www.badgermeter.com)