

DESCRIPTION

The model MS-E1 is a pulse transmitter, designed to be used with Badger's Turbo flow meters. The pulse transmitter provides a scaled electrical pulse signal (switch closure type) for each discrete unit of liquid volume metered. The signal is used to operate instruments and controls.

Because of the simplicity of this transmitter, maintenance procedures are minimized, furthermore, the enclosure provides watertight protection and is designed to explosion-proof specifications.

The model MS-ER1 adds a six-digit, non-reset totalizing register which provides flow totalization in addition to the pulse output. The mechanical register will totalize under no-power conditions.

OPERATION

Motion of the flow meter measuring element is transferred to the transmitter by means of an output spindle. The spindle provides mechanical movement to a gear train designed to rotate a four-pole permanent magnet. As the magnet turns, the magnetic field causes a glass-enclosed reed switch to open and close, generating a pulse output.

By selecting different calculated gear train and driver-to-driven change gear ratios, a wide variety of pulse output rates are available.

On the MS-ER1 model, the gear train drive spindle in the transmitter is geared to the input spindle of the register to totalize flow. This versatile transmitter/register is available with a wide choice of pulse rates for measuring in gallons, liters or pounds.

APPLICATIONS

The pulse output of the MS-E1 and MS-ER1 pulse transmitters is used with electromechanical or electronic counters and batch controllers that do not provide scaling capabilities.

Typical applications include liquid feeding, blending and batch control.



**MS-E1 Pulse Transmitter (Front)
MS-ER1 Transmitter / Register (Back)**

FEATURES

- Operates with direct AC or DC supply
- Glass sealed reed switch, single-pole, single-throw
- Easy recalibration with change gears
- Rugged anodized aluminum enclosure
- Explosion-proof design meets NEC codes (MS-E1)
- NEMA 4 environment protection (watertight)
- Six-digit, non-reset totalizer (MS-ER1)

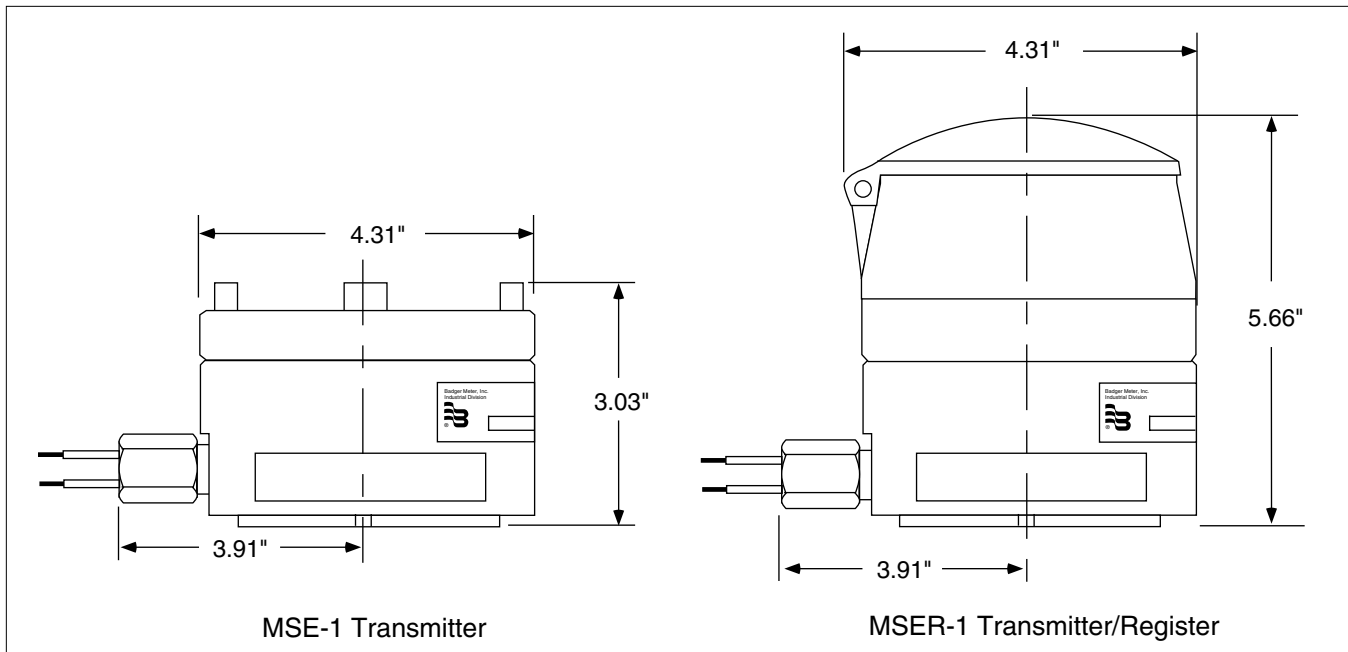

Dimensional Drawings

SPECIFICATIONS

Transmitter

- Switch Rating – 120 Volts Max., 0.5 Amp Max.
- Reed Switch – Single-pole, single-throw
- Explosion-proof Enclosure – Meets N.E.C. codes (MS-E1)
- Operating Temperature – To 250° F

Dimensions (MS-E1)

- Height – 3.03"
- Width – 4.31"
- Width with Conduit Fitting – 6.07"

Register (MS-ER1)

- Register – Straight reading, six-digit, non-reset totalizer
- Operating Temperature – To 250° F

Dimensions (MS-ER1)

- Height – 5.66"
- Width – 4.31"

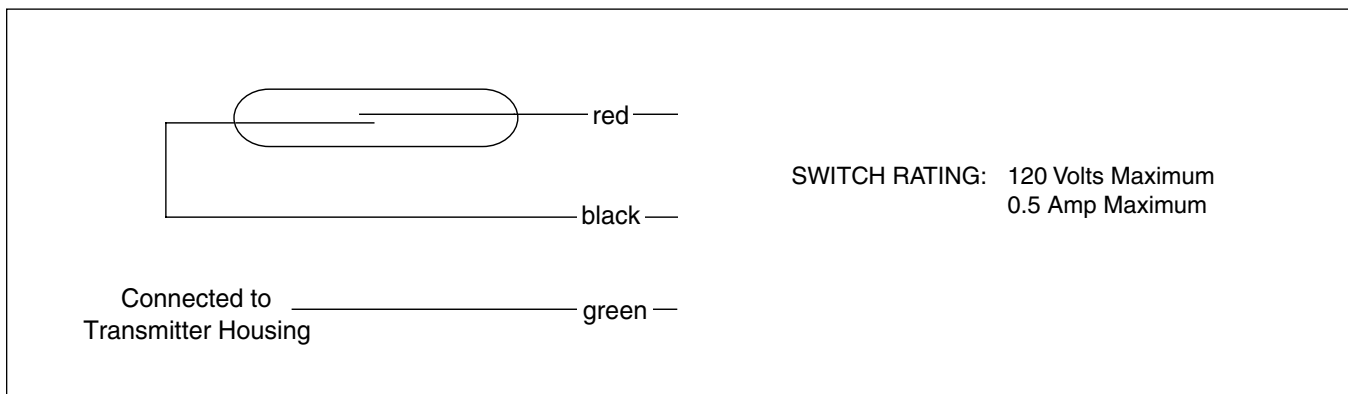

MS-E1 & MS-ER1 Transmitter Wiring Diagram



Please see our website at
www.badgermeter.com
for specific contacts.



Badger Meter, Inc.

P.O. Box 245036, Milwaukee, WI 53224-9536
Telephone: (414) 355-0400 / (800) 456-5023
Fax: (414) 355-7499 / (866) 613-9305
www.badgermeter.com