

# Series 500

## Analog Transmitters

by Data Industrial

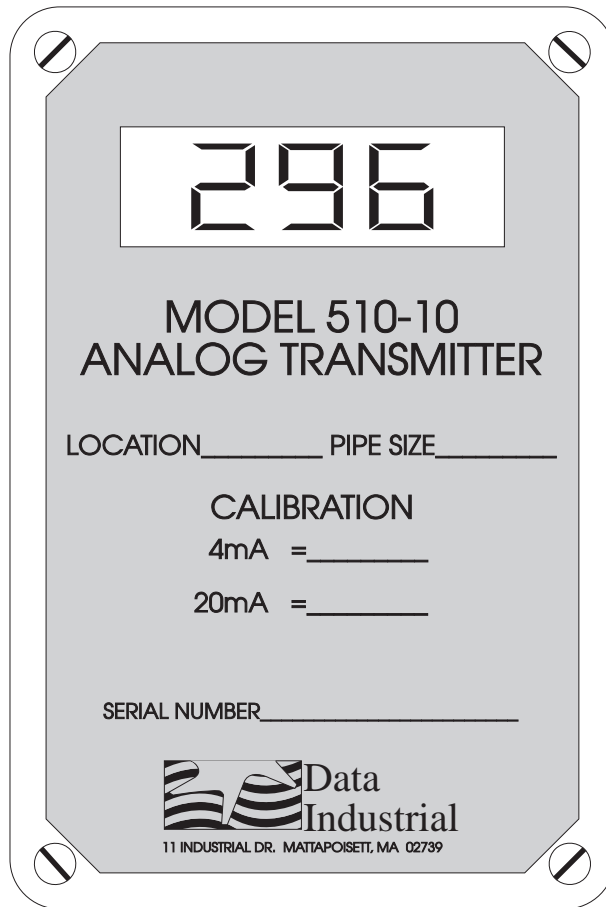

# Owner's Manual



2/95  
PN 72806

# Table of Contents

Introduction .....	1
4-20 mA Loop Supply Requirements .....	2
Installation .....	3
Electrical Wiring for 500/550 .....	4
Electrical Wiring for 510-10 .....	5
Calibration of Transmitter .....	6
510-10 Display Board Calibration .....	7
Specifications .....	9
Warranty .....	10

All rights reserved. No part of this work covered by the copyrights hereon may be reproduced or copied in any form or by any means - graphic, electronic, or mechanical, including photocopying, recording, taping, or information and retrieval systems - without written permission of Data Industrial.

Copyright © 1995  
Data Industrial Corporation  
11 Industrial Drive  
Mattapoisett, MA 02739  
508-758-6390  
FAX: 508-758-4057

## Introduction

The Series 500 Analog Transmitter is a 4-20mA current, loop-powered converter for use with all Data Industrial non-magnetic flow sensors. The transmitter is equipped with an on-board calibration frequency source and two frequency span ranges, allowing the unit to be field-calibrated to provide high resolution for your specific flow ranges.

The Series 500 is contained in a weatherproof box. It can be used either in conjunction with all Data Industrial flow monitors, or independently when only an analog signal is required to interface with data acquisition systems or control devices. The figure below shows the Series 500's loop relationship with other possible components in a system.

**Figure 1: Loop Relationships**

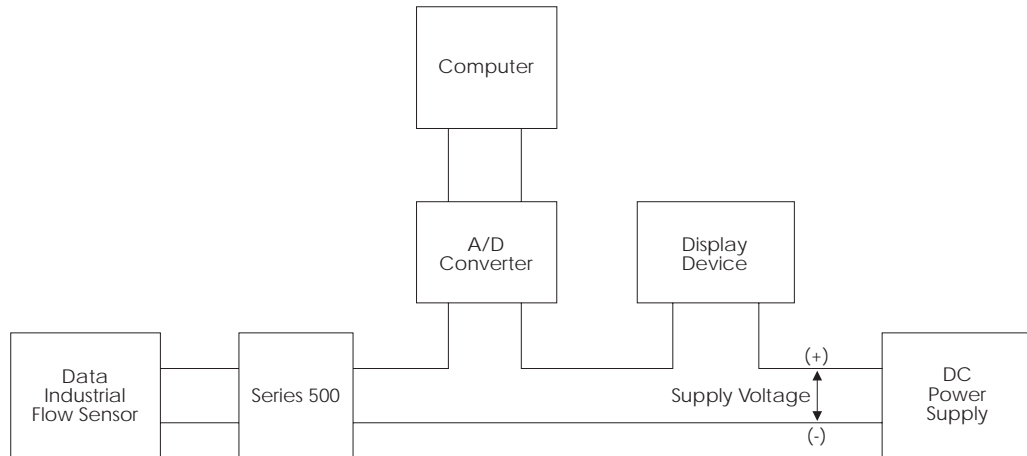

**Note:** The Series 500 has a non-isolated output. Be careful when sharing sensors or power supplies with other equipment.

## Models

### **Model 500-10**

This unit is a 4-20mA loop powered analog transmitter in a NEMA 4X enclosure.

### **Model 510-10**

This unit is a 4-20mA loop powered analog transmitter with a 3½ Digit LCD display in a NEMA 4x enclosure.

### **Model 550-10**

This unit is a 4-20mA loop powered analog transmitter board.



# Installation

## Mechanical

The enclosure may be mounted in two ways, as follows:

### **To locate up to 500 feet away from the sensor and surface mount on a flat surface**

1. Remove cover by turning the four captive fasteners  $\frac{1}{4}$  turn counterclockwise.
2. Mount the enclosure, using four number 6 pan head or number 8 round head machine, sheet metal, or wood screws.
3. Attach 1/2" conduit connectors through the holes provided.

### **To mount on top of the sensor**

1. Remove cover by turning the four captive fasteners  $\frac{1}{4}$  turn counterclockwise.
2. Remove the plastic thread protector from the flow sensor positioning collar and cable.
3. Insert the cable from the flow sensor through a 1/2" NPT close pipe nipple and screw the nipple into the top of the sensor positioning collar.
4. Attach 1/2" conduit connectors through the holes in the enclosure box. Screw the pipe nipple into the lower conduit connection.

Figure 3 for Electrical Installation for 500/550

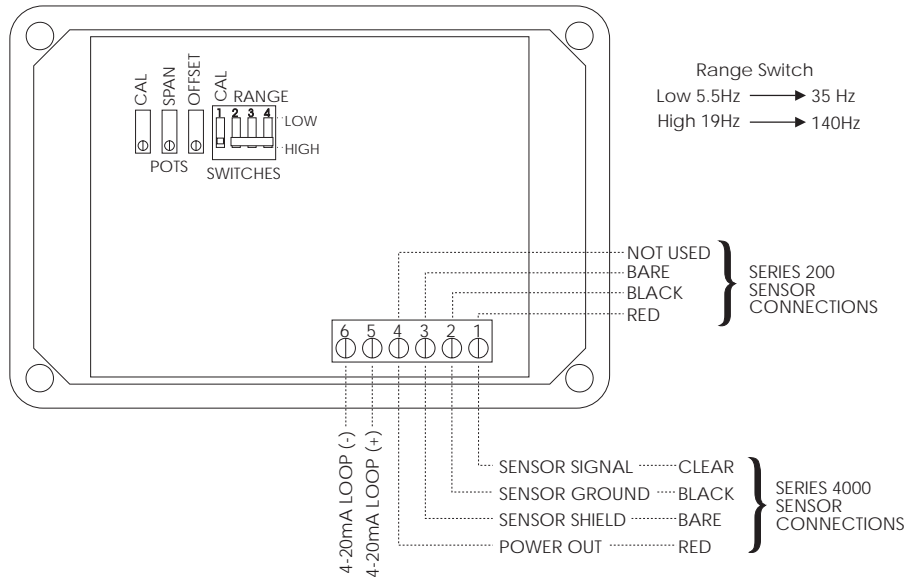

## Electrical Wiring for 500/550

Loop Power must be off and all wiring should be done before turning on loop power. The output of the device is not isolated from sensor input terminals. Be particularly careful if the sensor is to be shared with other Data Industrial equipment such as Models 1000, 800, or 600.

1. Remove cover from box by turning the four captive fasteners counterclockwise.
2. Refer to Figure 3 above for terminal connections.
3. Connect loop power supply positive (+) to terminal 5
4. Connect terminal 6 of Model 500/550 to positive analog terminal of input device (Chart Recorder, PLC, etc..)
5. Connect negative analog terminal of input device to loop power supply negative .
6. If you are installing a Series 200 sensor connect the red wire (signal) to terminal 1, black wire (ground) to terminal 2 and the shield to terminal 3 (Disregard shield for the IR sensors). If the sensor is not a Series 200, then go to step 7.
7. If you are installing a Series 4000 sensor connect the clear wire (signal) to terminal 1, black wire (ground) to terminal 2, shield wire to terminal 3, and red wire (power) to terminal 4.
8. Electrical installation is now complete.
9. Reinstall cover and ensure that all connections are tight and correctly aligned.

**Figure 4 for Electrical Installation for 510**

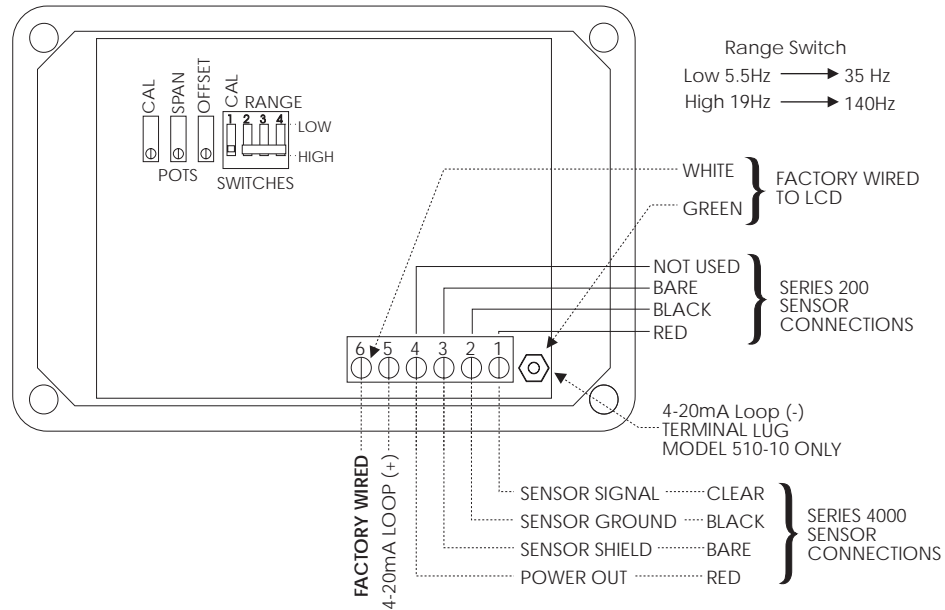

## Electrical Wiring for 510

Loop Power must be off and all wiring should be done before turning on loop power. The output of the device is not isolated from sensor input terminals. Be particularly careful if the sensor is to be shared with other Data Industrial equipment such as Models 1000, 800, or 600.

1. Remove cover from box by turning the four captive fasteners counterclockwise.
2. Refer to Figure 4 above for terminal connections.
3. Connect loop power supply positive (+) to terminal 5
4. Connect terminal Lug of Model 510 to positive analog terminal of input device (Chart Recorder, PLC, etc..)
5. Connect negative analog terminal of input device to loop power supply negative .
6. If you are installing a Series 200 sensor then connect the red wire (signal) to terminal 1, black wire (ground) to terminal 2 and the shield to terminal 3 (Disregard shield for the IR sensors). If the sensor is not a Series 200 the go to step 7.
7. If you are installing a Series 4000 sensor connect the clear wire (signal) to terminal 1, black wire (ground) to terminal 2, shield wire to terminal 3, and red wire (power) to terminal 4.
8. Electrical installation is now complete.
9. Reinstall cover and ensure that all connections are tight and correctly aligned.

## Calibration of Transmitter

Required test equipment includes an milliammeter and *one* of the following:

- A Data Industrial Model 1200 Calibrator. The calibrator provides the means to key in the inside pipe diameter and displays the calibration flow rate in GPM. It is powered by two 9 VDC batteries for ease of transport and field use.
- Data Industrial Models 900T, 950T, or 1000 Flow Monitor can be used in place of the calibrator above.
- Frequency Counter.

The output of the Series 500 is a 4-20 mA signal providing a linear representation of flow rate. The user may select the best signal resolution for the flow range of the specific application by picking the most appropriate maximum and minimum outputs.

4 mA, the MINIMUM OUTPUT is normally set to represent a zero flow rate. However, it may be set to represent any flow rate up to 1/2 the maximum rate.

20 mA, the MAXIMUM OUTPUT represents the full scale of the device. Full scale flow rate should always be a number greater than the highest expected flow to protect against an over-range signal. The lowest full scale flow rate that may be set is a velocity of 5 feet/second.

By elevating the minimum flow, or reducing the maximum, the user may select the best resolution for the application.

For purposes of description, SPAN is defined as the difference between minimum and maximum. Since minimum is usually zero flow, span and maximum are typically the same value.

### **To calibrate**

1. Determine the desired values for minimum, maximum, and span. Minimum must be less than or equal to one half of span (typically zero flow).
2. With power off, Remove the sensor wires from 500 terminal strip. Replace with Model 1200 calibrator, Model 900T/950T, or frequency counter. (Consult Data Industrial flow sensor manual for calibration constants when using a frequency sourcing or readout device.). Refer to the appropriate owners manual of the device you are using.
3. Connect ammeter in series with the 4-20mA loop then power up loop.
4. Refer to Figure 3 on page 4 to locate calibration controls. Slide the RANGE switch to the "LOW" position.
5. Slide the CAL switch to "OFF" to get zero flow rate on calibrator or 0Hz on frequency counter.
6. Adjust the OFFSET POT to get a 4mA output on the ammeter.

7. Slide the CAL switch to "ON" and adjust the CAL POT to get a flow rate on the calibrator equal to the value of maximum. If you are using a frequency counter adjust CAL POT until full scale calculated frequency is achieved
8. Adjust the SPAN POT to get a 20mA output on the ammeter. **NOTE:** If this is not possible, then slide the range switch to "HIGH" and return to Step 4.

**If 4mA is to equal zero flow (Minimum = 0), skip to Step 11.**

9. Adjust the CAL POT to get a flow rate equal to the minimum flow rate.
10. Adjust the OFFSET POT to get an output of 4mA.
11. The calibration should now be complete. Verify settings by adjusting the CAL POT to get a flow rate equal to maximum and verify that the output is 20mA. If not, then fine adjust the SPAN POT to get 20mA and then recheck the minimum flow rate for 4mA output.
12. Slide the CAL switch to "OFF".

**If you are calibrating a Model 510-10 skip to "510-10 Display Calibration" located below**

12. Once output is satisfactory, turn off loop power and disconnect calibrator or frequency counter from sensor input terminals and remove ammeter from the 4-20mA loop. Reconnect the sensor according to electrical installation instructions.
13. Replace the cover. The unit is now ready for automatic operation.

## **510-10 Display Board Calibration**

The 510-10 display has four range selections (Jumper locations and ranges listed in figure 5). If the flow rate is greater than 1999 multipliers must be used. The display board calibration should be done **after** the 4-20mA span has been set on the analog board.

1. Remove power from loop then reference Figure 5 to select jumper location and multiplier for the desired span.
2. Apply power to loop and with the loop current at 4mA adjust display board offset pot until display reads 0. If minimum flow rate of analog transmitter higher than 0 then adjust display board offset pot until display reads desired flow rate.
3. Slide the transmitter board CAL switch to "ON".
4. With the loop current at 20mA adjust display board span pot to desired full scale flow.
5. Slide the transmitter board CAL switch to "OFF" and check offset display. Repeat steps 2-4 as necessary.
6. Attach Multiplier label to front cover of unit (If applicable).

**Data Industrial Series 500 Manual**

- Once output is satisfactory, turn off loop power and disconnect calibrator or frequency counter from sensor input terminals and remove ammeter from the 4-20mA loop. Reconnect the sensor according to electrical installation instructions.
- Replace the cover. The unit is now ready for automatic operation.

**Figure 5**

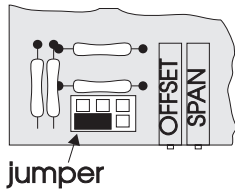

**Range 1000 - 1999**

**Example #1**  
If analog transmitter is calibrated for 0-1750 GPM the jumper would be moved to the 1000-1999 range and there would be no multiplier used.

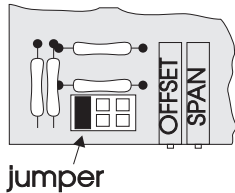

**Range 500 - 1000**

**Example #2**  
If analog transmitter is calibrated for 0-750 GPM the jumper would be moved to the 500-1000 range and there would be no multiplier used.

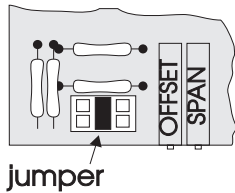

**Range 250 - 500**

**Example #3**  
If analog transmitter is calibrated for 0-2500 GPM the jumper would be moved to the 100-250 range or 250-500 range and there would be a X10 multiplier used.

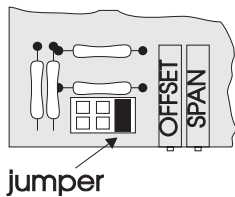

**Range 100 - 250**

**Example #4**  
If analog transmitter is calibrated for 0-22000 GPM the jumper would be moved to the 100-250 range and there would be a X100 multiplier used.

# Specifications

The Series 500/550 meets the requirements of ISA Type 2, Classes L, H and U. Non-isolated.

## **Maximum load resistance**

- 650 ohms at 23 V

## **Operating temperature range**

- 32 to 122°F (0 to 50°C) Model 510-10
- -20 to 150°F (-29 to 65°C) Model 500/550

## **Storage temperature range**

- 14 to 140°F (-10 to 60°C) Model 510-10
- -40 to 185°F (-40 to 85°C) Model 500/550

## **Power requirements**

- 4-20mA loop voltage
- 10 VDC minimum, 35 VDC maximum

## **Linearity**

- Better than 1%

## **Output response time**

- Six seconds (typical), 10 to 90% step response

## **Device output ripple**

- Less than 0.25% of full scale for a fully stable sensor input

## **Dimensions**

- 4.7" x 3.15" x 2.15"

## **Enclosure**

- Glass filled polyester. UL 94 VO (self extinguishing) burn rating. Watertight to NEMA 1, 2, 3, 3R, 4, 4X, 5, 12, and 13

## **Weight**

- .48 pounds

## Warranty

Data Industrial Corporation (“Seller”) of 11 Industrial Drive, Mattapoisett, Massachusetts 02739-0740, U.S.A., warrants to the original purchaser of its product that such product manufactured by Data Industrial Corporation shall be free from defects in materials or workmanship when installed, serviced and operated according to Data Industrial corporation instructions or in other such normal use. This warranty is effective for a period of 12 months from the date of installation by the Purchaser or 18 months from the date of shipment by the “Seller” whichever occurs or terminates first. This limited warranty does not cover damage or loss resulting from corrosion or erosion caused by acids or other chemicals or by severe environmental conditions or negligent or improper installation or improper operation, misuse, accident, unauthorized repair or substitution of components other than those provided by the “Seller”, and does not cover limited life components such as bearings, shafts, impellers where wear rate is a function of application and environment. Any component not manufactured by the “Seller” but included in its products shall not be covered by this warranty and is sold only under such warranty as the manufacturer may provide.

If Buyer or Purchaser wishes to make a claim hereunder, he shall send written notice of any defect within the warranty period, to “Seller” at the above address. “Seller” may at its sole option instruct Buyer to ship subject part, postage prepaid, to the “Seller” at above address or authorize a representative to inspect the part on site. “Seller” will at its sole option repair or replace any defective product covered by this warranty. If Buyer makes repairs or alterations to any product or part covered by this warranty without “Sellers” prior written approval, this warranty shall be null and void.

The foregoing shall constitute Buyers or Purchasers sole and exclusive remedy against “Seller”, and no other remedy, including but not limited to, incidental or consequential damages for personal injury, loss of fluids, gases or other substances or for loss of profits or injury to property or person shall be available to the Buyer or Purchaser. The warranty extended herein shall be in lieu of any other implied warranty of merchantability or fitness for a particular purpose, and seller shall bear no liability for representatives or retail sellers. In no event shall Data Industrial Corporation be liable for any contingent, incidental, or consequential damage or expenses due to partial or complete inoperability of its product.