

Badger® GALAXY® Remote

Remote Transmitter for RTR®, ADE® or Competitive Encoders for GALAXY Fixed Network

Installation Data

APPLICATION

The Badger Meter GALAXY® remote transmitter is available for all non-submersible settings in proximity to a Badger Meter water meter. The Recordall® Transmitter Register (RTR®) and Absolute Digital Encoder (ADE®) are permanently sealed to eliminate moisture, dirt, and other contaminants to insure reliable operation in outdoor nonsubmerged or indoor applications. The GALAXY transmitter is compatible with Badger Meter's Recordall® Disc, Turbo, and Compound Series, and Magnetoflow® Mag meter lines with the RTR, ADE, and the following competitive encoders: Sensus®, Neptune®, Hersey®, AMCO®, and Metron®.

IDENTIFICATION

Each GALAXY remote transmitter for the proper encoder is marked on the enclosure cover of the module with the name GALAXY, RTR, or ADE (used for competitive encoders) and a label on the outside of the module clearly identifies the serial number of the transmitter and the FCC assigned frequency for that specific utility (See Figure 1). Note that an FCC license is required for operation of the GALAXY system.



Figure 1. Identification – Galaxy Remote Transmitter

Each RTR or ADE is clearly identified on the face of the dial with an assembly number, unit of measure, and meter model (see Figure 2).

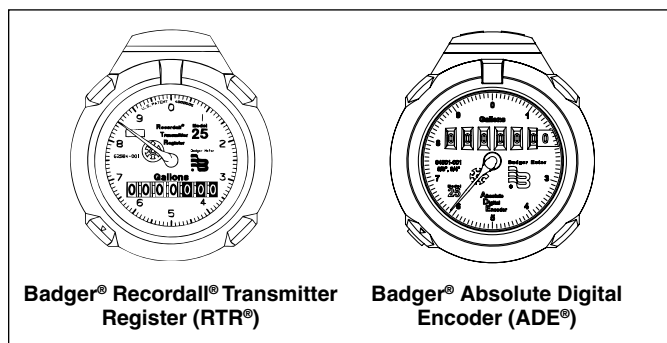

Figure 2. Identification

CAUTION

Changes and modifications to this product that are not expressly approved by Badger Meter, Inc. will void your authority to operate the equipment as originally approved by the Federal Communications Commission (FCC).

FACTORY SHIPMENTS

The Badger GALAXY remote transmitter and the encoder may be either factory wired together with a pre-defined length of lead wire, or the two units can be shipped as separate units and connected together in the field.

All transmitters are shipped factory programmed to the FCC assigned frequency. The transmitter is shipped in a dormant, non-transmitting condition and is activated at time of installation.

REQUIRED INSTALLATION TOOLS

- 64283-001 Programming Magnet
- 61658-003 TORX® #T-10 Driver

REQUIRED SPLICE TOOLS

- 59983-001 Gel Splice Crimping Tool
- 59989-001 Coax Wire Stripper
- 59991-001 Wire Cutting Pliers
- 59993-001 Wire Stripper

REQUIRED MATERIALS (User supplied)

Mounting hardware or fasteners to mount the remote transmitter to any vertical surface. Tools are dependent on type of mounting hardware used.

DETERMINE LOCATION FOR TRANSMITTER

The transmitter must be located in a suitable indoor or outdoor non-submersible environment. The best radio performance is achieved with the unit mounted outdoors, as high as possible, with a line-of-sight signal path to the receiving antenna (repeater or Gateway receiver). When located indoors the transmitter should be installed as high as possible and with minimal surrounding obstructions; for example, an ideal location would be in the floor joists along an outside basement wall. Keep the transmitter away from large metal objects such as water heaters and furnaces that may block the signal path.

INSTALLATION

Carefully remove the Badger GALAXY transmitter and the encoder register from the shipping carton and inspect the units for damage. Retain the contents of the installation kit for use in mounting and installing the transmitter in the field.

Before proceeding with the installation, be certain that the meter type and size correspond and that the proper encoder configuration has been supplied for the application.

CONNECTING THE ENCODER REGISTER

This step applies to encoder registers and GALAXY modules that are not factory wired. If the units have been factory wired, skip to Completing the Installation.

Cut off the gel splice connectors protecting the wires at the end of the encoder cable. Strip approximately 3/4" of outer insulation sheath from the encoder cable using the Coax Stripping Tool. Use caution in removing the outer sheath so that the inner signal wire insulation is not damaged.



Unwind the outer foil shield from the encoder cable and cut it off even with the outer sheath using the Wire Cutting Pliers.

Remove the Badger® GALAXY® cover using the TORX® driver. Locate the red, black and green wires at the bottom of the module. To connect the encoder register and the GALAXY, connect correct color wires of the two units together as follows:

	Badger	Sensus	Hersey	AMCO / ABB	Neptune
GALAXY Universal	RTR®, ADE®	ICE®, ECR®	Translator®	Scancoder®, InVISION®	ARB V®, ProRead®, Ecoder®
Red	R	R	R	G	B
Green	G	G	G	R	R
Black	B	B	B	B	G

Connect the encoder conductors to the GALAXY module conductors using the three gel connectors provided (p/n 59761-001). Fully insert the two paired wires into the two slots of one gel connector. DO NOT strip any insulation from the ends of the wires before inserting them into the connector. Before crimping, check to insure the wires are fully inserted to the end of the connector; failure to have the wires fully inserted may cause a faulty connection. Crimp the wires completely using the Gel Splice Crimping Tool or an equivalent parallel pliers; standard pliers will not provide the proper force to insure a reliable crimp. Connect each of the other two pairs of wires to the other two gel connectors in the same way.

Place the two plastic cable ties for strain relief on the encoder cable at the point where it will exit the transmitter module box. Tighten securely. Remove excess cable tie with wire cutting device.

Tuck the wire and connectors under the circuit board at the bottom of the transmitter module (See Figure 8). Be careful to insure the wire and connectors are not touching the circuit board itself; this could cause degradation of performance. Route the encoder cable out of the module through the access slot at the lower left corner of the box. Replace the cover and tighten the four TORX screws.

Refer to Figures 3 through 8 for illustrations of connecting the encoder to the GALAXY.

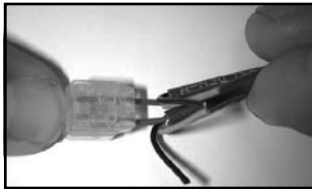

Figure 3. Push the wires that are to be connected together as far as possible into the connector.



Figure 4. Crimping Tool



Figure 5. Place the connector (with wires) into the jaws of the crimping tool.



Figure 6. Crimp the connector by squeezing the handles until the connector looks like this. Continue to apply pressure for three seconds.

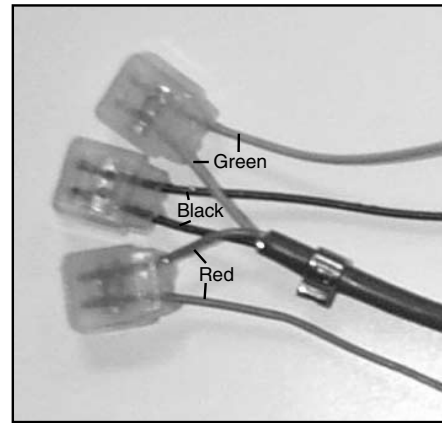

Figure 7. The encoder and GALAXY wires after crimping

COMPLETING THE INSTALLATION

If the GALAXY Remote transmitter is installed on an ADE or a competitive encoder the current meter reading will be read directly from the position of the odometer wheel stack of the encoder. No programming to the transmitter is needed.

If the GALAXY Remote transmitter is installed on an RTR register, please use your programming tool to program correct odometer wheel stack into transmitter.

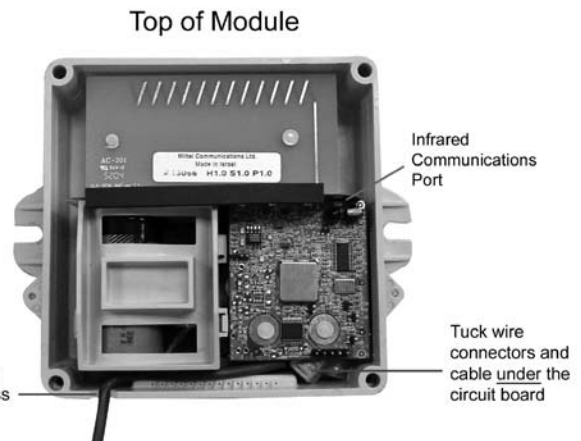

Figure 8. Tuck the wire and connectors under the circuit board at the bottom of the transmitter module. Be careful to preclude the wire and connectors from touching the circuit board itself. Route the cable out of the module.

Mount the transmitter using appropriate mounting hardware. Note that the mounting bracket can be rotated 90 degrees for additional flexibility in mounting (See Figure 9). Make sure the transmitter module is mounted so that the encoder cable exits the module at the bottom left; this insures the antenna will be at the top of the module.

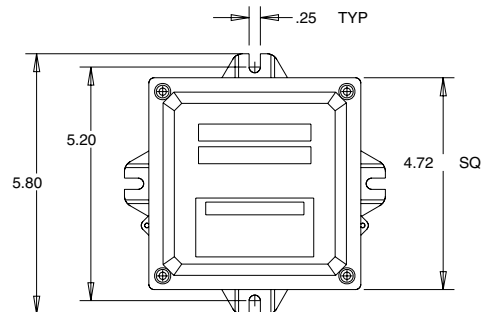

Figure 9. GALAXY® Remote Transmitter dimensions

Install the encoder on the water meter and secure it using the TORX® screw provided.

ACTIVATION

The Badger® GALAXY® remote transmitter is shipped in a dormant, non-transmitting condition. It is activated by holding a magnet to the lower right corner of the housing (Figure 10) for three seconds.



Figure 10. Activating or forcing a transmission using a magnet

FORCING A TRANSMISSION

After activation, a transmitter can be forced to send a reading. To do so, hold a magnet to the lower right corner of the housing (Figure 10) for three seconds. To attempt a retry, a 30-second period needs to elapse.

DISABLING

A properly operating transmitter should not be turned off once it is activated. A transmitter can be disabled for special circumstances, such as return shipment of a defective unit for warranty purposes. To disable a transmitter, use the Badger Handheld tool in conjunction with the infrared port in the transmitter module.

CUT CABLE

If the wire is cut or broken and requires a field splice after initial installation, connect correct color wires (see wiring chart) to maintain proper installation.

TRANSPORTATION

The Federal Aviation Administration prohibits operating transmitters and receivers on all commercial aircraft. When powered, the GALAXY transmitter is considered an operating transmitter and cannot be shipped by air.

FCC COMPLIANCE

This product complies with Part 90 of the Federal Communications Commission Rules. An FCC license is required for operation of the GALAXY system.

Badger®, Recordall®, Magnetoflow®, GALAXY®, RTR®, and ADE® are registered trademarks of Badger Meter, Inc.
Torx® is a registered trademark of Camcar, Division of Textron, Inc.
Sensus®, ICE®, and ECR® are registered trademarks of Sensus Metering Systems-North America Inc. and its subsidiaries and affiliates.
Neptune®, ARB V®, ProRead®, and Ecoder® are registered trademarks of Neptune Technology Group.
Hersey® and Translator® are registered trademarks Hersey Products Inc.
AMCO®, Scancoder®, and InVISION® are registered trademarks of Elster AMCO Water, Inc.
Metron® is a registered trademark of Metron-Farnier, LLC.

Due to continuous research, product improvements and enhancements, Badger Meter reserves the right to change product or system specifications without notice, except to the extent an outstanding contractual obligation exists.



Please see our website at
www.badgermeter.com
for specific contacts.



BadgerMeter, Inc.

P.O. Box 245036, Milwaukee, WI 53224-9536
(800) 876-3837 / Fax: (888) 371-5982
www.badgermeter.com