

STANDARD TOP GUIDED TRIM

This style trim guiding is the standard for most 1/4" and 1/2" Research Control Valves. The stem diameter for 1/4" valves with this trim style is 1/8".

Trim sizes "F" through "J" have two piece plug/stem assemblies. Trim sizes "K" through "P-18" are machined integrally onto the stem. "A" through "E" have two piece plug/stem assemblies. Trim sizes "F" through "O" are normally machined integrally onto the stem. The only exception is for a stellite plug. In that case the stem may be either machined integrally or screwed to the stem.

For maximum allowable pressure drops, refer to Document No. 941137 "Selection Guide for Standard Applications" or consult the factory.

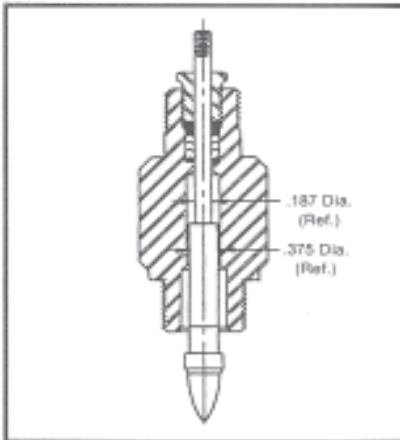

MEDIUM GUIDED TRIM

This style trim is the standard for most 3/4" and 1" Research Control Valves and optional on some 1/4" and 1/2" models. The stem diameter through the packing is the same as the top guided 1/4" and 1/2" trims. The stem diameter on 3/4" and 1" valves is the same as in the 1/2" valve: 3/16".

As mentioned in "Selection Guide for Standard Applications" No. 941137, this trim should be used when the pressure drop exceeds the limit of the top guided trim, especially 1/2" trims "A" through "E."

In the 1/2" valve, this trim is interchangeable with the standard top guided trim.

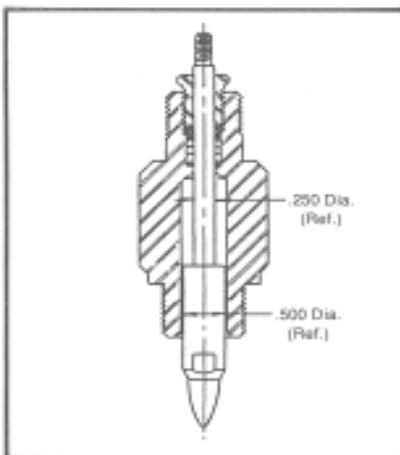

HEAVY DUTY GUIDED TRIM

This style trim guiding is optional in the 1/2" Research Control Valve. The stem diameter on trims of this type is 1/4". Selection Guide for Standard Applications" indicates when this type trim guide should be used, such as for high pressure drops, especially trims "A" through "E."

Note: This trim style is NOT interchangeable with either the top or medium guided trim. Retrofittings of this style trim require the changing of the bonnet assembly, due to the stem diameter difference.

Please see our website at
www.badgermeter.com
 for specific contacts.

Due to continuous research, product improvements and enhancements, Badger Meter reserves the right to change product or system specifications without notice, except to the extent an outstanding bid obligation exists.



BadgerMeter, Inc.

P.O. Box 581390, Tulsa, Oklahoma 74158
 (918) 836-8411 / Fax: (918) 832-9962

www.badgermeter.com