

<p>Model AR/e – AR/t & RTR</p>	<p>Water Treatment Control System</p>	<p>Installation & Operation Manual</p>
---	--	---



IMPORTANT !!!! Read this manual before attempting any installation, wiring or operation.

Service Information (File manual for future reference and service.)	
Serial Number _____	Date Installed ____/____/____
Service Line _____	Operator _____



▪ **SCOPE OF THE MANUAL**

This manual contains information concerning the installation, operation and maintenance of the AR/e with AR/t or RTR Water Conditioning Control System. To ensure proper performance of the system, the instructions given in this manual should be thoroughly understood and followed.

Keep the manual in a readily, accessible location for future reference.

Changes and additions to the original edition of this manual will be covered by a "Change Notice" supplied with the manual. The change notice will explain any differences between the product received and the product described in this manual.

▪ **TABLE OF CONTENTS**

	Page
Unpacking and Inspection	2
INSTALLATION	
Surface Mounting or Pipe Mounting	3
Panel Mount	3
Wiring Precautions & Procedures	3
Battery Installation	3
AC Power Connections	3
Transmitter Connections (AR/t & RTR).....	4
Lockout Signal Connections	4
Remote Start & Stop Connections	4
Connecting to Other Equipment	5
OPERATION	
Forced Regeneration	6
Aborting Regeneration cycle	6
Overriding Preset Batch Value	6
PROGRAMMING	
General Programming Procedures	5
Setting For Manual/Auto Operation	5
Setting AR/e to Type & Size of Meter	5
Batch Size	6
Output Signal Duration	6
Start-up Check List	6
TROUBLESHOOTING	
Self-test Procedure	6
Replacement Parts	6
Troubleshooting Chart	7

▪ **UNPACKING & INSPECTION**

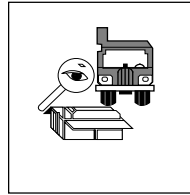

To avoid damage in transit, Badger products are shipped to the customer in special shipping containers. Upon receipt of the product, perform the following unpacking and inspection procedures.

Note: If damage to the shipping container is evident upon receipt, request the carrier to be present when the product is unpacked.

a. Carefully open the shipping container following any instructions that may be marked on the box. Remove all cushioning material surrounding the product and carefully lift the product from the container.

Retain carton and packing material for use in re-shipment or storage of unit.

b. Visually inspect the product and applicable accessories for any physical damage such as scratches, loose or broken parts or any other sign of damage that may have occurred during shipment.

Note: If damage is found, request an inspection by the carrier's agent within 48 hours of delivery and file a claim with the carrier. A claim for equipment damaged in transit is the sole responsibility of the customer.

▪ **INSTALLATION**

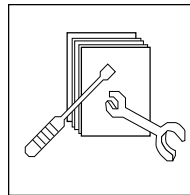

The AR System consists of a Badger Disc or Turbo meter with the AR/t or RTR pulse transmitter and the AR/e Conditioning Controller. Normally, the transmitter will be mounted on the meter. It does not require any additional mounting procedure. All transmitters use a simple bayonet mount and a seal screw to attach to the meter.

Note: Always be sure to match the transmitter to the proper meter. A red dot on the AR/t transmitter dial indicates the meter model and size for which the transmitter is intended. The RTR dial face has the model designation of the appropriate meter.

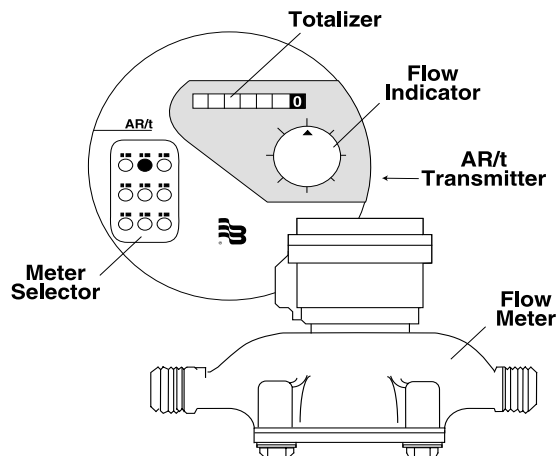

MOUNTING

The AR/e controller comes in a rugged, watertight polycarbonate enclosure intended for wall, pipe or panel mounting. The package contains two sets of mounting screws and "O" rings which must be used to maintain the NEMA 4X rating of the enclosure.

When mounting the unit select a location which has adequate ventilation, protection against mechanical shock and accessibility for operation and service.

Operating Temperature: 32° to 130° F (0° to 55° C)
Operating Humidity: Up to 85% non-condensing

Using a 5/32" Allen wrench, remove the four corner screws in the housing.

Separate the front and rear halves of the housing. Keep the screws and housing gasket in an accessible location.

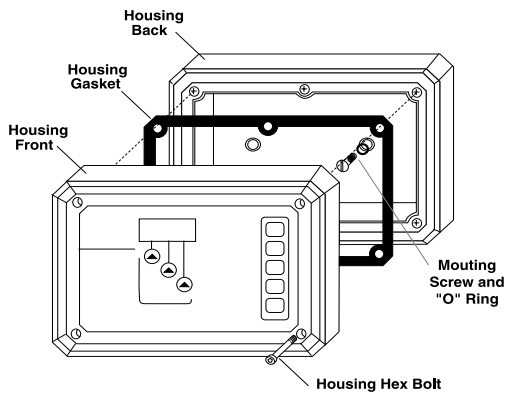

Wall or Pipe Mount

1. Using the appropriate mounting hardware attach the back part of the housing to the mounting surface.
2. Wire the unit (see wiring procedures on this page).
3. Carefully place the housing gasket in place and bolt the front part of the housing to the back part.

Panel Mount

1. Use the housing gasket to mark and drill the panel.
2. Drill a 3/4" hole in the panel for the fuse holder.
3. Wire the unit (see wiring procedures on this page).
4. With the housing gasket properly placed on the front housing, mount the unit to the panel.

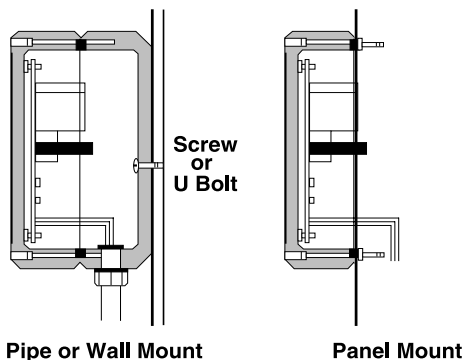

WIRING PROCEDURE

Three plug-in terminal block assemblies are provided for connecting 28 to 14 gauge insulated wire. Solid or stranded wire can be used.

It is recommended that wiring be carefully planned and laid out before installation. This will help determine the amount of space needed for wiring as well as the final location of the unit.

Detail diagrams in this section illustrate proper wiring procedures for all standard and optional functions.

Be sure to comply with the wiring requirements and all applicable electrical codes.

Note: Terminal block assembly unplugs from printed circuit board for ease in connecting field wiring.

Disconnect all power to the unit before connecting wires to any of the terminals. Do not use machine power service. A dedicated or lightning circuit is recommended.

INSTALL BATTERY ON CIRCUIT BOARD ONLY AFTER WIRING IS COMPLETED.

POWER INPUT

The AR/e is designed to work with a 110 VAC power supply. In case of power failure, the unit will retain all programmed values and continue to count down (without display or output) for several hours. When power is restored, the unit will send an output signal if enough pulses have accumulated during power outage. If the power down period exceeds the battery capacity, the last known batch count and other programmed values will be stored until the power comes back on. (Battery requires a minimum of 24 hours to recharge from a fully discharged condition.)

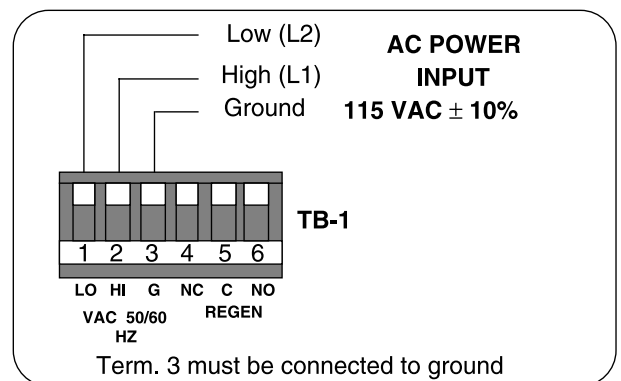

PULSE INPUT (AR/t)

The AR/t transmitter sends pulse signals to the AR/e controller. Each pulse represents a specific quantity of water for a particular meter size.

Meter	Pulse Rate
RCDL Models 25, 35 and 40	1 pulse = 1 Gallon
RCDL Models 70, 120, 170 and Industrial Turbo 2", 3" and 4"	1 pulse = 10 Gallons
Industrial Turbo 6"	1 pulse = 100 Gallons

Reed switch transmitters have two black leads. Connect these leads to terminals 1 & 2 in any order.

Electronic transmitters have one black lead and one white lead. Connect these leads as per the diagram at right.

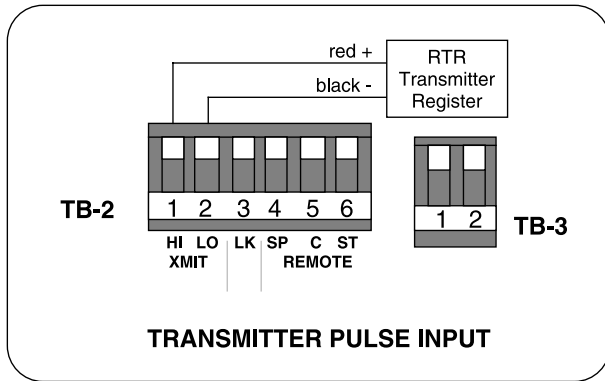

PULSE INPUT (RTR)

The RTR transmitter/register sends pulse signals to the AR/e controller. Each pulse represents a specific quantity of water for a particular meter size.

Meter	Pulse Rate
RCDL Models 25, 35, 40, & 70	1 pulse = 1 Gallon
RCDL Models 120 and 170	1 pulse = 10 Gallons
RCDL Turbo Series 1 1/2" - 6"	1 pulse = 100 Gallons

These transmitters have one black lead and one red lead. Connect these leads as per the diagram.

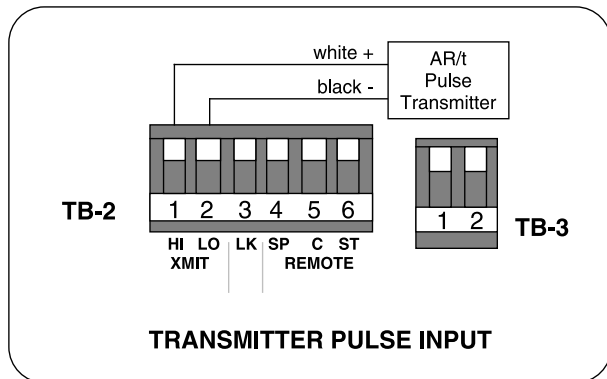

RELAY OUTPUT

The regeneration signal relay is energized at the end of the batch or when a START command is initiated.

In the Manual mode, the relay will remain energized until the SIGNAL STOP is initiated. The relay contacts can be used to activate a warning device to indicate that manual regeneration of the system is necessary.

In the Automatic mode, the relay will be energized at the end of the batch for the amount of seconds programmed via the SIGNAL DURATION procedure (see page 6). The relay contacts can be wired to a timer or regeneration cycle controller.

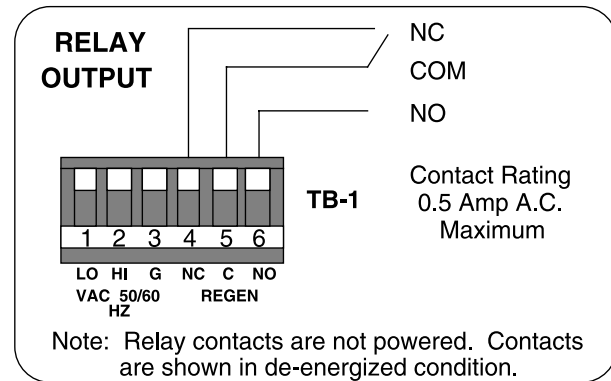

REMOTE START & STOP (OPTIONAL)

Remote Start Input

When activated, it will abort a batch before its completion, initiating tank regeneration at the same time.

In the **Manual** mode, the output relay will be energized indefinitely and the display will be reset to zero until the STOP command is received.

In the **Automatic** mode, the output relay will be energized for the programmed duration (see operation section page 6) and the display will be reset to the batch preset value and continue to count down when pulses are received.

If a **START** command is received while the LOCKOUT is active, the command will be stored in memory and acted upon as soon as the LOCKOUT signal is terminated.

Remote Stop Input

Is used to terminate the output signal. This function is enabled after a START command is received or after the output relay is energized at the end of the batch.

In the **Manual** mode, it will terminate the output signal, reset the counter to the batch preset value and enable the transmitter pulse input.

In the **Automatic** mode, it will only terminate the output signal.

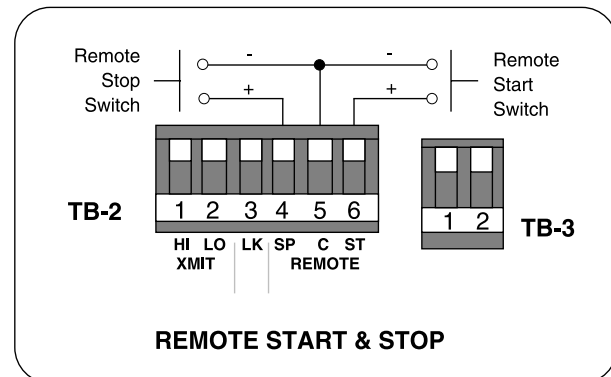

LOCKOUT INPUT (OPTIONAL)

To avoid simultaneous regeneration of multiple tanks, a lockout signal can prevent a controller from sending a regeneration signal at the end of the batch.

The regeneration signal will be sent as soon as the lockout signal is terminated. A lighted decimal point at the lower right corner of the display will indicate the presence of a lockout signal. (An open collector/switch contact or a 115 VAC signal can be used as the lockout signal.) When using a 115VAC lockout signal, the lockout logic can be reversed. (See settings for Switch 2 in section below.) If the 115VAC lockout signal is not used, Switch 2 must be in the off position. The lockout signal will be ignored if the output is energized.

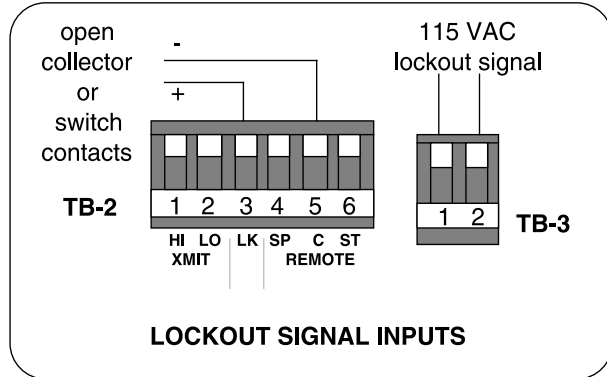

SELECTING THE MODE OF OPERATION

Select the mode of operation and maximum batch size required for your particular system. (For location of switches, see page 7.)

Switch 1: ON (**Manual** operation)
OFF (**Automatic** operation)

Switch 2: ON (**Lockout** when 115VAC is **not** applied to TB-3)
OFF (**Lockout** when 115VAC is applied to TB-3)

Note: Switch 2 must be in the off position when not using 115 VAC lockout function.

Switches 3 & 4: (See chart) Set switches for the maximum batch size for your particular size of meter.

Example: You have a 2" Industrial Turbo meter and your batch size is 500000 gallons, set switch 3 to the off position, and set switch 4 to the off position. (This will allow you to set a maximum batch size of 999000 gallons.) Attach the X1000 sticker to the front panel.

Batch Capacity Selection Table			
Zeros are not displayed.			
Attach appropriate multiplier label to front panel.			
Switch Position	on <input type="checkbox"/>	Max. Preset Value in US Gal. for Meter Size (inches)	
1 2 3 4 <input type="checkbox"/> <input type="checkbox"/> <input checked="" type="checkbox"/> <input checked="" type="checkbox"/> X1		RCDL 25, 35, 40 & 70 (RTR)	RCDL 70 (AR/I), 120 & 170 and Ind. Turbo 2", 3" & 4"
		999 blank	9990 X10
1 2 3 4 <input type="checkbox"/> <input type="checkbox"/> <input checked="" type="checkbox"/> <input checked="" type="checkbox"/> X10		9990	99900
		X10	(no label)
1 2 3 4 <input type="checkbox"/> <input type="checkbox"/> <input checked="" type="checkbox"/> <input checked="" type="checkbox"/> X100		99900	999000
		(no label)	X1000
1 2 3 4 <input type="checkbox"/> <input type="checkbox"/> <input checked="" type="checkbox"/> <input checked="" type="checkbox"/> X1000		999000	9990000
		X1000	X10000

OPERATION

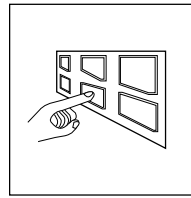

The basic function of the AR/e controller is to provide a signal to external equipment once a predetermined amount of water has been measured by the water meter. The batch is preset and the display counts down to zero. At this point the output relay is energized for a programmed period of time providing the necessary signal for manual or automatic regeneration.

The controller is designed to function with a minimum of operator control after the initial setup procedures. All displays and controls are located on the front panel for fast, accurate and convenient operation.

GENERAL PROGRAMMING PROCEDURE

In addition to the LED display and the digit keys, the front panel of the AR/e controller has two command keys (START and STOP) and three program keys (PRESET, SIGNAL DURATION and UP-DOWN COUNT).

To prevent tampering or accidental mistakes, the keys must be depressed twice in succession for the command to be recognized and acted upon. **If the second command is not received within ten seconds of the first, the unit will revert back to its previous operation.**

PROGRAMMING SEQUENCE

To interrogate the present value of a programmable function, depress the appropriate function key. The display will show the function symbol and the present value of the function alternately for ten seconds and then revert back to normal operation.

To preset a new value, press the appropriate key and change the value by using the "digits" keys. Pressing a digit key continuously will cause the number to scroll. When the desired number is reached, remove your finger from the digit key. Change one digit at a time, within ten seconds of each other. After the new value is displayed, press the key again, to store it in memory.

The unit will not react to any new values until it counts down to zero. To accept the new values immediately, "zero" the unit using the UP/DOWN key.

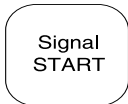
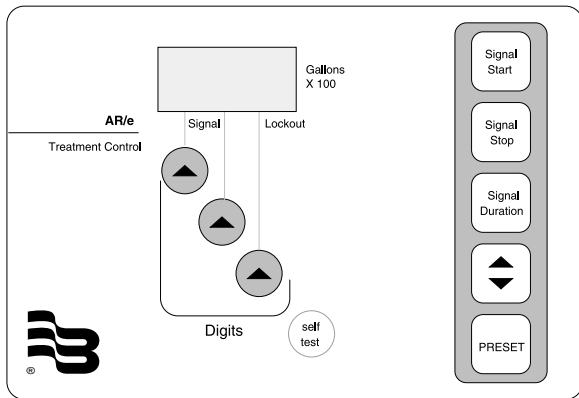

The **START** and **STOP** command keys have the same effect as the equivalent remote functions (see wiring section on page 4). The key must be depressed twice in succession for the command to be recognized and acted upon.

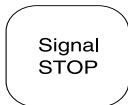

The **PRESET** key is used to set the amount of water to be measured before tank regeneration is required. The preset value is a three digit variable number times a multiplier. Depress the key and the display will show the present preset batch value and the preset symbol. Use the digit keys to set the new value. Depress the **PRESET** key again to enter the new value in memory.



The **UP/DOWN** key is used to "zero" the unit or change the present count to a larger or smaller number in order to avoid simultaneous regeneration in multi-tank systems. The new number **will** affect the batch in progress.

- Depress the key and the display will show the present batch count and the UP/DOWN symbol.
- Use the digit keys to change the count value.
- Depress the UP/DOWN key again to enter the new count value in memory.



The **SIGNAL DURATION** key is used to preset the time period for which the output relay will remain energized at the end of a batch, or when a START command is received. The default value for signal duration is 5 seconds. This function is valid only if the control is set to operate in the automatic mode. The duration can be programmed from 1 to 999 seconds.

- Depress the key and the display will show the present signal duration period and the function's symbol.
- Use the digit keys to change the period.
- Depress the **SIGNAL DURATION** key again to enter the new value in memory.



The **SELF TEST** key is used to run a self test procedure in case of malfunction. The procedure itself and the diagnostic is explained in the Troubleshooting section on this page.

▪ TROUBLESHOOTING

Most problems encountered when applying the AR/e control are due to wiring errors, improperly set functions or faulty transmitter connections. This section provides guidelines for the detection and correction of these and other problems. However, should the problem persist, contact our nearest representative or the factory for further assistance.

SELF TEST PROCEDURE

1. Switch power off and on again. If the displays shows anything but three eights, an error exists in the processor and the unit has to be replaced.
2. If self test is satisfactory proceed to test the input switches as follows:
 - a. Press the **hidden test switch** twice. At first the display will show three fives then one eight.
 - b. Press all keys once in the following sequence: Signal START (7), Signal STOP (6), Signal Duration (5), UP/DOWN (4), PRESET (3), Hidden Test Switch (2), least significant digit (1), center digit (0), and most significant digit (Batch Count). Each time a key is depressed the appropriate number will be displayed. If one of the numbers remain in display after the next key is depressed, that particular input is defective.

▪ START-UP CHECKLIST

1. Set DIP switch 1 for manual or automatic operation.
2. Set DIP switch 2 for proper lockout operation. (Set to "off" position if not used.)
3. Set internal DIP switches (3 & 4) for meter size and maximum batch size.
4. Install NiCad battery.
5. Program unit for batch size wanted.
6. Program unit for output signal duration wanted.
7. "Zero" the unit using UP/DOWN key.

▪ FIELD REPLACEABLE PARTS

The following parts can be obtained locally. Brand names and model numbers are for reference only.

Relay: Potter & Brumfield® T81H5D212-05 (or equal)

Fuse: Fusetron® slow blowing 1/10 amp MDL series (or equal)

Battery: Eveready® CH22 7.2 volt NiCad rechargeable battery
(Do not use non-rechargeable battery.)

If you find it necessary to send unit to factory, contact your Badger representative or dealer for material return authorization. Package the unit properly, and include a brief description of the problem.

PROBLEM	POSSIBLE CAUSES	REMEDIES
Display does not light when AC power is turned on.	<ol style="list-style-type: none"> 1. No power on terminals 1 and 2. 2. Blown fuse. 3. Shorted power wiring. 	<ol style="list-style-type: none"> 1. Connect terminals 1 and 2 to power source. 2. Replace fuse. 3. Remove short circuit.
Counter does not decrement when transmitter is activated.	<ol style="list-style-type: none"> 1. No flow through meter. 2. Defective transmitter. 3. Transmitter improperly connected. 4. Dip switches improperly set. 	<ol style="list-style-type: none"> 1. Establish flow through meter. 2. Replace transmitter 3. Correct wiring error. 4. Verify switch settings for your meter size.
Regeneration output is not energized at end of batch or when a START command is received. (Signal indicator is lit.)	<ol style="list-style-type: none"> 1. Defective relay. 2. Lockout is active. 	<ol style="list-style-type: none"> 1. Replace relay. (See page 7.) 2. Check switch 2 position and wiring to lockout terminals.
Cannot change programmed values.	<ol style="list-style-type: none"> 1. Function key is not being pressed twice. 2. Unit not "zeroed" with UP/DOWN key. 	<ol style="list-style-type: none"> 1. Refer to page 6 for proper programming sequence. 2. Use UP/DOWN key to "zero" unit, which will force acceptance of new values.
Regeneration signal is active when signal light is off.	<ol style="list-style-type: none"> 1. Output is improperly wired. 2. Unit is defective. 	<ol style="list-style-type: none"> 1. Correct wiring errors. 2. Replace unit.
Test procedure does not work.	<ol style="list-style-type: none"> 1. Unit is defective. 	<ol style="list-style-type: none"> 1. Replace unit.
Memory does not function during power outage.	<ol style="list-style-type: none"> 1. Battery is defective. 	<ol style="list-style-type: none"> 1. Replace battery.

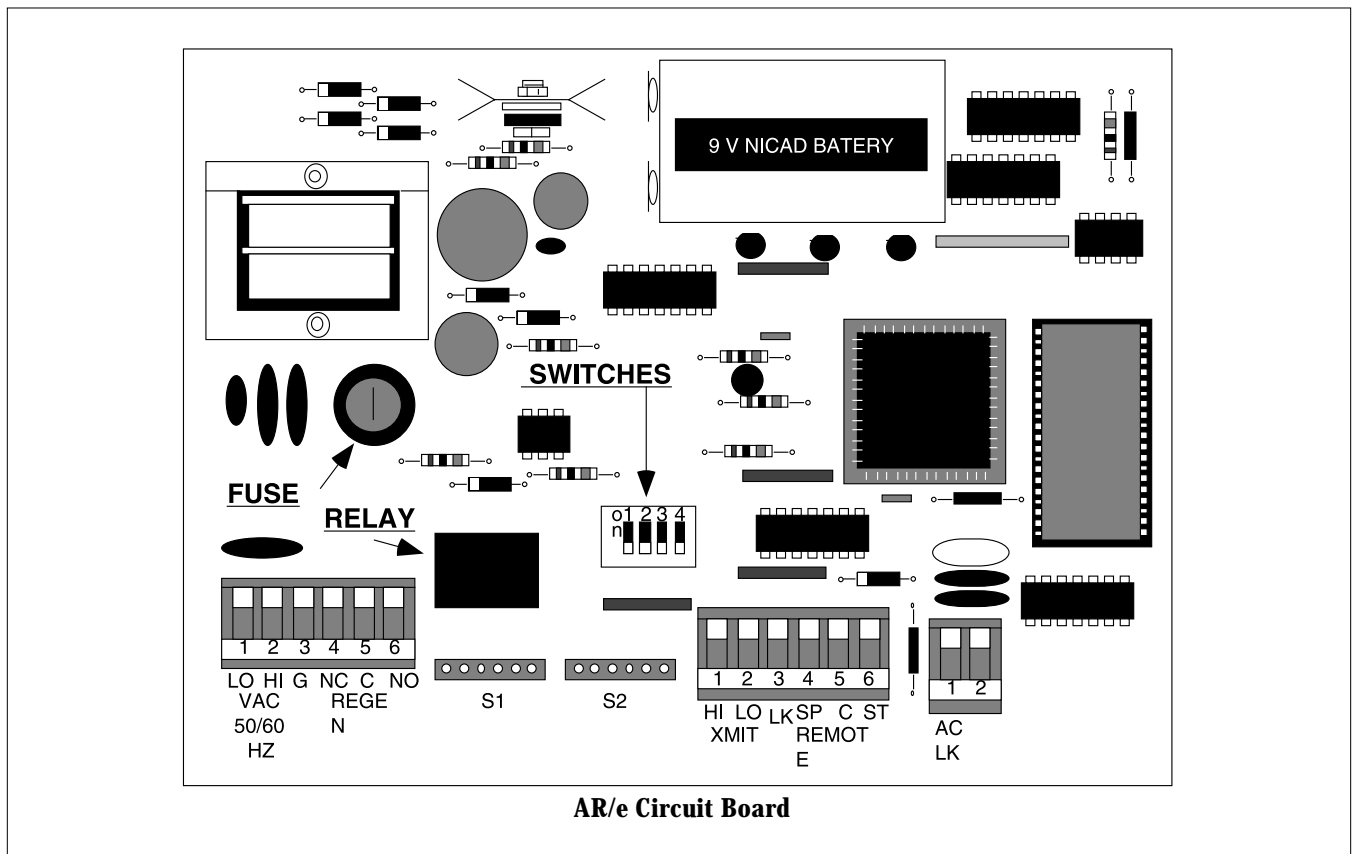



Please see our website at
www.badgermeter.com
for specific regions and contacts.

Due to continuous research, product improvements and enhancements, Badger Meter reserves the right to change product or system specifications without notice, except to the extent an outstanding bid obligation exists.



BadgerMeter, Inc.

P.O. Box 245036, Milwaukee, WI 53224-9536

Telephone: (414) 355-0400 / (877) 243-1010

Fax: (414) 355-7499 / (866) 613-9305

www.badgermeter.com