

OVERVIEW

The innovative design of Badger's M-Series® Mag Meter Model M-3000 amplifier represents the next generation of electromagnetic (mag) flow meter signal processing. Incorporating the latest developments in microprocessor signal conditioning, the advanced design of the M-3000 allows an accuracy of better than $\pm 0.25\%$ with a flow range of 300:1. The M-3000 amplifier can be integrally mounted to the detector or can be mounted remotely if necessary. Housed in a FM approved Class I, Div 2, NEMA 4X/6P (IP66/IP67) enclosure, the amplifier is targeted to a variety of applications and is well suited for the diverse water and wastewater treatment industry.

OPERATION

As the analog signal is received from the detector, the amplifier increases the signal amplitude and converts it into digital information. The internal microprocessor analyzes the signal and separates the electrical noise from the actual signal utilizing a series of sophisticated mathematical algorithms. Additionally, the microprocessor controls the zero flow stability, excitation frequency analog and pulse outputs, user display interface and a variety of other parameters and settings. The 4 line by 16 character, LCD simultaneously indicates flow rate, forward and reverse totalization, and error and diagnostic messages. The LCD also prompts the user through an easy to use programming sequence that allows user-friendly and quick field set up.

Programmable parameters of the amplifier include: calibration factors, totalizer resets, unit of measure, analog and pulse output scaling, flow alarm functions, language selection, low-flow cutoff, noise dampening factor, and excitation frequency selection.

APPLICATION

The M-3000 amplifier's primary function is to condition the electrical signal received from the detector. The unit is ideally suited for use in applications where the indication of rate and totalization is required. The ability to display flow parameters locally at the flow meter, or remotely, by mounting the amplifier up to 100 ft. (30M) away from the detector, provides a versatile solution for a variety of pit and meter vault applications. For applications where dedicated batch controllers, PLC's or computer control systems are in use, the M-3000 amplifier provides pulse and analog output signals that are compatible with most of these devices. The flow meter is powered from standard AC line voltages or optionally utilizing a 24VDC power input. The design has been tested and approved by Factory Mutual (FM) in the United States and the Canadian Standards Association (CSA International) in Canada.

**M-3000 Amplifier****FEATURES**

- FM approved for Class I, Div 2 hazardous locations
- CSA Certified
- Digital Signal Processor (DSP) based
- CE and FCC compliant
- Large 4 line by 16 character, back-lit, LCD display
- User friendly programming and set-up
- Digital and analog outputs
- Optional 24VDC power input
- NEMA 4X/6P (IP66/IP67) enclosure
- Detector or remote wall mount
- Bi-directional flow sensing/totalization
- Automatic zero point stability
- Better than 0.1% repeatability
- Measures fluids with as low as 5.0 micromhos/cm conductivity
- Empty pipe detection
- Language available in English, Spanish, French, or German
- Self diagnostics



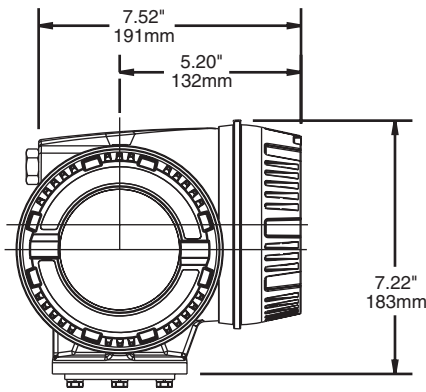

M-3000 Meter Mount Amplifier

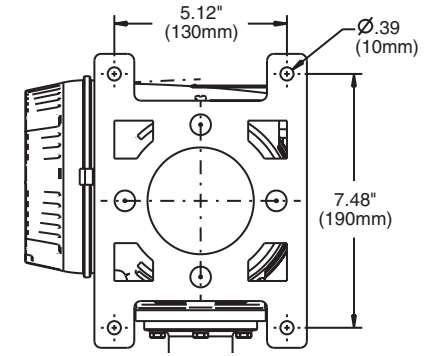
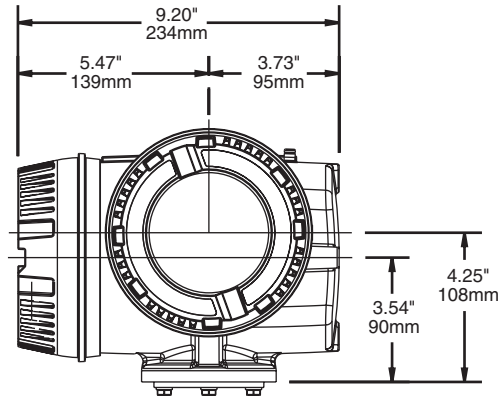

**M-3000 Remote Mount Amplifier
(shown with bracket)**

SPECIFICATIONS

Power Supply: AC or optional 24VDC
AC Power Supply - 85-265VAC 45-65Hz
 Voltage Fluctuation = $\pm 10\%$ of nominal
 Over Voltage = Catagory II
 Power Consumption = 20W
DC Power Supply - (optional) 24VDC $\pm 10\%$ 8W

Accuracy: $\pm 0.25\%$ of rate for velocities greater than 1.64 ft/s (0.50 m/s)
 ± 0.004 ft/s (± 0.001 m/s) for velocities less than 1.64 ft/s (0.50 m/s)

Repeatability: 0.1% of rate

Flow Range: 0.10 to 39.4 ft/s (0.03 to 12 m/s)

Fluid Conductivity: Min. 5.0 micromhos/cm

Flow Direction: Uni-directional or bi-directional (programmable)

Totalization: 3 separate displayable totalizers – 10 digits (programmable - forward, reverse and net)

Analog Outputs: 0-10mA, 0-20mA, 4-20mA (programmable and scalable)
 Voltage sourced (18VDC) – isolated
 Max. loop resistance = 750 Ω

Frequency Output: Open Collector – Max. full scale flow = 10Khz

Digital Outputs:
 (2) Open Collector, (programmable – scaled pulse, flow alarm, status, or frequency output) Max. 24VDC, 0.5W
 (2) AC solid state relay (programmable – flow alarm or status) Max. 24VDC @ 0.5A

Communication: RS232C serial, standard ANSI terminal compatible data stream

Pulse Width: Open Collector, 5ms to 1 second (programmable) or automatic 50% duty cycle

Min-Max Flow Alarm: Open collector or solid state relay (programmable – 0 to 100% of flow)

Empty Pipe Detection: Field tunable for optimum performance based on specific application

Excitation Frequency: Programmable - 3.75Hz, 7.5Hz or 15Hz

Auxiliary Input: Max. 24VDC (programmable – positive zero return, external totalizer reset or preset batch start)

Noise Dampening: 1 to 30 seconds (programmable)

Units of Measure: U.S. gallons, imperial gallons, million gallons per day, cubic feet, cubic meters, liters, oil barrels, pounds, ounces, acre feet (programmable).

Low Flow Cut-Off: 0 to 100% of full scale (programmable)

Zero-Point Stability: Automatic correction

LC Display: 4 line by 16 character, alphanumeric – back light
 Displays: 3 totalizer values, flow rate, alarm status, output status, error/diagnostic messages

Programming: Internal 3 button or external magnetic wand

Galvanic Separation: 500 volts

Electrical Classification: FM approved for Class I, Div 2, Groups A-D
 Class II, Div 2, Groups F and G, – CSA Certified

Housing: Amplifier enclosure and remote junction enclosure: cast aluminum (powder coated paint)

Housing Rating: Amplifier enclosure and remote junction enclosure – NEMA 4X/6P (IP66/IP67)

Mounting: Direct detector mount or remote wall mount – bracket included. (for remote mount, max. cable distance = 100 ft (30M))

Field Wiring Entry Ports: (3) $\frac{1}{2}$ " NPT, internal thread

Ambient Temperature: -4 to 122°F (-20 to 50°C)

Relative Humidity: Up to 90% non-condensing

Locations: Indoor and outdoor

Altitude: Maximum 6500 feet (2000m)

M-Series® is a registered trademark of Badger Meter, Inc.

Please see our website at
www.badgermeter.com
 for specific contacts.



BadgerMeter, Inc.

P.O. Box 245036, Milwaukee, WI 53224-9536
 Telephone: (414) 355-0400 / (877) 243-1010
 Fax: (414) 355-7499 / (866) 613-9305
 www.badgermeter.com

Due to continuous research, product improvements and enhancements, Badger Meter reserves the right to change product or system specifications without notice, except to the extent an outstanding contractual obligation exists.