

Model TR

Industrial Totalizing/Reset Register

Repair Parts

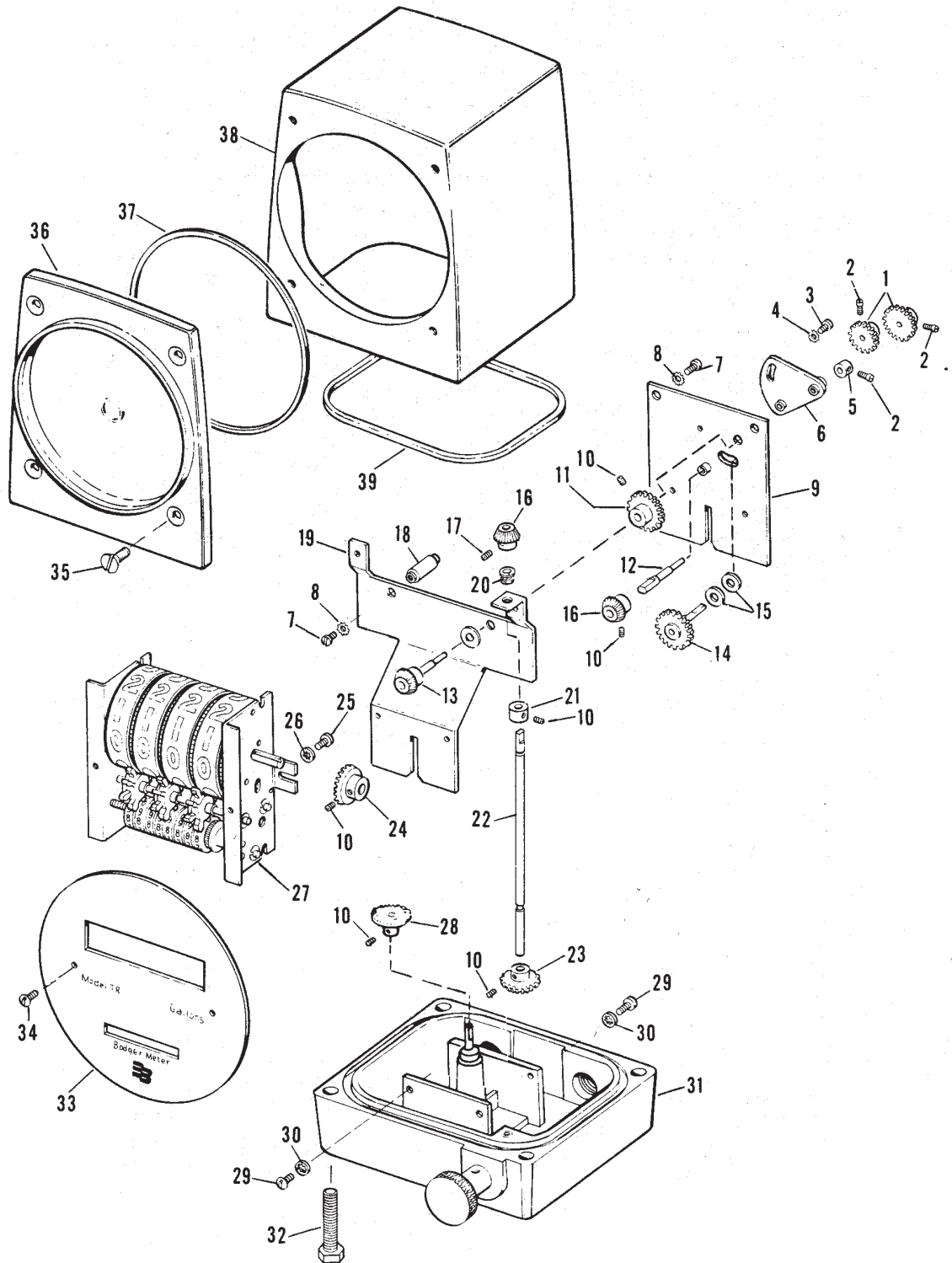

BadgerMeter, Inc.

IRP-022-06
Part No. 53401-022

ORDER INFORMATION: This repair parts bulletin shows an exploded view of the product with specific reference to those items available for replacement. The item number and part number may change at any time; therefore it is important when placing an order that a complete description of the part, meter size, model and serial number be provided.

ITEM	PART DESCRIPTION	PART NUMBER
1	Change Gears (Spec. No. Teeth	32652-00000
2	Setscrew, 4-48 x 1/8	1065-00000
3	Round Head Screw, 4-40 x 3/16	55109-11300
4	Lockwasher No. 4	55281-00500
5	Collar	58023-00100
6	Adjusting Plate Assembly	56867-00200
7	Pan Head Screw, 6-32 x 5/16	55089-16900
8	Lockwasher, No. 6	55281-00700
9	Rear Mounting Plate Assembly	58096-00100
10	Setscrew, 6-32 x 1/8	55230-16500
11	Change Gear Assembly	26459-03000
12	First Spindle	57995-00100
13	Third Spindle Assembly	58095-00100
14	Change Gear Spindle Assembly	56673-00200
15	Flat Washer	22562-01700
16	Bevel Gear (1 6 Teeth)	57987-00100
17	Setscrew, 6-32 x 1/8	55230-16500
18	SpacerPost	57990-00100
19	Front Mounting Plate Assembly	58094-00100
20	Bushing, Snap-in	58016-00100
21	Collar, Reset Spindle	24925-00100
22	Reset Spindle	57994-00100
23	Bevel Gear (32 Teeth)	57988-00100
24	Bevel Gear (32 Teeth)	57988-00200
25	Round Head Screw, 8-32 x 3/16	55109-19400
26	Lockwasher, No. 8	55294-00800
27	Counter/Totalizer Assembly	57998-00200
28	Bevel Gear (32 Teeth)	57988-00100
29	Round Head Screw, B-32 x 3/8	55109-19700
30	Lockwasher, No. 8	55294-00800
31	Housing Base Assembly	58093-00100
32	Bolt, Hex. Head, 1/4-20 x 1 3/4	55030-11800
33	Dial	*57999-00000
34	Screw, 4-40 x 1/4	55168-11400
35	Flat Head Screw, 1/4-20 x 3/8	55068-27400
36	Lens and Bezel	56563-00100
37	Tetraseal	22559-01600
38	Housing Top Assembly	56564-00100
39	Tetraseal	22559-04200

* When ordering dial, specify unit of measurement.



Please see our website at
www.badgermeter.com
 for specific contacts.

Due to continuous research, product improvements and enhancements, Badger Meter reserves the right to change product or system specifications without notice, except to the extent an outstanding contractual obligation exists.



BadgerMeter, Inc.

P.O. Box 245036, Milwaukee, WI 53224-9536
 Telephone: (414) 355-0400 / (877) 243-1010
 Fax: (414) 355-7499 / (866) 613-9305
www.badgermeter.com