

Model PC100	Process Controller	Installation & Operation Manual
-------------	--------------------	---------------------------------



IMPORTANT !!!! Read this manual before attempting any installation, wiring or operation.

SERVICE INFORMATION	
(FILE MANUAL FOR FUTURE REFERENCE AND SERVICE)	
Serial Number _____	Date Installed ____ / ____ / ____
Service Line _____	Operator _____



SCOPE OF THIS MANUAL

The sections in this manual have been arranged in such a way that you can, step-by-step, install, program, operate and, when required, troubleshoot the instrument.

The PC100 has many features. However, for normal operation, you need to be concerned with only a few of them.

The **MAIN MENU** shows most of the procedures and functions that are normally implemented to properly operate the unit.

The **OPTIONAL MENU** lists procedures or functions that can be implemented but are not required.

The **COMMUNICATIONS MENU** should be referenced only if you are connecting the PC100 to a serial printer or to a computer or process controller.

OPERATION OF THE PC100

The PC100 is a batch controller. It will accept a signal input from the transmitter, scale it to the desired unit of measure, and send a signal to operate a valve, pump, alarm, motor, etc.

In addition, it can count the number of batches, totalize inventory, indicate rate of flow, provide high and low flow alarms and communicate with printers and computers.

Other features include "slow valve closing" compensation, batch size limit, fail safe shutdown, and programmable function disabling.

After all items of the **MAIN MENU** have been implemented, select and program those in the **OPTIONAL** and **COMMUNICATIONS MENUS**.

MAIN MENU

- Unpack and install the PC100	4
- Wiring procedures	4
- Assembly and installation of PC100XP	5
- Operation and programming of all functions	10
- Troubleshooting and reprogramming	18

WIRING

- Connecting pulse transmitters to the PC100	6
- Connecting single stage valves, two stage valves, pumps, motors, and alarms	7
- Connecting the AC or DC power	6

PROGRAMMING

- Scale factor to count in gallons, liters, etc.	13
- Decimal point to show fractions	12
- Count from zero up or from batch down to zero	12
- End of batch to stay at zero or to reset to batch size	13
- Programming the batch size	15
- Programming the prewarn or first valve stage signal	15

DISPLAYS

- Ten digit totalizer	10
- Instantaneous flow rate	10

COMMUNICATIONS MENU

- Wiring a serial printer to the PC100	9
- Wiring to host computer or process controller	9
- Wiring the remote Print command	9
- Selecting communications or totalizer output	17
- Programming the BAUD rate	17
- Assigning and ID number to each PC100	17
- Selecting information to be sent to the printer	17
- Selecting automatic print on STOP and/or START ..	17
- Selecting line print delay to match printer used	17
- Enabling "on line" message to be printed after a failure or power down	17

OPTIONAL MENU

THE FOLLOWING FUNCTIONS ARE OPTIONAL TO THE OPERATION OF THE UNIT.

OPTIONAL WIRING

- Connecting remote controls to START, STOP, RESUME, RESET COUNTERS and PRINT	8
- Connecting a printer	9
- Connecting to host computer/process controller	9
- Connecting alarms or remote totalizers	8

OPTIONAL PROGRAMMING

- Display FLOW RATE instead of BATCH COUNT	13
- LIMIT the batch size that can be programmed	15
- AUTORECYCLE to repeat batches automatically ...	15
- AUTOADJUST, to compensate for valve overrun	15
- CYCLE preset, to stop after a set no. of batches	15
- FAIL-SAFE will stop batch if pulses not sensed	12
- HI and LOW FLOW rate alarm setpoints	16
- FLOW ALARM on/off	16
- PREWARN signal duration	15
- DISABLE any combination of functions	14
- DISABLE START, STOP, RESUME	14
- Programming outputs for flow alarms or scaled pulse output or cycle count output	12
- Resetting the totalizer	16

HOW TO UNPACK, ASSEMBLE AND INSTALL THE PC100

Note: If damage to the shipping container is obvious, request that the carrier be present when the product is unpacked. All claims for equipment damage during transit are the sole responsibility of the recipient.

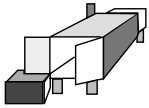

UNPACKING

After carefully unpacking the unit, check for any visible sign of damage. If found, notify the carrier for insurance purposes and call the factory for possible replacement. Keep all packing material in the event that the unit must be returned to the factory.



ASSEMBLY

The PC100 can be installed on the flowmeter, on a wall or shelf, or in an instrumentation panel. The picture below shows the exploded view of a meter or wall-mounted unit. In this configuration, the PC100 is shipped separately and must be installed as shown. (See wiring diagrams for proper transmitter signal connections.)

The basic unit is equipped for panel mount. To install:

- 1- Measure and cut mounting hole to the dimensions shown.
- 2- Install gasket around the mounting bezel.
- 3- Pass the unit through the front panel cutout.
- 4- Secure the unit to the panel with the mounting clips.
- 5- Complete wiring and reassemble unit.

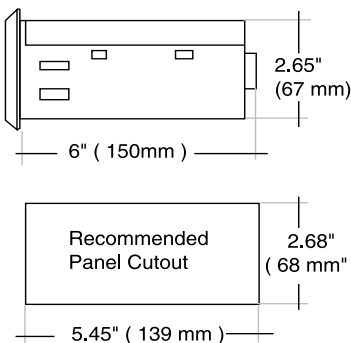
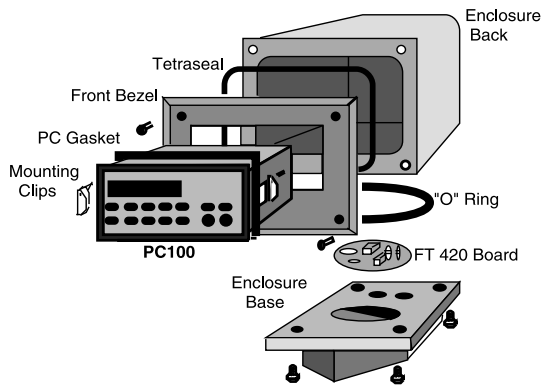

Note: Operating temperature is 32° F to 130° F (0° to 55° C) with a maximum humidity of 85% non-condensing.

Always select a mounting location with proper ventilation and environment protection.

HOW TO WIRE THE PC100

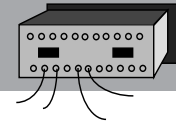

The rear panel of the PC100 controller contains 36 screw terminals for connecting #28 to #18 gauge insulated wire (#18 gauge stranded twisted pair shielded cable is recommended.)

A wire stripper and a small screwdriver are the only tools required. Detailed diagrams in this section illustrate the proper wiring procedures for all standard and optional functions.

At installation, be sure to comply with the following requirements:

- Disconnect power to the unit before attempting any connection or service to the unit
- Avoid using machine power service for AC power. When possible, a dedicated or lighting circuit is recommended
- Do not bundle or route signal lines with power lines
- Keep all lines as short as possible
- Use twisted pair shielded wire for all input wiring
- Observe all applicable local electrical codes

Terminal Identification List

No	Function	No	Function
1	Reset Cycle Counter	19	DC Power Input
2	Resume Remote Input	20	15 VDC Power Output
3	Stop Remote Input	21	DC Common
4	Reset Totalizer	22	Relay K1 Contact NC
5	Transistor Output 1	23	Relay K1 Contact C
6	Transistor Output 2	24	Relay K1 Contact NO
7	Transistor Output 3	25	AC Power Input
8	Transistor Output 1A	26	AC Power Input
9	Transistor Output 2A	27	AC Power Input
10	Transmitter Input 2	28	AC Power Input
11	Low Frequency 2	29	Relay K2 Contact NC
12	DC Common	30	Relay K2 Contact C
13	Low Frequency 1	31	Relay K2 Contact NO
14	Transmitter Input 1	32	Chassis Ground
15	Function Inhibit	33	Serial Data Input (-)
16	Print Command	34	Serial Data Input (+)
17	Start Command	35	Serial Data Output (+)
18	Pulse Input Doubler	36	Serial Data Output(-)

CAUTION: To prevent accidents, power connection should

Note: K1 relay coil jumper is factory wired to terminal 8. K2 relay coil jumper is factory wired to terminal 9. At the end of the batch, transistor outputs 2 and 2A (terminals 6 and 9) are energized. At prewarn, terminal outputs 1 and 1A (terminals 5 and 8) are energized.

HOW TO ASSEMBLE AND INSTALL THE PC100XP

This section deals with the procedures and recommendations on how to install Badger's PC100XP electronic batch controller in hazardous locations.

Except for the assembly and installation procedures, all other instructions are identical to the standard PC100 and should be referred to in this manual.

DESCRIPTION

The PC100XP is a standard batch controller mounted in an explosion proof enclosure. The enclosure is FM approved for CLASS 1, DIVISION 1, GROUPS C & D and CLASS II, GROUPS E, F & G environments. The enclosure complies with CSA and UL standards. It is also rated for NEMA 3, 4, 7 & 9 service (watertight).

OPERATION

The operation of the PC100XP is identical to that of the PC100 controller. On the PC100XP model, programming of functions and control commands is done mechanically through explosion proof push buttons.

Note: To prevent accidental or unauthorized tampering, deactivate all programming or command functions (except for those required during production operation) using function #41.

UNPACKING

The PC100XP is shipped from the factory disassembled. The standard PC100 and the XP enclosure are shipped separately to facilitate installation and wiring.

ASSEMBLY

ALWAYS FOLLOW LOCAL CODES AND MANUFACTURER'S INSTRUCTIONS WHEN INSTALLING THIS AND OTHER TYPES OF EQUIPMENT IN HAZARDOUS ENVIRONMENTS.

Note: Operating temperature is 32° F to 130° F with a maximum humidity of 85% non-condensing. Select a mounting location with proper ventilation.

Warning: To prevent the danger of electrical shock or explosion, turn off the power in any circuits that may introduce power to the wiring during the installation of this controller.

STEP-BY-STEP INSTALLATION

The following step-by-step installation instructions should be regarded only as a guideline for proper installation. Local codes or practices may require additional functions to be performed in order to assure safety of installation and operation.

1. Using a 1/4" allen wrench, remove the cover bolts from the front cover. Carefully place the cover over a level surface.
2. Unscrew the mounting plate screws and remove the Mounting plate.

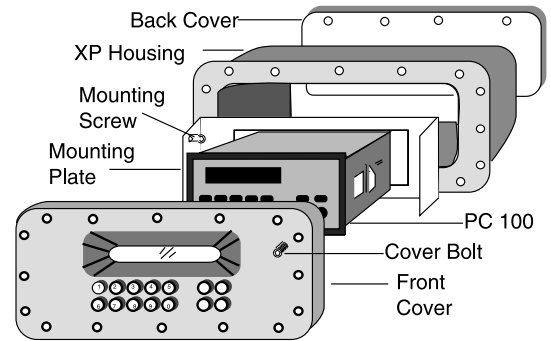

3. Open the PC100 carton and remove the unit. Use the enclosed mounting clips to mount the PC100 to the mounting plate.
4. Using the bottom and/or side tapped holes, mount the XP housing onto a firm platform, cabinet or the wall.

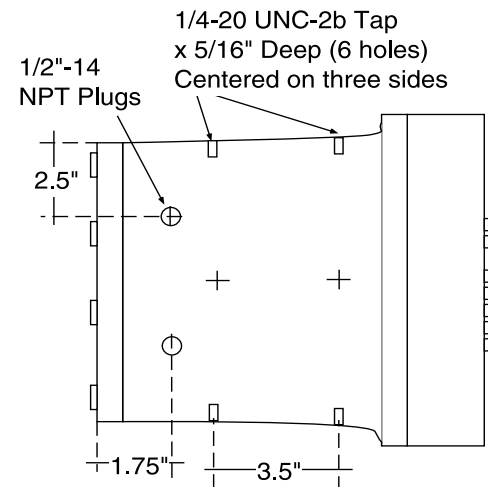
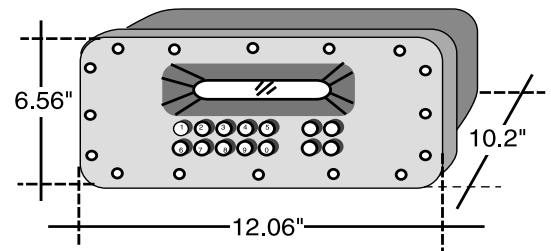

Upon completion of all wiring, tightly close all enclosures within the system.

Before applying power to the system:

- All electrical connections must be secure.
- All seals must be properly poured and completely cured and their seal fittings tightly closed.
- All joints in the conduit run must be tight.
- All enclosures in the system must be tightly closed.

Apply power to the controller and test operation in a manner that is suitable for the particular application. Exercise extreme caution!

For technical assistance during or after installation, please call our sales department or contact the Badger Meter representative in your area.

HOW TO CONNECT THE PC100 TO AC OR DC POWER

CAUTION: To prevent accidents, power connection should be made only after all other connections have been completed.

The PC100 is a microprocessor controller. It is important that the power supply be as "clean" as possible. Avoid using power lines that feed heavy loads such as pumps, motors, etc.

If dedicated lines are not available, a filtering or isolation system might be required.

120 volts connection

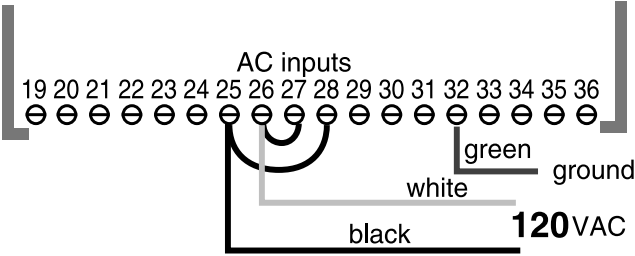

It is recommended that fuse protection be installed. Use a 2/10th amp slow blow fuse on 120 VAC and a 1/10th amp slow blow fuse on 240 VAC supply.

240 volts connection

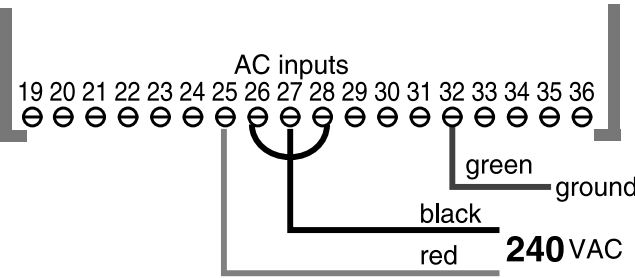

Typical US electrical code identifies the black wire as the hot or hi lead, the white wire as the low or neutral lead, and the green wire as the chassis ground lead.

For 240 VAC operation:

USA	Europe
Black	Blue
Red	Brown
Green	Green/yellow

11 to 16 VDC connection

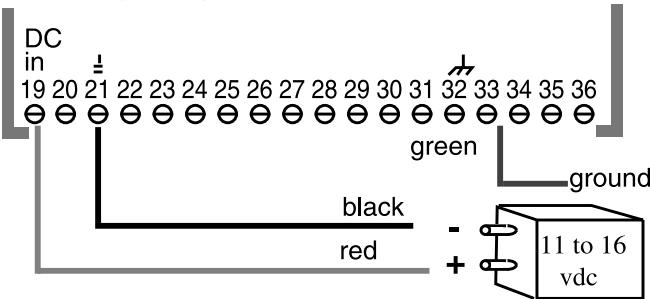

DC supply for mobile operation or as a backup supply can be done with a battery or other DC supply of 11-16 VDC/1amp.

Note: DC supply will not be available from terminal #20 when powering the unit with DC current.

HOW TO CONNECT SIGNAL TRANSMITTERS TO THE PC100

The following diagrams show how to wire most of the flow transmitters supplied with Badger Meter flow meters. Connection of transmitters from other manufacturers is similar. This section deals with pulse outputs generated by reed switches and by current sinking open collector transistors, the most common types of outputs found in flow meter pulse transmitters.

Note: A jumper between terminals #12 and #18 will double the transmitter output frequency.

WARNING!! Transmitter lines carry very low power signals and are sensitive to external noise. Always use shielded cable and keep AC power lines away from signal lines. Do not bundle or route these together since this may cause erratic operation of the PC100. DO NOT ground the cable shield at the transmitter end.

• REED SWITCH TRANSMITTERS (Type A)

Reed switch transmitters close a contact to DC common. Switches of this type have outputs of less than 150 HZ and generate contact bounce.

Therefore, installation of a jumper between terminals #12 and #13 is required. This effectively filters the unwanted extra closures caused by contact bounce. (Jumper terminals #11 and #12 if using transmitter input 2 on terminal #10).

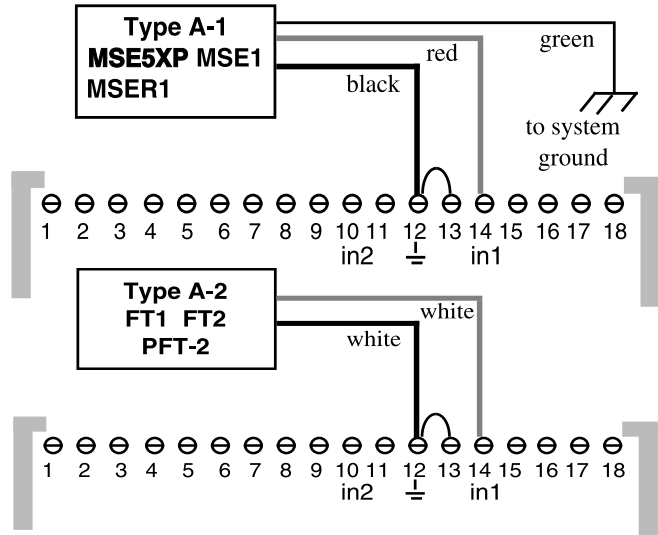

• EPT1XP & PEPT1 (TYPE B)

These models require that a special current regulator supplied with the transmitter be installed exactly as shown.

Reversing the polarity will damage the transmitter. No pulses will be detected without it.

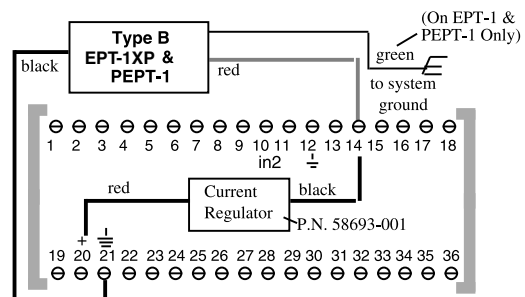

• OPEN COLLECTOR OUTPUT (Type C)

PFT2E, PFT3E, FT1E transmitters and meter mount PC100 sensors generate output signals from a current sinking NPN (open collector) transistor. The PC100 provides the necessary DC power from terminal #20 only when on AC main power.

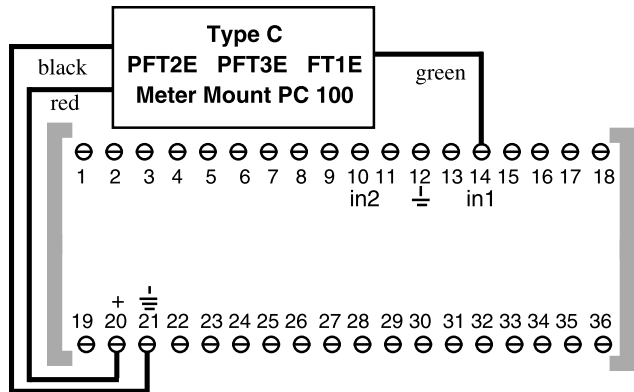

• FT420XP (TYPE D)

This transmitter has dual output, a 4-20 mA analog signal, and an unscaled open collector transistor pulse.

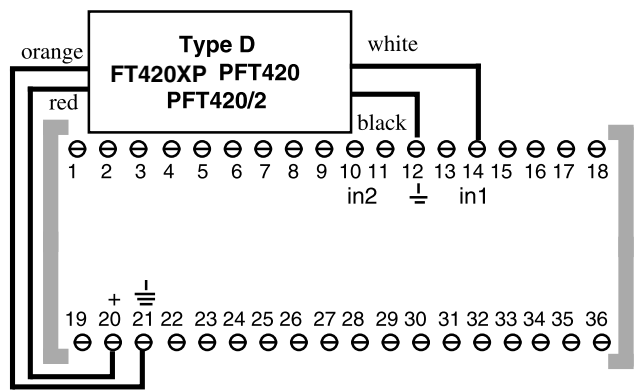

• PFT3 (TYPE E)

This transmitter consists of a Reed switch sensor which generates contact bounce. It is similar in operating to a Type A-2 transmitter.

Therefore, installation of a jumper between terminals #12 and #13 is required. This effectively filters the unwanted extra closures caused by contact bounce. (Jumper terminals #11 and #12 if using transmitter input 2 on terminal #10).

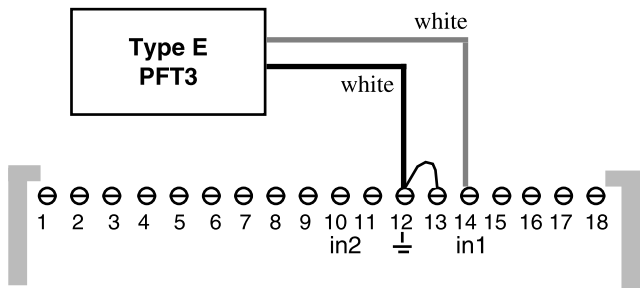

HOW TO CONNECT VALVES, MOTORS, PUMPS AND ALARMS

The following diagrams show how to wire the (2) relay outputs of the PC100. Each relay has a single set of form C contacts (one normally open and one normally closed). Relay outputs are typically used to energize or de-energize solenoids in valves, motors, pumps, and alarms.

CAUTION: Because the relays may be switching high power devices, DO NOT use the PC100 AC power supply to power valves or pumps. This might generate electrical noise and could damage the processor.

TYPICAL APPLICATIONS

• SINGLE STAGE VALVE CONNECTION

Always use Relay K2 when connecting to a single stage valve. At the preset batch point the relay will be de-energized, cutting power to the valve solenoid and causing the valve to shut off.

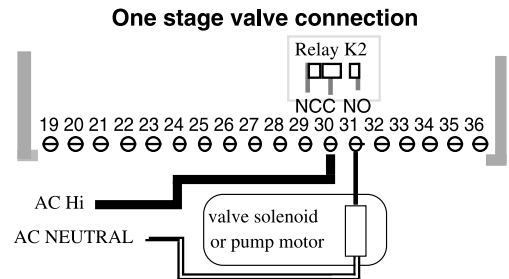

• MAIN PUMP CONNECTION

Relay K2 is connected to the pump motor to energize at the beginning of the batch and de-energize at the end. If used with a one stage valve, use Relay K1 and program prewarn to zero (0). (See page 15.)

• TWO STAGE VALVE CONNECTION

Relay K1 is connected to the first stage valve solenoid to partially close the valve and Relay K2 is connected to the second stage for final valve shutdown.

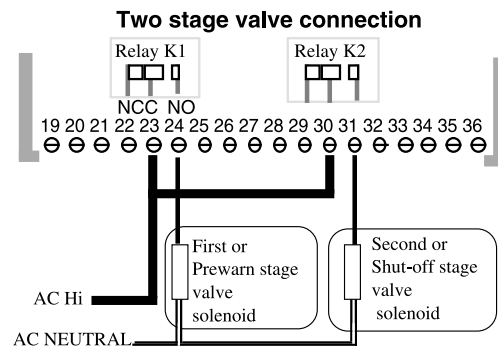

OPTIONAL APPLICATIONS

• FEED PUMP CONNECTION

Relay K1 can be connected to a feed pump to inject or add fluids to the main batch on a preset time basis. (Refer to F32)

• HI AND/OR LOW FLOW ALARM

Relay K1 can be connected to an alarm to provide a permanent or temporary warning signal when a low or hi flow preset point has been exceeded. To do this, move wire from terminal #8 and connect to terminal #7. See how to program the hi and low flow set points on page 14.

Alarm / feed pump / electric pump connections

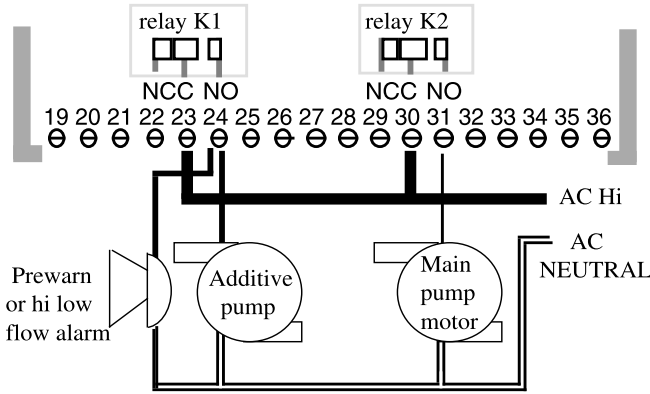

HI and LOW flow alarm

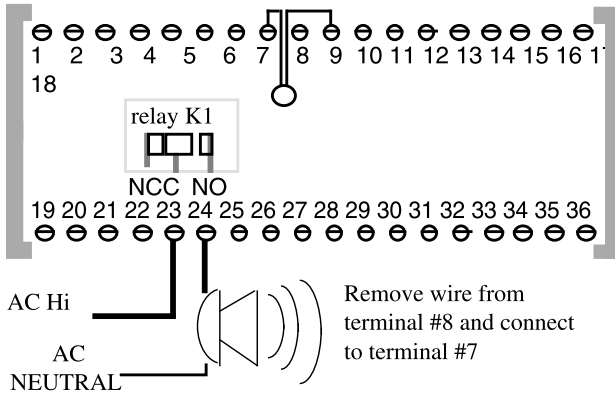

• RELAY PULSE OUTPUT

Relay K1 can also be used as a dry switch closure pulse output to operate devices such as remote counters or batch control panels (output frequency not to exceed 5 HZ.) To do this, move wire from terminal #8 to terminal #7.

See how to program pulse output duration on page 13.

Remote totalizer/cycle counter connections

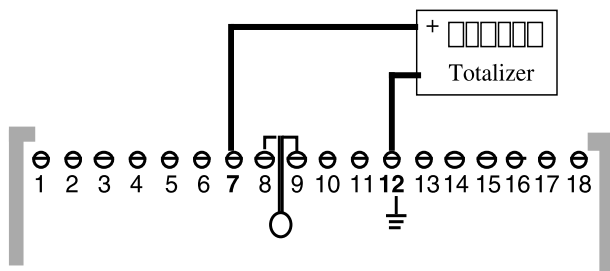

• BATCH COUNTER OUTPUT

Relay K1 can also be used to provide a switch closure at the end of each batch to a remote batch counter or other device. To do this, move wire from terminal #8 to terminal #7. See how to program cycle output on page 10. The transistor output on terminal #7 can be programmed for one of three functions:

- 1) To provide a scaled pulse output.
- 2) To provide a pulse at the end of each batch.
- 3) To provide a signal whenever the hi or low flow rate setpoints have been exceeded.

See function #33 for detail programming mode and technical brief for transistor output specifications.

Scaled Pulse Output: Generally used to drive an electronic remote counter or totalizer, or to interface with remote controllers. When using output in this manner you can select a pulse duration of 1 ms to 99 ms depending on the output frequency and the sensitivity of the receiving device.

End of Batch Signal: Can be used to totalize batches or cycle runs during a period of time, or to cascade several PC100s, so that one PC100 can start when the other finishes. This signal duration is adjustable.

• FLOW ALARMS

PC cascade connections

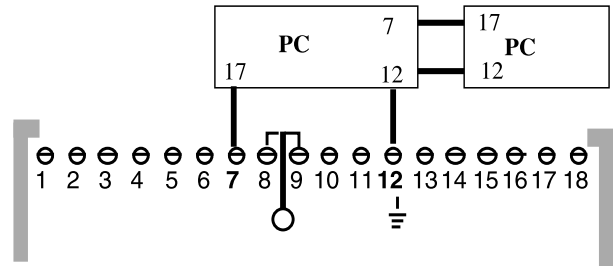

Used with a low powered piezoelectric or similar sounding device. It is energized when either the hi or the low flow setpoints have been exceeded and can be programmed to remain active until the end of the batch or to reset if the flow returns within preset limits.

Note: Transistor outputs #1 and #1A are de-energized the same as Relay K1, and transistor outputs #2 and #2A, the same as Relay K2. Therefore, these outputs can be used to drive external relays or other devices simultaneously with the batch and prewarn relay outputs.

Hi and low Flow Alarm connections

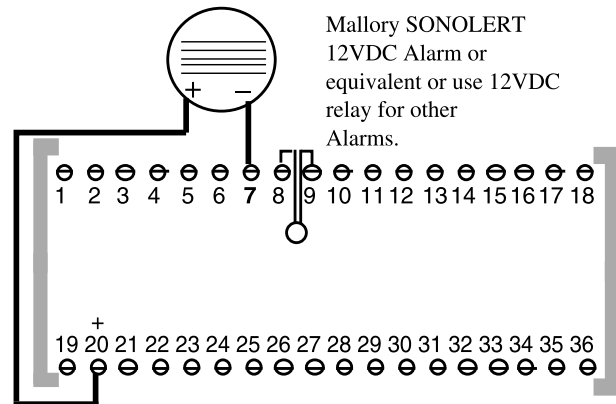

• START, STOP AND RESUME

These operations can be wired remotely for fast emergency override, or for cascading several units. If you inhibit these functions with function #41, only STOP and RESUME will still be operational with the remote control, START will not. If a sustained ground (DC common) is applied to the remote stop, all inputs are inhibited.

- The RESET CYCLE and RESET TOTALIZER are useful for end of shift coordination and control. Both inventory totalizer and cycle counter can be reset to zero.
- The PRINT input allows you to request printed information at any point during the operation, in order to inspect batch, flow, and inventory parameters.

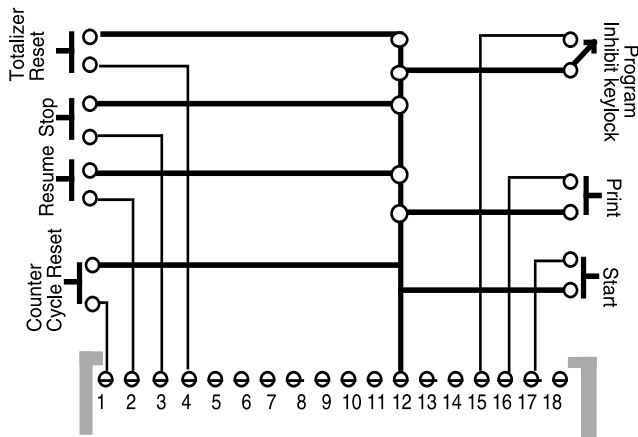

- The INHIBIT input allows you to connect a keylock or jumper in order to disable function #41, which lets you inhibit or uninhibit any or all functions.

• **CONNECT A SERIAL PRINTER**

The PC100 has terminals for serial input and output. The type of signal is a 20 mA data loop. The serial output can be used to transmit data to a serial printer. The input-output is used to connect a process controller for two way serial communication (transmit and receive.)

Commercial serial printers can be connected to the PC100 to receive and print flow information at the end or start of a batch or on command.

The connection to the PC100 requires that the printer be able to receive a 20 mA serial data loop or that a current to serial converter be used.

Always use twisted pair shielded cable for all serial communications. Keep cable as short as possible and do not place near power wires.

Function #66 may have to be programmed to the appro-

PRINTER CONNECTION

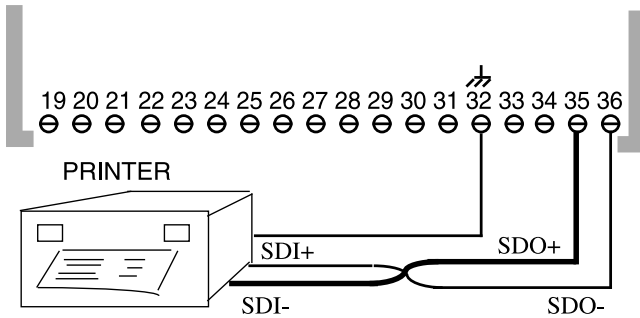

Always use twisted pair / shielded cable
 priate line print delay for the printer in use.

• **CONNECT A CONTROLLER**

The two way serial communication ports allow you to connect the PC100 to a process controller to send and receive data.

The connection requires that the host controller be able to accept a 20 mA data input. Otherwise, a 20 mA to RS signal converter must be used.

To connect more than one PC100 in series, first connect the 20 mA to RS transformer to the serial input of the computer. Then, connect the serial output to the first PC100 as shown. Thereafter, connect the serial output of one

PC100 to the serial input of the next unit.

Serial connection will be interrupted to all units if the power supply fails on any one of the PC100s. To prevent this from happening, you may want to connect a communications relay to each unit.

Wiring diagrams on how to connect the relay will be found in the relay packaging.

Up to 99 PC100s can be connected in this manner. Each unit sending and receiving information must be identified

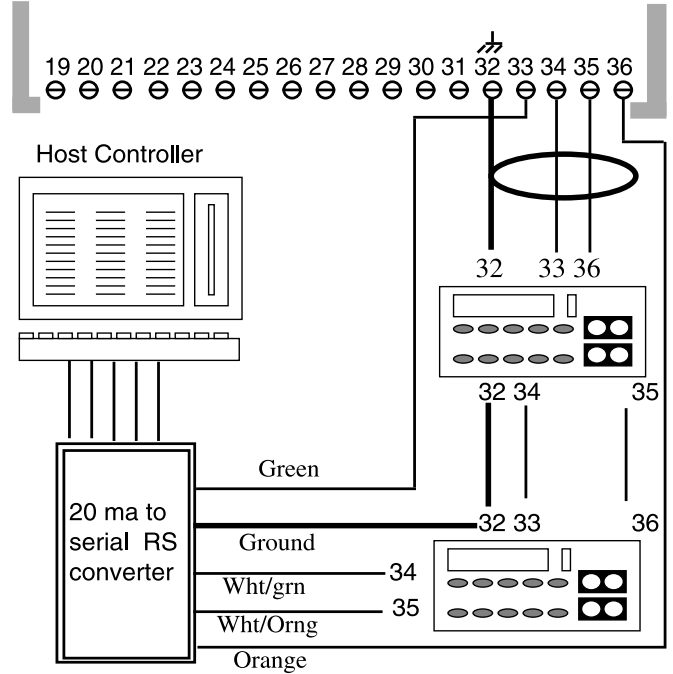

with an ID number. (See page15.)

The information below shows the parameters that can be reprogrammed by a host controller as "Information Received" and the parameters that the PC100 will transmit on print or interrogation as "Information Sent"

Information Received	Information Sent
P = Fixed Prewarn	Prewarn Setpoint
B = Batch Preset	Batch Setpoint
C = Cycle Preset	Cycle Setpoint
H = Rate High Setpoint	Rate High Setpoint
L = Rate Low Setpoint	Rate Low Setpoint
I = Print (Interrogate)	Scale Factor
F = Scale Factor	Totalizer Count
X = Stop Batch Count	
R = Resume Cycle Count	
S = Start Flow Rate	
V = Parameters That Vary (Counters and Flow Rate)	

• **SERIAL COMMUNICATION CHARACTERISTICS**

- Even parity transmission with no check for parity.
- On ID mode all characters are echoed and all lines must start with ID #. (ID number of PC100 to be interrogated.) Example: To change the batch from 150 to 180 on unit #3, you have to transmit #3B180*.
- When not on ID mode, characters are not echoed. All lines to start with line initial. Example: To change prewarn setpoint from 10 to 15, transmit P15*.
- If a line is accepted by the PC100, the * sign is changed to @. However, if a wrong line is sent to the PC100, an "INVALID REQUEST" message will be transmitted along with the unit ID #. If a wrong value is sent, such as prewarn larger than batch, a "VALUE ERROR"

HOW TO OPERATE THE PC100 PANEL



message will be transmitted.

The PC100 front panel consists of a display of six 7 segment LEDs, four yellow LED indicators, and a numeric/command keypad. Some of the number keys have dual function operation.

The panel provides watertight protection to the internal components and can easily be replaced in case of damage. A protective clear plastic cover is also available to protect the label from dirt, paint, puncture, or scratches (order part

To View Counters or Control Operation: Using the front panel you can view rate of flow, total and batch count, or start, stop and resume operation by simply pressing the keys so labeled.

To Program Functions: Press the function key, enter the function number, press the ENTER key to view the present value, change value, and press the ENTER key again to store the new value in memory. (See next page on programming sequence.)

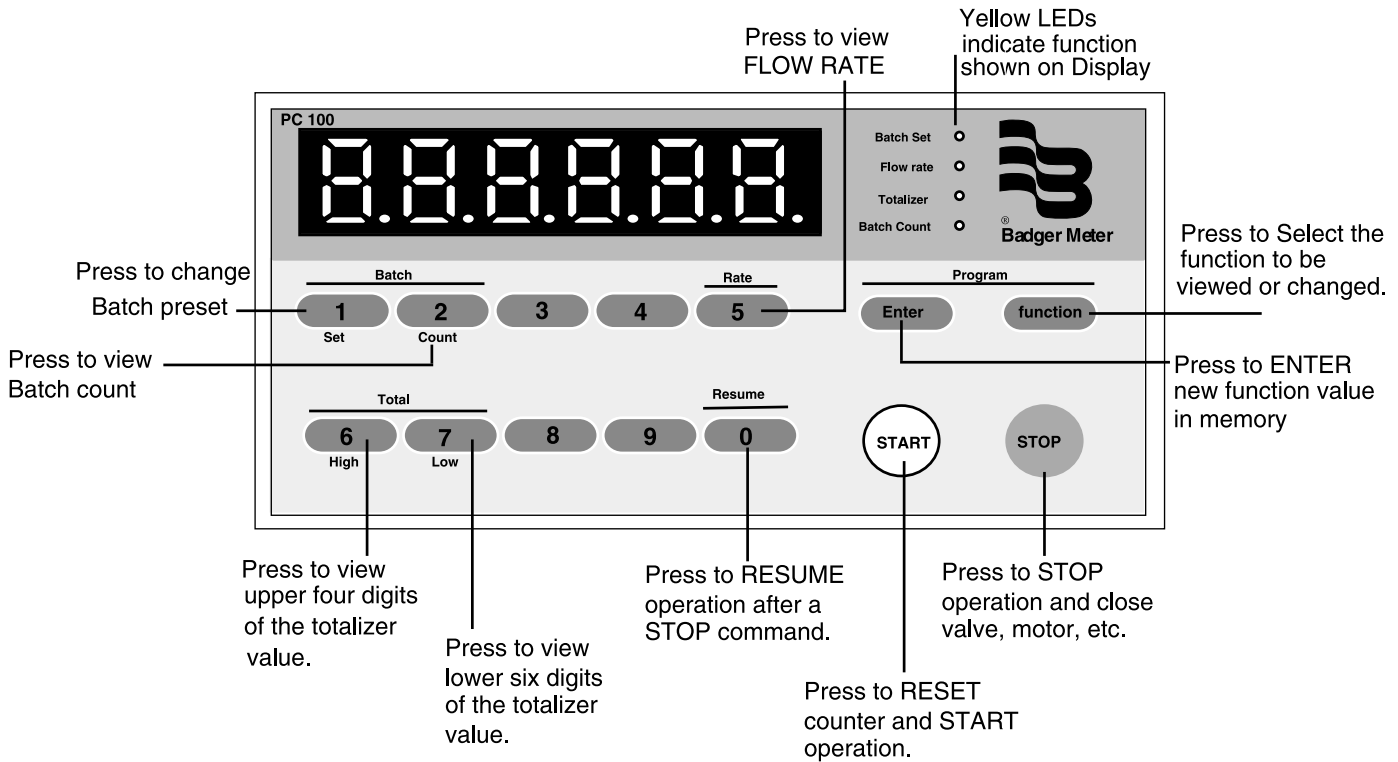

number 58689-001.)

DUAL PURPOSE FUNCTION KEYS

In addition to serving as numerical keys to program batch or other values, these keys can be used to program or display batch values, totals, and rate of flow

- 1 Set** The 1 key is used to program a new batch. Press once, enter the batch value, and press the ENTER key.
- 2 Count** The 2 key is used to return the display to batch count.
- Rate**
5 The 5 key is used to display the instantaneous flow rate in GPM, LPM, etc.
- 0 Resume** The 0 key is used to RESUME operation from the point where a STOP command was received.



START will reset the batch counter and energize both outputs to begin batch operation.



Press STOP to de-energize both outputs and to stop operation.

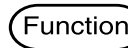

Press FUNCTION to start a program operation or to start over if a mistake is made.

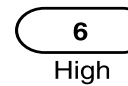

Press 6 to read the totalizer's four upper digits.

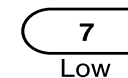

Press 7 to read the totalizer's six

HOW TO PROGRAM THE PC100

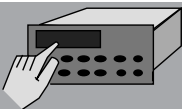

lower digits.

Programming the PC100 is very simple. Except for programming batch preset, all other functions are programmed the same way.

This section gives:

- Details on how to operate the front panel to program, step-by-step, each of the functions
- An explanation of the choices that are available for each function
- Examples to guide you over the critical functions

BASIC PROGRAMMING SEQUENCE

Example: Change the fail safe time between pulses from 2 seconds to 5 seconds.

- 1 Press the FUNCTION key.....
- 2 Press the function number 30.....
- 3 Press ENTER (display will show present value)
- 4 Press the new value.....
- 5 Press ENTER.....

FUNCTION	PAGE
*1 Batch Preset	15
10 Fixed Prewarn	15
12 Batch Limit	15
13 Batch Autoadjust (Learning Mode)	15
15 Cycle Preset (How Many Batches to Run)	15
16 Viewing Cycle Counter	15
*18 Scale Factor	13
20 Rate Period Units Per Second, Minute or Hour	16
21 Rate Low Setpoint	16
22 Rate Hi Setpoint	16
30 Fail Safe (Shutoff if Pulse is Not Received)	12
31 Autorecycle (Time Between Equal Batches)	15
32 Prewarn Timeout (Prewarn Signal Duration)	15
33 Output 3 Select (Cycle, Totalizer or Alarm)	12
34 Rate Mode Enable	13
35 Serial Output Select (Pulse or Information)	17
36 Pulse Output Width (1 to 99 ms)	13
37 Rate Output Latch	16

the PC100 is used as a batch controller.

As we mentioned at the introduction of this manual, many functions are available but only a few must be programmed for the proper operation of the PC100. The functions in this section are not presented in numeric order but instead in order of priority first, and second, in groups of similar operation, i.e., all batching functions, all rate functions, and all communication functions.

MUST

Functions that must be programmed will be marked with a symbol. Be sure that these functions are properly programmed.

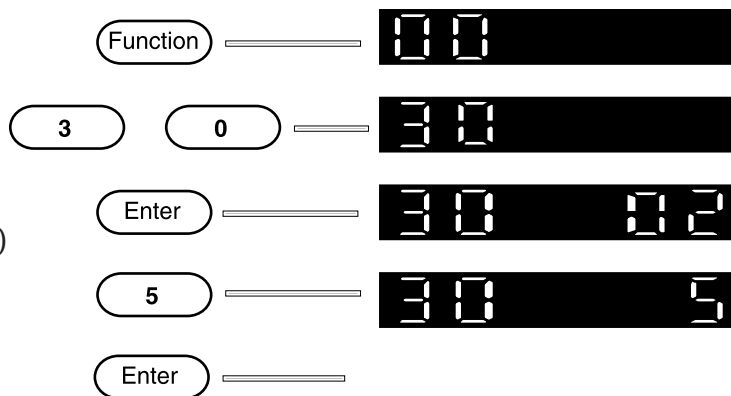

41 Enable/Disable Functions	14
42 Batch or Rate Display Default	13
43 Factory Default (All Functions)	14
44 Disable STOP	14
45 Disable RESUME	14
46 Disable START	14
*50 Count Mode (Up, Down, Quadrature)	12
*51 Reset or Preset	12
52 Totalizer Reset	16
53 Decimal Point Position	12
54 Cycle Counter Reset	16
60 Baud Rate Select	17
61 Print Data A Select	17
62 Print Data B Select	17
63 Print on START or STOP	17
64 Print on Command	17
65 Unit Identifier	17
66 Line Print Delay for Printers	17
67 On Line Message After Power Down	17

* These FUNCTIONS must be programmed when

SETUP FUNCTIONS

The display will show...

Once all wiring has been completed, the unit can be programmed for your application. Those functions marked "MUST" have to be programmed if the PC100 is being used as a batch controller.



Factory preset is 2

FUNCTION # 50: COUNT DIRECTION

This function allows you to program the way your transmitter input(s) will be counted in the display. Your choices are as follows:

- 0 - Input on terminal #10 will count up, input on terminal #14 will count down.
- 1 - Input on either terminal will count up.
- 2 - Input on either terminal will count down.
- 3 - Inputs on both terminals will count up in quadrature.
- 4 - Inputs on both terminals will count up in double quadrature.

Unless you are using quadrature transmitters, we recommend always using either code 1 to count up, or code 2 to count down in order to be able to use either input.



Factory preset is 1

FUNCTION # 51: RESET OR PRESET

After the count direction has been determined and programmed, you have to decide what the counter should show at the end of the batch. Your choices are as follows:

- 0 - If counting down, counter will stay at zero.
- 1 - If counting down, counter will go back to preset value.
- 2 - If counting up, counter will stay at batch preset.
- 3 - If counting up, counter will go back to zero.

Example: You may decide to count from the preset down to zero and at the end of the batch stay at zero so that you know that the batch was run. On the other hand, you may want the counter to reset to your batch value so that you may know what the batch was set at before starting a new batch.

Programming this function is important because once you press START the counter will immediately reset to zero on count up, or to batch size on count down, and start the operation. If you set the counter to stay at zero but would like to know what your batch is before the next operation, just press the 1 key and then the ENTER key.



Factory preset is 5

FUNCTION # 30: FAIL SAFE TIMEOUT

The pulse signal from the transmitter will be interrupted if the transmitter, the meter, the pump or other component fails. Enter 0 to turn off Fail Safe Timeout.

This function allows you to program a period of time from 1 to 99 seconds since the last pulse received. If a pulse is not received in this period, the outputs are de-energized and the operation is stopped. There is also a fixed fail safe following the start command, the operation is stopped.

Six zeros will flash to alert the operator of the failure. If a printer is connected, the message "B count NO CNT" will be printed.

To return the unit to normal operation after the problem has been solved, you must press the STOP key first.



Factory preset is 0

FUNCTION # 53: DECIMAL POINT POSITION

This function must be programmed if the scale factor was set up for fractions of a gallon, liter, etc. To program, simply enter the number of decimal points required on the display.

Example: If measuring in tenths of a gallon, then enter 1. If measuring in hundredths, then enter 2, and so on. The display will show 0.1, 0.02 and 0.003 respectively. The programmed decimal point will also appear in the totalizer and rate of flow indications.



Factory preset is 0

FUNCTION # 33: TRANSISTOR OUTPUT MODE

Program this function only if you plan to use the transistor output on terminal #7 for one of these three available options.

- 0 - **Totalizer Output.** This is a transistor scaled pulse output. It is usually used to connect to remote totalizers or process controllers. The pulse width can be programmed with function #36.
- 1 - **End of Batch Output.** This is a transistor output with a variable pulse width that is activated at the end of each batch. If connected to a remote counter, it can be used to totalize the number of batches run for a period of time (day, week, year or shift). If connected to terminal #17, a second PC100, it can be used to start

the second unit in order to cascade operations.

- 2 - **Hi and/or Low Flow Rate Signal.** If you program hi and low rate setpoints, this transistor output is activated when either setpoint is exceeded. The duration of this pulse is determined by programming function #37. Connect to a visual or audible alarm to alert you of irregular flow conditions.

Factory preset is 15ms

FUNCTION # 36: PULSE OUTPUT WIDTH

Program 1 to 99 ms. Certain electromechanical devices require wider pulse widths. Factory default is 15 ms which should be adequate for most applications. High frequency output pulses require narrower pulse widths.

Factory preset is 0

FUNCTION # 42: Default to BATCH or RATE DISPLAY

Normally, the PC100 is used to batch. Therefore, the display will always automatically return to batch count after a programming procedure (code 0). If the PC100 is used mostly for rate of flow indication, program code 1 and the display will return to flow rate instead of batch count.

Factory preset is 0

FUNCTION # 34: RATE MODE ENABLE

When this function is activated (code 1), the PC100 can only be used as a rate indicator and totalizer. All batch functions will be inactive. The display will default to rate of flow.

Factory preset is 1.0000

FUNCTION # 18: SCALE FACTOR CALCULATION

The transmitter sends out a finite number of pulses per gallon, liter, etc. In order to display these pulses in engineering units of measure, they must be “scaled” (multiplied by a constant.) Function #18 allows you to program this multi-

plier or SCALE FACTOR.

The table below shows the number of unscaled pulses for each gallon of liquid flowing through the listed Badger flow meters with selected transmitters.

If you want the PC100 to register in whole units, you must divide 1 by the unscaled pulses. Program the decimal point (function #53) for "0".

If you want the PC100 to register in 0.1 units, you must divide 10 by the unscaled pulses. Program the decimal point (function #53) for "1".

If you want the PC100 to register in 0.01 units, you must divide 100 by the unscaled pulses. Program the decimal point (function #53) for "2".

If you are scaling for any other unit of measure such as pounds, liters, ounces, etc., multiply the scale factor (in gallons) by the appropriate conversion factor.

Example: The unscaled pulses/gallon for a 2" OP meter with a PFT2E transmitter is 20.56. If you wish to read to the nearest 1/10 of a gallon, divide 10 by 20.56. The scale factor to read to the nearest 1/10 of a gallon would be 0.4864.

Note: If you are using a gear type scaled transmitter, or an electronic scaled transmitter, the PC100 scale factor should be 1.0000. In this case, the scaling is done by the transmitter.

Meter		Transmitter Pulses Per Gallon			
Size	Type	FT1	FT2XP	PFT3	PEPT1
		PFT2	PFT2E		
		PFT3E	PFT420		
1/2"	OP	222.96	445.92		1170.54
1"	OP	76.64	153.28		402.36
2"	OP	20.56	41.12		107.94
2"	Turbo	34.72	34.72	17.36	
3"	Turbo	24.80	24.80	12.40	
4"	Turbo	5.12	5.12	2.56	
6"	Turbo	2.16	2.16	1.08	
5/8"	25 lnd RCDL	198.40	396.80		1041.60
3/4"	35 lnd RCDL	126.67	253.34		665.03
1"	40 lnd RCDL	89.80	179.60		471.75
1"	70 lnd RCDL	46.80	93.60		245.70
1 1/2"	120 lnd RCDL	23.80	47.60		124.95
2"	170 lnd RCDL	14.56	29.13		76.46

ERROR CALIBRATION

To recalibrate the scale factor due to system error caused by meter wear or fluid viscosity changes, follow this procedure:

If necessary, modify the metering system so you can collect the fluid after it flows through the meter during the calibration procedure. You must be able to accurately weigh or measure the fluid that passes through the meter. Be sure there is sufficient back pressure to assure that the meter is always filled with fluid.

Program a batch value into the PC100 that is larger than the capacity of the vessel that will contain the fluid.

Push the START button on the PC100. Press the STOP button when the fluid nears the capacity of the vessel you are filling. Be careful not to overflow the vessel.

Accurately measure the fluid in the vessel. Observe the PC100 display, and determine the quantity of fluid delivered as determined by the PC100 reading.

Repeat the procedure two or more times to determine if you have repeatability. You cannot recalibrate unless you have repeatability. If your system is not repeatable, it is probably due to mechanical problems with one or more system components.

If your system is repeatable, use the following formula to determine the new scale factor:

$$\frac{\text{Quantity Delivered in Vessel}}{\text{Quantity Indicated on PC100}} \times \frac{\text{Old Scale Factor}}{\text{Factor}} = \frac{\text{New Scale Factor}}{\text{Factor}}$$

Use function #18 to enter the new scale factor into the PC100.

FUNCTION # 41: ENABLE, DISABLE FUNCTIONS

This function allows you to enable or disable the operation of any one or combination of functions in order to prevent accidental reprogramming or unwanted tampering of the unit.

Note: Wiring a jumper or keylock switch across terminals #15 and #12 will effectively restrict the use of this function. You will be able to view the functions by scrolling up or down but you will not be able to enable or disable them.

To operate this function, press: FUNCTION 41 ENTER. At this point, you will see the three digits to the right. The two digits to the left represent the function and the digit to the right of the decimal point is a 1 if the function is enabled or

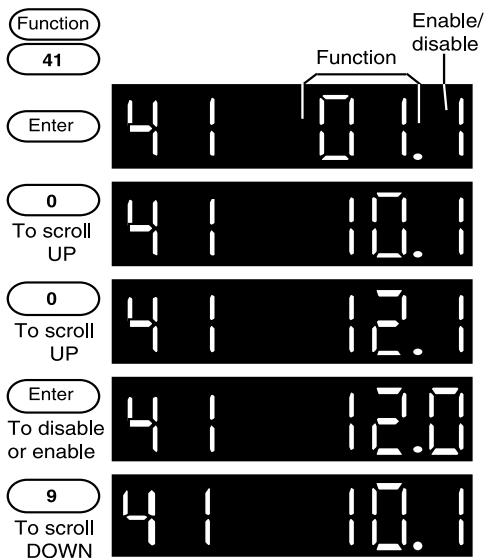

a 0 if disabled.

Press 0 to scroll up (functions 01.1, 10.1, 12.1....etc.) Release the key to stop at the desired function. To disable or enable that particular function, press ENTER. The first digit will then change from 1 to 0 or from 0 to 1.

To scroll down (functions 12, 10, 1, 67, 66, etc.), press key 9. Press 2 to return to batch count or FUNCTION to continue programming of other functions.



Factory preset is 0

FUNCTION # 44: DISABLE STOP

This function is used to disable the front panel STOP command. Disabling the front panel STOP prevents accidental stopping of the process. The remote STOP can be connected for supervised emergency STOP operation.

Program function #44 at 1 to disable. While disabled the STOP command can still be used to clear a FAIL SAFE condition (see function #30).



Factory preset is 0

FUNCTION # 45: DISABLE RESUME

This function is used to disable the front panel RESUME command. Disabling the RESUME command can prevent accidental restarting of a bad batch without supervision. This function can still be controlled remotely. Program the code to 1 to disable.



Factory preset is 0

FUNCTION # 46: DISABLE START

This function is used to disable the front panel START command. Program the code to 1 to disable. Once disabled, this function cannot be operated through the front panel nor remotely. Disable START only when using the PC100 as a nonresettable totalizer.



Factory preset is 0

FUNCTION # 43: FACTORY DEFAULT

Programming this function to 1 will reprogram all functions to the values set at the factory:

- #18 Scale Factor = 1.0000
- #20 Flow Rate In = Units Per Minute (1)
- #36 Totalizer Output = 15 ms (1)
- #50 Count Mode = DOWN (2)
- #51 Reset/Preset = Go to batch on down; go to zero on up
- #41 All Functions Enabled (1)

PROGRAMMING TO BATCH

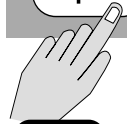
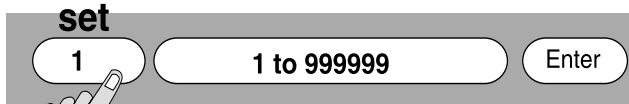

Factory preset is 0

MUST

FUNCTION # 1: PROGRAMMING BATCH AMOUNT

To program the batch, press 1, enter the batch value, and press ENTER.

If you just want to see what your batch is set at, press 1. Press ENTER to return to batch count.



Factory preset is 0

FUNCTION # 13: BATCH AUTOADJUST

0 - Batch Autoadjust Disabled. Totalizer input disabled at batch counter coincidence.

1 - Batch Autoadjust Enabled. The PC100 will compensate for any overrun at the end of the batch. Totalizer input is always enabled.

2 - Batch Autoadjust Disabled. Totalizer input always enabled.



Factory preset is 0

FUNCTION # 12: BATCH LIMIT

This function is used to program a limit to the size of batch that can be entered. This will prevent over batching.

Example: If the largest allowable batch in your operation is 255 gallons, then program the batch limit to 255 gallons.

Note: If the operator tries to enter a batch larger than the limit, when he presses ENTER, the display will revert back to the old value. Program to 0 if batch limit is not needed.



Factory preset is 0

FUNCTION # 31: BATCH AUTORECYCLE

If your operation consists of several batches of the same size, you can program the PC100 to start each batch automatically after a preset period of time (0.0 to 999.9 seconds). This is useful in container filling operations.



Factory preset is 0

FUNCTION # 15: CYCLE PRESET

If you are running several batches of the same size using the autorecycle feature, function #15 allows you to preset the number of batches to be run automatically. When the number of batches preset is reached, the unit will stop recycling and wait for another START command. The cycle counter is reset to zero at the end of the CYCLE preset.



Enter 2 to return to Batch Count

FUNCTION # 16: CYCLE COUNTER VIEW

Use this function to view the number of batches run since last reset. To reset the cycle counter to 0, use function #54 and program it to 1.



Factory preset is 0

FUNCTION # 10: FIXED PREWARN PRESET

Program this function to control the first stage of a two stage valve or for other prewarn functions (see page 7.) The preset point will be fixed. That is, if you program a prewarn of 5 gallons, the signal will be sent 5 gallons before the end of the batch. CAUTION: The prewarn setpoint must be LESS THAN THE BATCH SETPOINT or else six decimal points will light up and prevent further operation. To clear, press STOP and reprogram the prewarn setpoint.



Factory preset is 0

FUNCTION # 32: PREWARN TIMEOUT

Normally, when the prewarn setpoint has been reached, the relay K1 is de-energized until the batch is terminated. However, if the prewarn signal is used to control an alarm or a feed pump, the signal duration can be programmed from 1 to 99 seconds. Never use the time out if K1 is connected to the first stage of a valve.

PROGRAMMING FOR FLOW RATE



Factory preset is **1**

FUNCTION # 20: FLOW RATE PERIOD

This function is programmed to view the rate of flow in units per second, minutes or hours. Code 0 is for seconds, 1 is for minutes, and 2 is for hours. To view rate of flow, simply press key number 5. To return to batch count, press key number 2.

Note: Before programming the next two functions #21 and #22, make sure that function #33 is set for rate output.



Factory preset is **0**

FUNCTION # 21: LOW FLOW SETPOINT

Use this function to preset a minimum flow rate. If the rate falls below the setpoint, transistor on terminal #7 will be energized. On startup, the PC100 will wait until the minimum flow is reached before activating this function.



Factory preset is **0**

FUNCTION # 22: HI FLOW RATE SETPOINT

Use this function to preset a maximum flow rate. If the rate exceeds the setpoint, transistor on terminal #7 will be energized. Use the output to activate an alarm or other indication devices.

Note: Make sure that the Low setpoint is lower than the Hi setpoint. If not, the display will flash zeros, and if connected to a printer or computer, an ERROR message will be transmitted.



Factory preset is **0**

FUNCTION # 37: RATE OUTPUT LATCH

The choices are two; Code 0 will cause the output to stop if the rate returns to within the setpoints. With code 1, the output will not stop until the end of the batch or until you press STOP. The rate output can be connected to an alarm to indicate overflow or underflow conditions.

RESETTING COUNTERS



FUNCTION # 52: TOTALIZER RESET

Use function #52 to reset the totalizer to zero. The 10 digit totalizer on the PC100 has a capacity to totalize up to 9,999,999,999 (ten billion.) The totalizer must be reset to zero before this number is reached since the totalizer will not roll over automatically.



FUNCTION # 54: CYCLE COUNTER RESET

Function #54 allows you to reset the cycle counter (number of batches run) at any time. If function #15 is programmed to a preset number, the cycle counter is reset automatically when the preset number is reached. To reset, press FUNCTION-54-ENTER-1-ENTER.

SERIAL COMMUNICATIONS



Function 35 Enter 0 or 1 Enter

Factory preset is 0

FUNCTION # 35: SERIAL PULSE OR DATA

Program 0 to transmit and receive batch data or, program 1 to transmit only scaled pulses in serial form. When programmed to 1, all printer functions are disabled. Use code 1 only if the controller requires a pulse input instead of data.



Function 60 Enter 0,1,2 Enter

Factory preset is 0

FUNCTION # 60: BAUD RATE

This function must be programmed to match the communications speed rate of the printer or controller. Program 0 for 1200 baud, 1 for 300 baud, 2 for 110 baud.



Function 65 Enter 0 to 99 Enter

Factory preset is 00

FUNCTION # 65: UNIT IDENTIFIER I.D.

When connecting more than one PC100 to a process controller, program this function to assign an I.D. (1 to 99) to each PC100. The I.D. can then be used to channel communications from and to the host controller.



Function 66 Enter 0 or 1 Enter

Factory preset is 0

FUNCTION # 66: LINE PRINT DELAY

Printers often require different delay periods between lines of information transmitted. This function must be programmed to match the required line print delay of your printer. Program 0 for 0.1 second and 1 for 1 second.



Function 63 Enter 0,1,2,3 Enter

Factory preset is 0

FUNCTION # 63: PRINT ON START AND/OR STOP

Program 1 to print on START.
Program 2 to print on STOP.

Program 3 to print both on START and on STOP.



Function 64 Enter 1 Enter

FUNCTION # 64: PRINT COMMAND

Program 1 to print at any time. This function can also be operated remotely, at any time, with a switch connection between terminals #12 and #16.



Function 67 Enter 0 or 1 Enter

Factory preset is 0

FUNCTION # 67: MESSAGE ENABLE

Programming this function to 1 will cause the PC100 to send an "ON LINE" message to the controller or printer as soon as the power is restored after a power failure.



Function 61 Enter Y X Enter

Factory preset is 00

FUNCTION # 61: PRINT DATA SELECT A

Y select	X select
0= K SCALE - FL RATE	0 = INV - C COUNT - B COUNT
1= K SCALE	1 = INV - C COUNT
2= FL RATE	2 = INV - B COUNT
3= nothing	3 = INV
	4 = C COUNT - B COUNT
	5 = C COUNT
	6 = B COUNT
	7 = nothing

FUNCTION # 62: PRINT DATA SELECT B

Y select	X select
0= RTE HI- RTE LO	0 = S CYCLE - S BATCH-PREWARN
1= RTE HI	1 = S CYCLE - S BATCH
2= RTE LO	2 = S CYCLE - PREWARN
3= nothing	3 = S CYCLE
	4 = S BATCH - PREWARN
	5 = S BATCH
	6 = PREWARN
	7 = nothing

K SCALE = SCALE FACTOR
 FL RATE = FLOW RATE
 INV = 10 DIGIT TOTALIZER
 C COUNT = CYCLE COUNT
 B COUNT = BATCH COUNT
 HI= HIGH FLOW SET
 RTE LO= LOW FLOW PRESET
 S CYCLE = PRESET CYCLE
 S BATCH = PRESET BATCH

TROUBLESHOOTING THE PC100

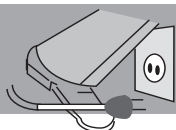

PREWARN = PRESET PREWARN

This section deals with most of the common problems that you may encounter with the PC100, the possible causes and the recommended remedies. Most of the problems are due to improper wiring and or programming procedures. However, the problem may originate in the flow meter, valve, pump, or

other piece of equipment.

Make sure other equipment is functioning properly. All PC100s are extensively tested at the factory before shipment. However, the units may get damaged during transit, installation, or errors in wiring. If after all possible solutions have been tried and the problem persists, contact your local representative or call our Industrial Sales Department at (414) 355-0400.

PROBLEM	POSSIBLE CAUSES	REMEDIES
Unit is powered but the display does not light up.	1. Incorrect AC or DC power wiring.	1. Recheck power wiring, fuses, etc.
Unit works fine but occasionally the display freezes up.	1. Line noise is affecting processor due to a current spike or surge.	1. Use dedicated power or install surge suppression network.
Transmitter is connected but the PC100 does not count.	1. Transmitter wiring is not correct. 2. EPT1 transmitter current regulator. 3. Transmitter is defective. 4. PC100 is defective. 5. Wrong scale factor. 6. Low frequency jumper for slow pulse input is connected.	1. Check wiring diagrams. 2. Install current regulator module. 3. Replace parts or whole. 4. To confirm, connect wire to terminal #12 and short to input terminals #10 or #14. Each contact should produce a visible count on the display when scale factor = 1. 5. Check scale factor calculation, i.e., if programmed .0001 instead of 1.0000, unit will wait for 1000 pulses before decrementing count. 6. Disconnect low frequency jumper from terminals #11 or #13.
Relays do not de-energize at setpoints.	1. Relays are not properly connected. 2. Relay is defective. 3. Connection between transistor outputs #8 & #9 and relay inputs are loose. 4. Relays are not plugged in all the way.	1. Reconnect relay wiring. 2. Replace relay. 3. Check connections. 4. Unplug and replug relays.
Counter accumulates too many counts.	1. Switch bounce causing extra pulses. 2. Electrical noise causing extra pulses. 3. Excessive vibration at meter.	1. Install low frequency jumper. 2. Check wiring. Be sure power lines are not bundled with signal lines. Use shielded wire. Connect ground to terminal 32. 3. Dampen vibration.
Some of the keys on the front panel are not operational.	1. Defective switches. 2. Unit is programmed to disable certain switch functions.	1. Repair or replace PC100. 2. Check programming functions.
Unit is operational but front panel has excessive wear.	1. Operator using sharp objects to program unit or certain keys are used too often.	1. Connect external remote switches to control frequently used functions and replace front panel.
Five decimal points light up on the display.	1. Prewarn setpoint is larger than batch size.	1. Reprogram preset points.
Cannot program batch size, display reverts back to old batch preset.	1. Batch size exceeds batch limit.	1. Reprogram smaller batch or deactivate batch limit.

PROBLEM	POSSIBLE CAUSES	REMEDIES
Cannot program preset points, rate time base, or scale factor.	1. These cannot be preset unless the unit is on a STOP condition. If you STOP and reprogram, you must START a new batch.	1. STOP unit and program. You cannot RESUME operation
Cannot program HI or LOW flow setpoints.	1. You have programmed Hi lower than Low.	1. Reprogram your setpoints.
The unit closes valves in the middle of a batch run and display flashes six zeroes.	1. Transmitter pulse has been interrupted and fail safe condition is active. 2. Fail safe period is too short.	1. Find reason of pulse interruption. STOP and reprogram fail safe period. 2. STOP and reprogram fail safe.
Pulse output connected to remote counter but it does not count.	1. Pulse width at 1 ms (too fast). 2. Reverse polarity.	1. Reprogram pulse width. 2. Check wiring with diagram.
Totalizer does not match sum of batches run.	1. Totalizer does not stop counting if autoadjust mode is active.	1. Check autoadjust function and also check for leaky valves.
Flow alarm remains on until end of batch instead of turning off when flow rate returns to normal.	1. Function #37 is programmed wrong.	1. Reprogram function #37.

You have now checked all the above mentioned procedures and the unit is still not functioning appropriately. There is the possibility that some internal component has been damaged and it is preventing normal operation. At this point, it is recommended that you run a diagnostic procedure using function #40.

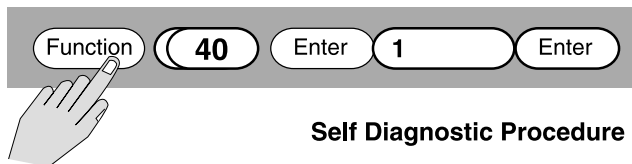

What this will do is put the PC100 into a self test of all memories and timers.

During self test all digits and decimal points will light up in ascending sequence. If a failure in the memory banks is detected, then a 4 will flash. If the timers fail, an 8 will flash and if there is a non-volatile memory failure, a 5 will flash. Normally, the malfunction can be corrected by using function #43, Factory Default, to make sure that all values are proper and then recycling power. Program each function again and test the unit in operation. If the malfunction persists, return the PC100 to the factory for evaluation.

Make sure to include a short description of the problem

so that we can test the unit for that specific condition.

CAUTION: There are no field replaceable parts inside. Opening the unit will void all warranties.

Note: Before returning the unit to the factory call your local representative or the factory to obtain a "Return Material Approval".

Carefully repack the PC100 in the original carton (or other suitable container) and ship to:

ATTN: Customer Service Department
"PC100 FOR REPAIR"
Badger Meter Inc.
4545 W. Brown Deer Road
P.O. Box 245036
Milwaukee, WI 53224-9536

1-877-243-1010



Please see our website at
www.badgermeter.com
for specific contacts.

Copyright © Badger Meter, Inc. 2009. All rights reserved.

Due to continuous research, product improvements and enhancements, Badger Meter reserves the right to change product or system specifications without notice, except to the extent an outstanding bid obligation exists.



BadgerMeter, Inc.

P.O. Box 245036, Milwaukee, WI 53224-9536
Telephone: (414) 355-0400 / (800) 243-1010
Fax: (414) 355-7499 / (866) 613-9305
www.badgermeter.com