



Badger Meter

Recordall® Cold Water Engineered Polymer Disc Meter

Size 5/8" (DN 15mm) NSF/ANSI Standard 61 Certified, Annex G

DESCRIPTION

Badger Meter offers a Recordall® Disc meter line that has been certified to comply with NSF/ANSI Standard 61, Annex G. All components within the Engineered Polymer meter, i.e., disc, chamber, housing, o-rings, etc., comprise the certified system.

APPLICATIONS: For use in measurement of potable cold water in residential, commercial and industrial services where flow is in one direction only.

OPERATION: Water flows through the meter's strainer and into the measuring chamber where it causes the disc to nutate. The disc, which moves freely, nutates on its own ball, guided by a thrust roller. A drive magnet transmits the motion of the disc to a follower magnet located within the permanently sealed register. The follower magnet is connected to the register gear train. The gear train reduces the disc nutations into volume totalization units displayed on the register dial face.

OPERATING PERFORMANCE: The Badger Meter Recordall Disc meters meet or exceed registration accuracy for the low flow rates (95%), normal operating flow rates (100 ± 1.5%), and maximum continuous operation flow rates as specifically stated by AWWA Standard C710.

CONSTRUCTION: The Recordall Disc meter construction, which complies with ANSI/AWWA standard C710, consists of three basic components: meter housing, measuring chamber, and permanently sealed register. The water meter is Engineered Polymer with externally-threaded spuds. A corrosion-resistant Engineered Polymer material is used for the measuring chamber.

To simplify maintenance, the register, measuring chamber, and strainer can be replaced without removing the meter housing from the installation. No change gears are required for accuracy calibration. Interchangeability of parts among like-sized meters also minimizes spare parts inventory investment.

MAGNETIC DRIVE: Direct magnetic drive, through the use of high-strength magnets, provides positive, reliable and dependable register coupling for straight-reading, remote or automatic meter reading options.

SEALED REGISTER: The standard register consists of a straight-reading odometer-type totalization display, 360° test circle with center sweep hand and flow finder to detect leaks. Register gearing consists of self-lubricating Engineered Polymer gears to minimize friction and provides long life. Permanently sealed, dirt, moisture, tampering and lens fogging problems are eliminated. Multi-position register simplifies meter installation and reading. Automatic meter reading systems are available for all Recordall Disc meters. All reading options are removable from the meter without disrupting water service.

TAMPER-PROOF FEATURES: Customer removal of the register to obtain free water can be prevented when the optional tamper detection seal wire screw or TORX® tamper resistant seal screw is added to the meter. Both can be installed at the meter site or at the factory.

MAINTENANCE: Badger Meter Recordall Disc meters are designed and manufactured to provide long-term service with minimal maintenance. When maintenance is required, it can be performed easily either at the meter installation or at any other convenient location. As an alternative to repair by the utility, Badger offers various maintenance and meter component exchange programs to fit the needs of the utility.

CONNECTIONS: Tailpieces/Unions for installations of meters on various pipe types and sizes, including misaligned pipes, are available as an option.



Model 25PN

SPECIFICATIONS

Typical Operating Range (100% ± 1.5%)	1/2 - 25 GPM (.11 to 5.7 m3/hr)
Low Flow (Min. 95%)	1/4 GPM (.057 m3/hr)
Maximum Continuous Operation	15 GPM (3.4 m3/hr)
Pressure Loss at Maximum Continuous Operation	4.2 PSI at 15 GPM (0.29 bar at 3.4 m3/hr)
Maximum Operating Temperature	80°F (26°C)
Maximum Operating Pressure	150 PSI (10 bar)
Measuring Element	Nutating disc, positive displacement
Register Type	Straight reading, permanently sealed magnetic drive standard. Remote reading or Automatic Meter Reading units optional.
Register Capacity	10,000,000 Gallons, 1,000,000 Cubic Feet, 100,000 m3. 6 odometer wheels.
Meter Connections	Available in bronze and Engineered Polymer to fit 5/8" (DN 15mm) spud thread bore diameter sizes. See table below.

METER SPUD & CONNECTION SIZES

Size Designation	x	"L" Laying Length	"B" Bore Dia.	Coupling Nut and Spud Thread	Tailpiece Pipe Thread (NPT)
5/8"	x	7-1/2"	5/8"	3/4" (5/8")	1/2"

MATERIALS

Meter Housing	Engineered Polymer
Housing Bottom Plate	Engineered Polymer
Measuring Chamber	Engineered Polymer
Disc	Engineered Polymer
Strainer	Engineered Polymer
Disc Spindle	Stainless Steel
Magnet	Ceramic
Magnet Spindle	Stainless Steel
Register Shroud	Engineered Polymer
Register Lid	Engineered Polymer or Bronze

PRESSURE LOSS CHART

Rate of Flow, in Gallons per Minute

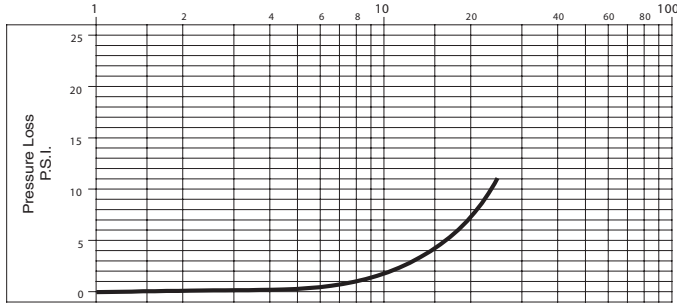

ACCURACY CHART

Rate of Flow, in Gallons per Minute

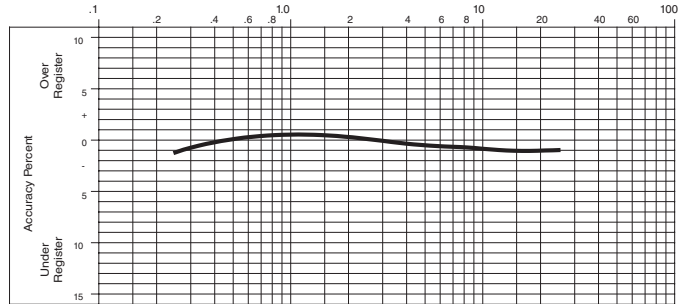

METER SIZE	METER MODEL	A LAYING LENGTH	B HEIGHT REG. / RTR	C HEIGHT GEN.	D CENTERLINE BASE	WIDTH	APPROX. SHIPPING WEIGHT
5/8" (15mm)	25PN	7-1/2" (190mm)	5-1/16" (128mm)	6-7/16" (163mm)	1-3/4" (44mm)	4-13/16" (122mm)	2-1/2 lbs. (1.0kg)

MODEL	GALLON	CUBIC FOOT	CUBIC METER
M25	10	1	.1/.01



Sweep Hand Registration

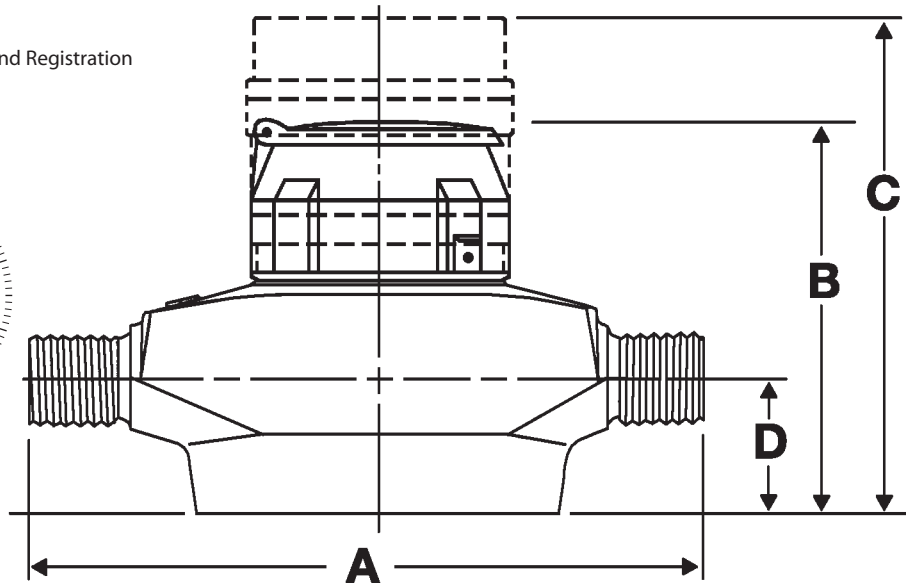
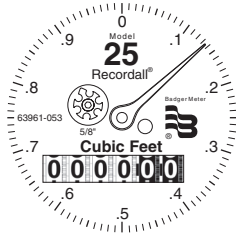
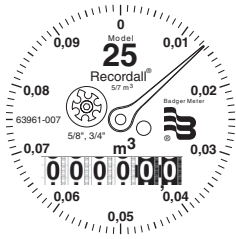

Recordall and RTR are registered trademark of Badger Meter, Inc.

Other trademarks appearing in this document are the property of their respective entities.

Copyright 2011, Badger Meter, Inc. All rights reserved.



Due to continuous research, product improvements and enhancements, Badger Meter reserves the right to change product or system specifications without notice, except to the extent an outstanding contractual obligation exists.