

Model FSAA-01

10" Model FSAA-01
FM Approved - 175 PSI Flanged
UL Listed, Fire Series Meter Assembly
with Strainer, Turbine Meter, Detector
Check Valve and By-Pass Meter

Technical Brief

DESCRIPTION

MODEL FSAA-01 FIRE SERIES METER ASSEMBLY consists of at least a six times open area strainer, a 10" Recordall® Turbo Series Meter with AWWA class II measuring chamber, a Check Valve with by-pass piping, valves, and a 2" Recordall Turbo Series Meter. The Fire Series Meter Assembly is designed to measure both low flow domestic use and high volume usage, such as when a building's fire sprinklers are activated, through a single water supply line.

INSTALLATION is made similar to placing a length of flanged end pipe in the line. The 175 lb. AWWA Class "D" steel flanged end design permits use in a wide range of applications. The meter must have a full flow of liquid for proper accuracy. It must be installed in horizontal applications only.

STRAINER is at least six times open area and is used exclusively in fire series systems to prevent clogging. The strainer is equipped with a 3" flushing port (optional valve) for flushing debris from the upstream side of the strainer screen.

TURBINE METER: Water flows into the meter's measuring element contacting the multi-vaned rotor. Flow readings are obtained by rotor revolutions transmitted by magnetic drive coupling through the meter's cover plate to the sealed register. Magnetic drive is achieved by a right angle worm drive, coupling the rotor to a vertical transmission spindle, driving a gear set rotating the magnet carrier. A ceramic magnet in a carrier rotates around a vertical axis. Rotor rotation is transmitted to the register gearing through this magnetic coupling.

The turbo measuring element is designed to greatly reduce wear by reducing friction potential between the moving parts of the rotor and bearing system. Less wear, in this critical area of the design, provides the utility manager with a lower life cycle cost for meter application. Throughout the normal operating range of the meter, the rotor floats between the thrust bearing system.

CHECK VALVE is a spring loaded check valve on the downstream side of the clapper to hold the clapper in a normally closed position. Small water flows by-pass the clapper and are registered on the 2" by-pass meter. This allows for accurate registration of domestic use, leakage or misuse of water intended for wet stand-by fire protection. When a major flow is required, the water pressure will overcome the mechanical advantages of the spring loaded clapper and push it open, permitting full pipe capacity flow during a fire emergency. A small amount of water will continue to flow through the by-pass when the spring loaded clapper is fully open.

BY-PASS LINE consists of piping with a 2" Recordall Turbo Series Meter, an isolation valve, and back flow preventing check valve.

SPECIFICATIONS

TYPICAL OPERATING RANGE (100% ± 1.5%)	4-7000 GPM.
MAXIMUM OPERATING PRESSURE	175 PSI.
MAXIMUM OPERATING TEMPERATURE	120° F (49° C)
TYPICAL LOW FLOW (95% MIN.)	2.5 GPM.
MAXIMUM CONTINUOUS OPERATION	5500 GPM.
MAXIMUM INTERMITTENT FLOW	7000 GPM.

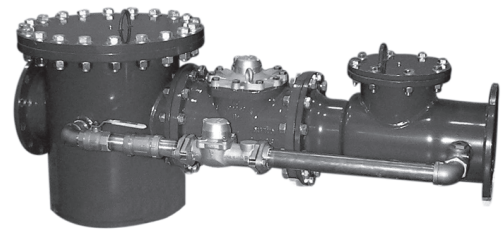

MATERIALS

NOSE CONE AND STRAIGHTENING VANES	thermoplastic
ROTOR	thermoplastic
ROTOR RADIAL BEARINGS	lubricated thermoplastic
ROTOR THRUST BEARINGS	sapphire jewels
ROTOR BEARING PIVOTS	passivated 316 stainless steel
CALIBRATION MECHANISM	stainless steel and thermoplastic
MAGNET	ceramic
REGISTER LID AND SHROUD	thermoplastic, bronze
TRIM	stainless steel
STRAINER SCREEN	stainless steel
BY-PASS MEASURING CHAMBER	injection molded thermoplastic
TURBINE SHAFTS & BOLTS	stainless steel
METER HOUSING	fusion bonded epoxy coated ductile cast iron
BY-PASS METER HOUSING	cast bronze (B81), Low Lead Alloy (LL)
CLAPPER	stainless steel
CLAPPER SPRING	stainless steel
CLAPPER HINGE & PINS	stainless steel
CLAPPER SEAL	elastomer, EPDM
VALVE SEAT	cast brass
VALVE & STRAINER COVER PLATE	fusion bonded epoxy coated steel
VALVE & STRAINER COVER PLATE GASKET	elastomer sheet
VALVE BUSHINGS	brass
BY-PASS	Water works brass piping conforming to AWWA C800
VALVE BODY	Stainless steel, coated inside and out with fusion bonded epoxy. Standard flange connections (ANSI B16.1)
STRAINER SCREEN	stainless steel
STRAINER BODY	fusion epoxy coated steel
OPTIONAL EQUIPMENT	Includes transmitters with remote read capabilities, companion flanges, and various pipe sizes are available in CI or bronze.
SHIPPING WEIGHT	1073 pounds shipped fully assembled.
CERTIFICATION	Valve conforms to UL 312 and FM 1045. Fire Series Meter Assembly conforms to UL 327, FM 1044 and AWWA C703. Strainer conforms to UL 321 and FM 5551. Strainer open area is at least six times the area of the nominal pipe size. Meter measuring chambers are AWWA class II.
ORDERING INFO	Must be specified by the customer and includes: Size, minimum & maximum flow range, totalizer dial units, optional equipment desired. Standard side for by-pass meter is right hand (shown above) unless specified otherwise.



BadgerMeter, Inc.

FSAA-T-10

10" MODEL FSAA-01

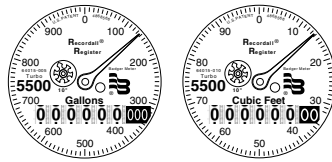

Mainline Registers

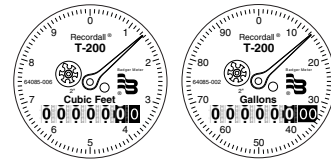

By-Pass Registers

PRESSURE LOSS CHART

CONSISTS OF CAST IRON TSM MAINLINE, BRONZE 2" TSM BYPASS,
 WITH AMES SHORT STRAINER AND CHECK VALVE
 RATE OF FLOW IN GALLONS PER MINUTE

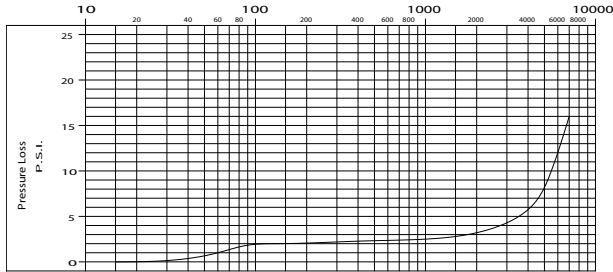

ACCURACY CHART

CONSISTS OF CAST IRON TSM MAINLINE, BRONZE 2" TSM BYPASS,
 WITH AMES SHORT STRAINER AND CHECK VALVE
 RATE OF FLOW IN GALLONS PER MINUTE

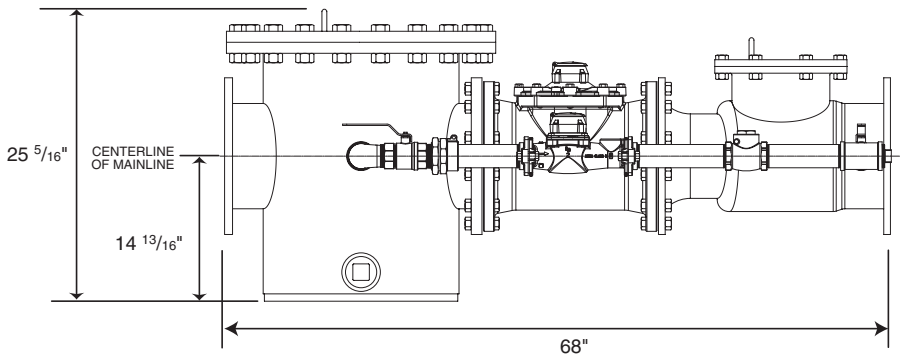
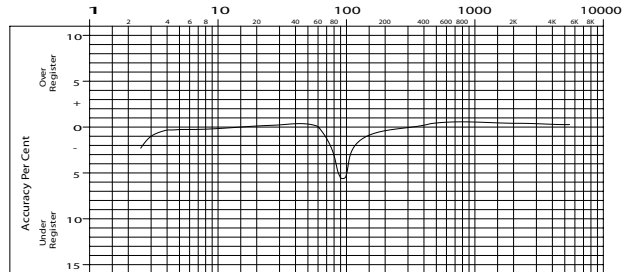
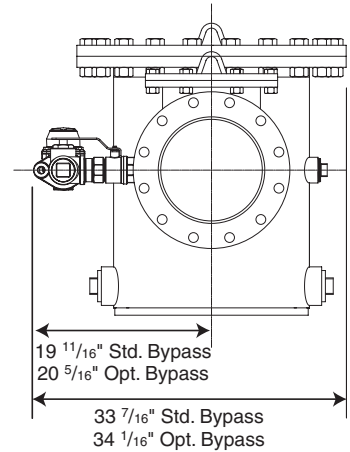

Illustration includes optional 2nd shutoff valve on bypass.



Recordall® is a registered trademark of Badger Meter, Inc.



Please see our website at
www.badgermeter.com
 for specific contacts.

Copyright © Badger Meter, Inc. 2006. All rights reserved.

Due to continuous research, product improvements and enhancements, Badger Meter reserves the right to change product or system specifications without notice, except to the extent an outstanding contractual obligation exists.



BadgerMeter, Inc.

P.O. Box 245036, Milwaukee, WI 53224-9536
 (800) 876-3837 / Fax: (888) 371-5982
www.badgermeter.com