

Model RET™

**Recordall® Electronic Transmitter
Providing Unscaled, Scaled &
Optional 4-20 mA Outputs**

Installation & Operation Manual



***This Product Contains Lithium Batteries.
Read This Manual Before Attempting Any Installation,
Wiring or Operation.***

Scope of this manual

This manual contains information concerning the installation, operation and maintenance of the Badger® RET™ Recordall® Electronic Transmitter. To ensure proper performance, the instructions given in this manual should be thoroughly understood. Retain the manual in a readily accessible location for future reference.

Installation, operation and wiring of this unit is fairly simple and straight forward. This manual is designed so as to provide you with a step by step guide for this purpose.

Programming the unit is covered later in this manual and requires a personal computer, a programming interface unit

and special software. The latter two can be purchased from Badger Meter if required.

The examples provided are only to facilitate an understanding of the functions of the product. Your specific application will most likely have a different set of values.

The troubleshooting section attempts to illustrate the most common problems that can be encountered, their most likely cause and the recommended solution. If a problem persists, please contact our technical support group at:

Badger Meter, Inc. Customer Service
1-800-876-3837

General Information

The Recordall® Electronic Transmitter (RET™) is designed for use with all Recordall Disc, Compound and Turbo Series meters as well as Turbo II meters to provide output compatibility with standard industry instrumentation devices.

The RET is equipped with an LCD digital display that can be calibrated in either gallons, cubic feet, cubic meters, liters or imperial gallons. Using a magnet the product allows the user to toggle between the different displays of totalization, flow rate, reverse flow, and other meter specific information.

The Recordall Electronic Transmitter is offered in two product versions. The standard RET unit comes complete with

both a scaled open collector and unscaled open collector output signal. The product is also offered with an optional 4 to 20 mA output providing a rate of flow signal.

The Recordall Electronic Transmitter is field programmable allowing the unit to be calibrated remotely and interchanged with other Badger Meter products. An internal lithium battery is used to power the display. The 4 to 20 mA option requires additional external power for operation.

The RET is designed to be totally submersible. Connection is made via a waterproof connector cable available in various lengths.

Specifications

Transmitter/Register	Liquid crystal display, permanently sealed, magnetic pick-ups, multiple outputs, water proof connection
Liquid Crystal Display	Six digits with 1/4" numerals
Weight	13 Ounces
Humidity	0% to 100% Condensing
Operating Temperature	-10 to 60°C (14 to 140°F)
Unit of Measure	U.S. Gallons, Cubic Feet, Cubic Meters, Liters, Imperial Gallons clearly identified on LCD display
Rate of Flow	Units per Minute or Units per Hour
Rate of Flow Response	6 seconds when flow rate is 10% to 100% of maximum flow. Response time is programmable when flow rates are < 10% of maximum flow.
Test Mode Totalization	1/1000th of totalization display
Backflow Totalization	1/1000th of totalization display
Internal Power Source	One lithium, 2.4 A hr. battery
External Power	9.0V 0- 50VDC (required to use optional 4-20 mA output) max loop resistance = 50 Ohms + 50 Ohms (Vsupply - 9V)
Electrical Criteria	Immunity to electrical surges and transient per IEC 1000-4-2 & IEC 1000-4-4.
FCC Compliance	FCC Part 15 Subpart J
Signal Characteristics	Open Drain (FET)
Resolution	Scaled is programmable with unscaled fixed for the individual meter
On State Resistance	<50 Ohms @ 25°C (77°F) for scaled output, <400 Ohm @ .1mA for unscaled output
Off State Resistance	>5 MOhms @ 25°C (77°F)
Power Source	Internal with External Option
Maximum Switching	30 VDC @ 1 mA @ 25°C (77°F)

Installation Instructions

The following instructions are to assist you in the connection process of the RET™. Keep all parts clean prior to assembly. Any dirt or water within the connector enclosure can cause corrosion of the contacts which will reduce connector life.

The RET is shipped with a protective cap to protect the female connector. To remove the cap place a screw driver in the slot of the locking band. Twist the screw driver until the ring breaks. Remove the ring and remove the cap from the female connector.

To connect the adapter, first apply grease from the small tube in the kit into the terminal cavity of the male connector. The tube contains the correct quantity of grease to use so be sure to dispense all of it into the connector. A pliers may be helpful to assist in squeezing out the last quantity of grease.

Connecting the Harness to the RET

1) Drop the locking band onto the female connector with the short alignment mark up and position the band so that the long alignment mark is lined up with the alignment mark at the base of the female connector.

2) Insert the male connector into the female connector, again lining up the long alignment marks on each component. The

insertion operation may require significant force to displace the excess grease from the connector cavity.

3) With the connector halves forced together, turn the locking band to align its short mark with the long alignment marks on the connector halves. Molded tabs on locking band and male connector will assist in this turning operation. When in the correct final position, you should hear a click indicating it is locked.

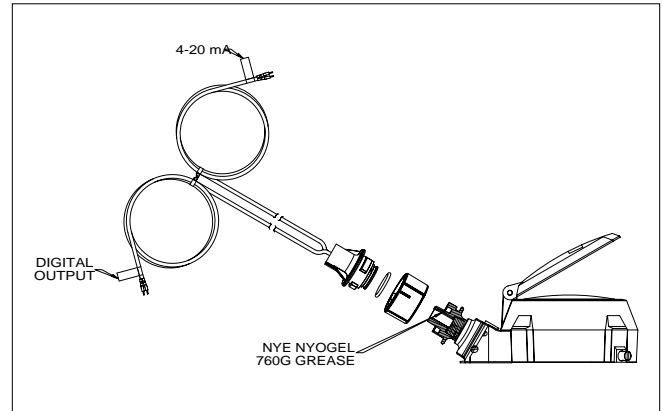

Wiring Diagram

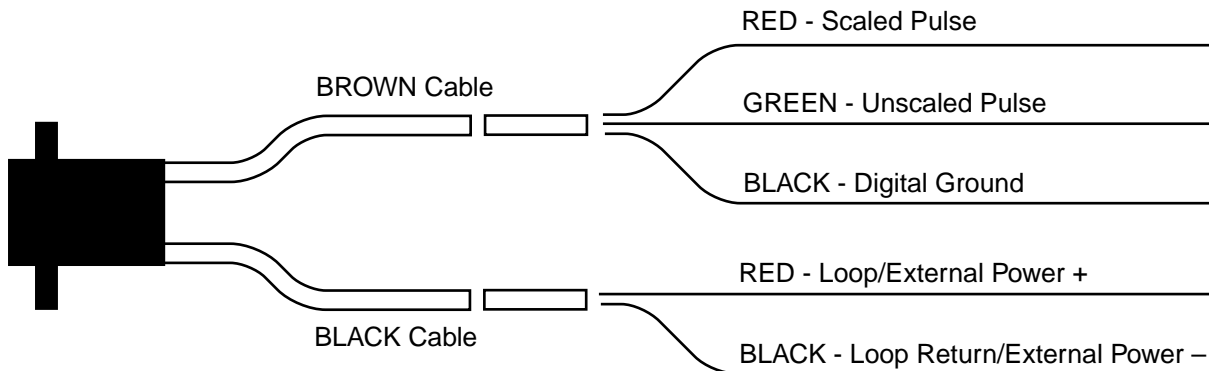

NOTE: To apply external power to an RET without the 4-20mA option, the 2-wire harness (BROWN and BLACK) shown above must be used. The BLACK cable is used to power the unit. See the External Power Specifications on page 2 for Power Requirements.

Operation

The RET™ is shipped pre-programmed with preset default values for the specific meter it will be used on or with specific values requested by the customer. In either case, the programmed values can be viewed on the display along with totalization and rate of flow values.

To view the seven different values on the display simply touch the programming magnet that came with the RET to the side of the register as shown in figure A below.

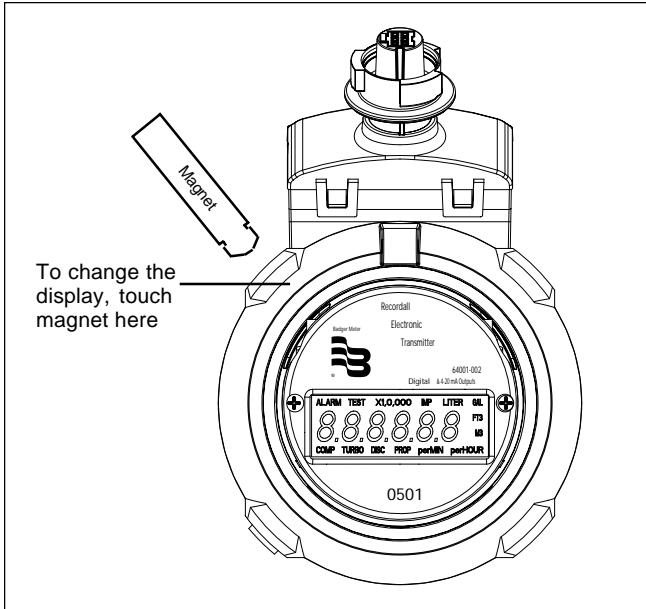

Figure A

The display will cycle through the following information “screens” when activated by an external magnet. During the activation process, there is a one second delay before the display can be advanced again. This delay is designed to avoid inadvertent skips in the visual display. The totalization and flow rate information are continuously updated as the display is being viewed.

Note: When the scaled output and 4-20mA flow rate outputs are not used the corresponding “screens” will not be shown.

1. totalization
2. rate of flow
3. meter type and size
4. high resolution test mode
5. back flow totalization
6. scaled pulse resolution
7. 20 mA set point

1. Totalization: Meter consumption is shown as a 6 digit number. Depending on the test circle value one of the multiplier values will also be shown (X10, X100, X100, X1,000, X10,000). If the test circle is less than 1 then a decimal point will be used. The unit of measure will also be displayed (GAL, FT3, M3, IMP, LITER).

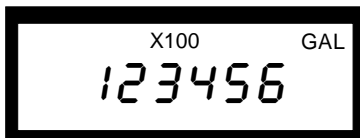

2. Rate of Flow: Rate is shown as a 5 digit display without a multiplier. The unit of measure (GAL, FT3, M3, IMP, LITER) will be shown with the corresponding time unit (per MIN, per HOUR). The flow rate resolution will vary with meter size. There are no multipliers used for flow rate. Flow in the reverse direction is displayed with a negative sign.



3. Meter information: This screen identifies the meter for which the transmitter was programmed. The information shown will be the meter type (TURBO, DISC, COMP), unit of measure (GAL, FT3, M3, IMP, LITER) and the 6 digit display that will uniquely identify the meter. Disc meters are indicated by a d, Turbo meters are indicated by a r and Compound meters are indicated by a C. The example below shows a 3" Turbo Series meter calibrated in gallons.



4. Test mode: This screen is identical to the totalization screen except for the resolution. The TEST annunciator is used to identify this mode. In the test mode the resolution is increased by a factor of 1000 to obtain accurate test results. For example, if the usage on the totalization screen 123456 gallons X 100 or 12,345,600 gallons then in the test mode the multiplier would move the display 3 decimal places to the right and show the actual values of the last three digits. The display would then show TEST 45678.9 GAL.



5. Backflow: This screen is identical to totalization except it is only 5 digits preceded by a negative sign. The negative sign indicates the backflow screen. The resolution of the backflow screen is the same as in the test mode. The backflow screen shows the total amount of reverse flow through the meter.



6. Scaled pulse resolution: This screen uses the unit of measure and the six digit display to show the amount of consumption that one scaled output pulse represents. A "P" is used to indicate this screen. The example below represents one pulse as equaling ten gallons.



7. 20 mA set point: This screen indicates the flow rate that represents 20 mA. An example of the screen is 20-450 GAL perMIN which represents 450 gallons per minute.



There is also an alarm screen. If an alarm occurs, the alarm annunciator and corresponding alarm code will be displayed prior to the totalization screen. In addition to the "alarm" annunciator, an "EC-" and a number will appear to indicate the problem.

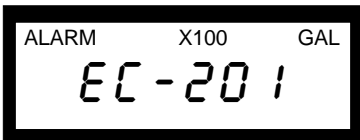

When an alarm occurs an error code displayed. The key for each alarm is the first number after the EC. Error codes are listed below. The XX represents other internal programming numbers.

Sensor Alarm:	EC-1XX
Battery Alarm:	EC-2XX
Back Flow Overflow	EC-8XX

The display will normally be in the totalization mode. The exception is in the case of an alarm condition. If an alarm occurs, the alarm screen will automatically be displayed in place of the totalization screen. Once the display is activated by the external magnet the totalization screen will be displayed and the normal sequence will resume with the alarm condition being shown after the totalization screen.

To clear the alarm condition apply power (9 Volts) to the black cable. Positive (+) to the red wire and negative (-) to the black wire. If these wires are being used to power the 4-20 mA loop turn the 4-20 mA power off then on again to clear the alarm screen from this display.

Two minutes after the last activation by the program magnet the display will automatically return to the totalization screen. If the display is reactivated after the two minute delay and the alarm condition still exists the first screen that will be shown is the alarm screen. Once a time-out occurs at any display step, the display returns to the totalization screen.

Programming Instructions

RET PROGRAMMER OPERATING INSTRUCTIONS

System Components:

The RET™ Programmer is an electronic interface circuit used to program and read the parameters of the Recordall® Electronic Transmitter (RET). The RET Programmer is powered by a standard 9 volt alkaline battery. Connection from the RET Programmer to the RET is accomplished through a cable assembly and plug that connects to the RET. The RET Programmer is controlled by a PC (via a serial port) using a standard straight-through 9-pin cable. The PC requires a Windows operating system and the RET Programmer software. The software provides an easy-to-use graphical interface for setting the parameters for the RET.

Software Installation:

1. Insert the RET Programmer CD Rom into the drive and run the Setup Application file.
2. Press the "OK" button to begin the installation program.
3. The program will be placed in the C:\Program Files\Programmer directory unless otherwise specified. Press the computer icon to continue the installation into the specified directory.
4. Press "Continue" on the next screen or change the Program group designation before proceeding.
5. If a "version conflict" message is displayed, press "Yes" to keep the existing file.
6. Press the "OK" button on the "RET Programmer Setup" display after the program is installed.
7. To run the program press the Windows start button and follow the path C:\programs\RET Programmer\RET Programmer.

8. On the initial setup press "View" on the top title bar and choose "options". Use the pull-down menu to select the COM port that the RET Programmer will be using. Press "OK" after the selection is made. **NOTE:** In order to activate the change in the COM port selection you must exit the RET Programmer software. To exit the software press the "Exit Programmer" button or the X on the top corner of the screen and reinitiate the RET Program. **NOTE:** All applications used on the selected COM port must be shut off. Consult the Task Manager by pressing the Ctrl+Alt+Delete keys simultaneously and shut off the appropriate applications.

General Operation:

To program or read an RET, connect the RET Programmer to the RET via the connector. Connect the RET Programmer 9-pin cable to the computer serial port and activate the RET Programmer software.

To run the program press the Windows start button and follow the path C:\programs\RET Programmer\RET Programmer. The RET Programmer has two main functions as indicated by the two tabs on the top of the screen.

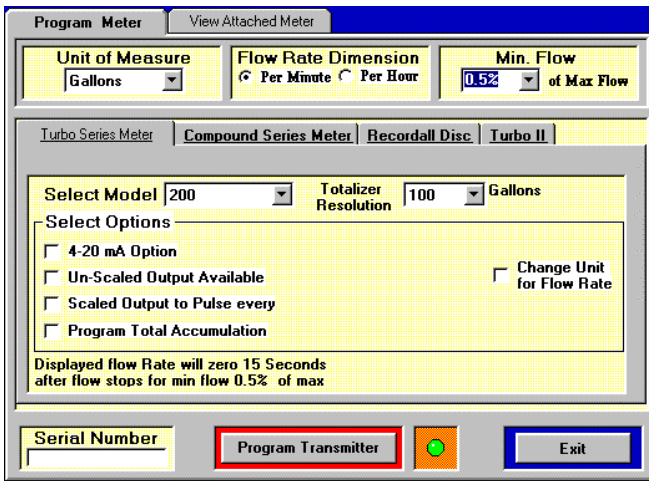

Program Meter: Used to program the RET for the desired meter with specific parameters.

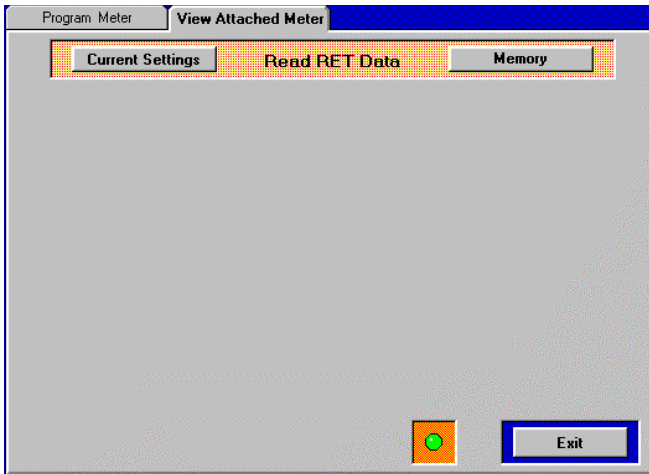

View Attached Meter: Allows the user to view the programmer parameters of an existing RET™.

The Program Meter tab contains a series of tabs, check boxes, pull-down screens, and data boxes to select the meter type, meter model, unit of measure, and other programmed parameters.

For each meter type and model there is a series of default parameters for that model associated with the unit of measure. These settings can be modified to customize the RET. The RET Programmer will insure that the chosen parameters are legitimate. If parameters are not valid, the RET Programmer will notify the user via an error message.

To change the Programmer function (Program Meter / View Attached Meter) or model type use the mouse to move the arrow to the desired tab and click the left mouse button.

To change a pull-down menu box use the mouse to move the arrow to the down-arrow of the appropriate box. Left click the mouse to activate the pull-down menu. Move the mouse to the desired option and left click the mouse.

To activate a check-box use the mouse to move the arrow to the desired box. Left click the mouse to select or de-select a box.

To change the non pull-down numeric boxes use the mouse to

move the pointer to the desired box. Click the left mouse button to place the cursor in the box. Use the backspace key to erase the existing number and use the keyboard to input a new number.

After the parameters are chosen, press the “Program Transmitter” button. During programming the green light next to the “Abort Transfer” button will turn red. If the programming is successful, the light will return to green. If the program is not successful, the appropriate error message will be displayed.

Note: If a warning or error message occurs after the “Program Transmitter” button has been activated the “Program Meter” screen will revert to the default settings.

Note: As the user changes between meter type, meter model, unit of measure, or change unit of flow rate, the default values of the meter will be reloaded. This means that if the scaled output and 20 mA set point are changed by the user, a change in the unit of measure will load the default value rather than convert the number in the box.

The “View Attached Meter” tab allows the choices of a “Current Settings” and “Memory” button. Using the mouse to left click the Current Settings button to read the latest (up to date) settings of the RET.

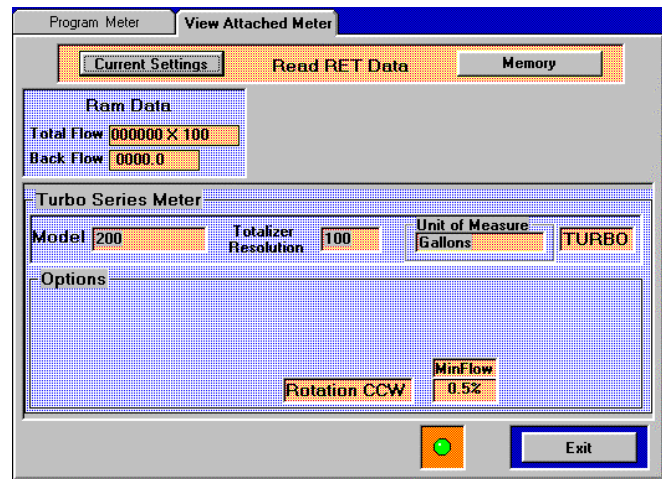

Using the Memory button allows the user to read the settings saved in the non-volatile memory. The Memory button is used to read the settings after the battery in the RET is fully consumed. The layout of the information for the “View Attached Meter” is similar to the “Program Meter” display.

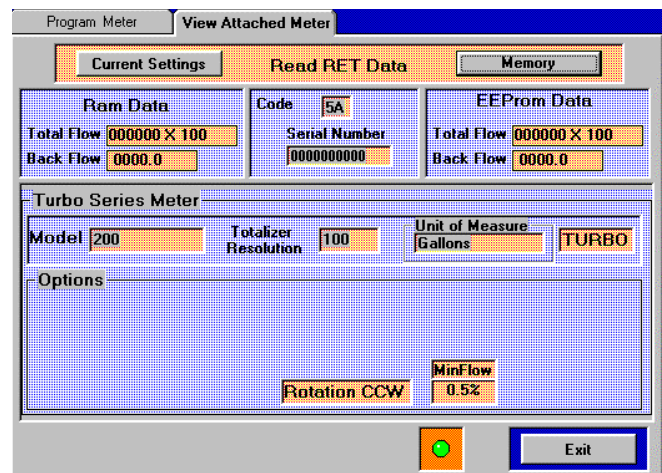

Note: When not being read or programmed the RET™ should be disconnected from the Programmer. This will keep the 9 volt battery in the RET Programmer from being drained.

Common Controls:

There are a number of button controls common to the “Program Meter” and “View Attached Meter” tabs.

Exit Programmer

This button will terminate the RET Programmer computer program.

Detailed Programming Options:

This section details the specific programming options. The parameters do not have to be chosen in any specific order. **However**, when a meter type, meter model, unit of measure or flow rate dimension are changed the other fields will be loaded with the default values.

Tabs allow the user to choose the type of meter that the RET will be used with. The options are; Turbo Series Meter, Compound Series Meter, Recordall® Disc, and Turbo II.

The “Select Model” pull down screen allows the user to choose between the models in each meter family. There are 35 meter model choices.

The “Unit of Measure” pull down box allows the choice of gallons, cubic feet, cubic meters, liters, or imperial gallons.

For each meter type, meter model, and unit of measure there are associated default parameters for the totalizer, scaled output, and 20 mA set point. Whenever a meter type, meter model, or unit of measure is changed, the default values are reloaded. The user has the option to customize the settings for their application.

Flow Rate Dimension

The “Flow Rate Dimension” is a check box that allows the flow rate to be shown as units per minute or units per hour. The units per hour is limited to 54,500. If a meter type and unit of measure is chosen where the flow rate is larger than 54,500 units per hour, the flow rate dimension will return to units per minute. The flow rate dimension is used for the rate displayed on the RET and the 20 mA set point.

Totalizer Resolution

The “Totalizer Resolution” pull down screen selects the resolution of the main display of the RET. On a typical mechanical register this would be referred to as the test circle. Since the RET does not have a sweep hand this field is referred to as Totalizer Resolution. The options are 0.01, 0.1, 1, 10, 100, 1000, and 10,000. There are lower limits depending on the meter model and unit of measure. If the Totalizer value selected is too low an error message will be displayed. The message will read, “Totalizer Resolution is too low for the meter model” and the value of this field is returned to the default value. As with any error message the RET is not programmed until the “Program Transmitter” button is pressed with valid parameters.

Change Unit for Flow Rate

The “Change Unit for Flow Rate” check box allows the operator to select a different unit for flow rate than is used for totalization. For example the user may want to totalize in cubic feet but display flow rate in gallons per minute. Checking this box activates a pull-down screen where the options are gallons, cubic feet, cubic meters, liters, and imperial gallons. **Note: When the totalization and flow rate are in different units the RET will not display a unit of measure icon.**

4-20 mA Option

The “4-20 mA Option” check box activates the 4 to 20 mA function of the RET. Activation of this box opens a numeric box that can be changed by the user. This number can be changed to a

number between 50% and 120% of the default flow rate. If a set point value is chosen that is not in the accepted range the user will be notified when the operator attempts to program the RET. The message will be, “The Set Point value entered was not within limits of 50% to 120%. Numeric Limits are ____ to ____” and the value of this field is returned to the default value. As with any error message the RET is not programmed until the “Program Transmitter” button is pressed with valid parameters.

Unscaled Output Available

The “Unscaled Output Available” check box activates the unscaled output of the RET.

Scaled Output to Pulse every

The “Scaled Output to Pulse every” check box activates the scaled output of the RET. Activation of this box opens a numeric box that can be changed by the user. There are lower limits depending on the meter model and unit of measure. If a Totalizer value is chosen that is too low the user will be notified when the operator attempts to program the RET. The message will be, “The scale Pulse value entered was less than the lower limit of ____” and the value of this field is set to the lowest limit. There may also be a message that reads, “Warning for MRT products Frequency is above 3 Hz.” If the RET is to be used with Badger® MRT products the input frequency must be < 3 Hz. Higher rates are allowed for use with other equipment. As with any error message the RET is not programmed until the “Program Transmitter” button is pressed with valid parameters.

Program Total Accumulation

The “Program Total Accumulation” check box activates a Pre-Load Totalization box where a 6 digit number can be loaded onto the display of the RET. If this box is not used the RET total is always loaded as 000000.

Min. Flow

The “Min. Flow” pull down screen allows the user to choose between various percentages (0.25%, 0.5%, 1.0%, 2.0%, 5.0%, 10.0%, 15%, 17.5%). The default for this value allows the rated ultra-low flow to be displayed. The percentage displayed is the percentage of the maximum flow. For example, if the maximum meter flow rate is 2000 GPM and the percentage specified is 2.0 % then the user would be able to see 40 GPM. This percentage will change the response rate of the RET at low flows. The percentage is shown at the lower left of the programming screen and states, “Displayed Flow Rate will zero XX seconds after flow stops for min flow X.X% of max.” As the percentage chosen increases the response time will become shorter. Flow rates below the minimum flow rate selected will be shown as zero flow with a milliamp output of 4 mA.

Serial Number

The “Serial Number” is a numeric box that allows the user to enter a 14 digit serial number for the RET. This serial number can be read back from the RET in the “View Attached Meter” operation. The serial number is not a mandatory field.

Alarm Cancellation

After an alarm condition has been observed on the display screen and resolved the alarm screen on the display can be deleted with the use of the RET Programmer. To do this select the “View Attached Meter” tab and simply click either the “Current Settings” or “Memory” button. This will clear the alarm screen from being displayed.

Other Functions

To change the COM port, press “View” on the top title bar and choose “options”. Use the pull-down menu to select the COM port that the RET Programmer will be using. Press “OK” after the selection is made. **NOTE:** In order to activate the change in the COM port selection you must exit the RET Programmer software. To exit the software press the “Exit Programmer” button or the X on the top corner of the screen and reinitiate the RET Program. **NOTE:** All applications used on the selected COM port must be shut off. Consult the Task Manager by pressing the

Ctrl+Alt+Delete keys simultaneously and shut off the appropriate applications.

The computer screens of the RET™ Programmer can be printed to provide a copy of the parameters. To print the screen press "View" on the top title bar and choose "Print".

Troubleshooting

If the RET Programmer is not operating:

1. Verify the connection between the RET and the RET Programmer.

2. Verify the 9 pin cable connection between the RET Programmer and the computer.
3. Verify the correct COM port is being used.
4. Verify that all applications used for the selected COM port are shut off. Consult the Task Manager by pressing the Ctrl+Alt+Delete keys simultaneously to shut off appropriate applications.
5. Check for bent pins on the RET Programmer connector.
6. Replace the 9 volt battery in the RET Programmer.

Troubleshooting

PROBLEM	POSSIBLE CAUSES	REMEDIES
Screen is blank	1. Battery is dead.	1. Replace unit.
Will not count	1. Broken or defective wiring. 2. Improperly connected. 3. Transmitter defective.	1. Check wiring. 2. Check connections. 3. Repair or replace transmitter.
Will not indicate rate of flow	1. Improperly connected. 2. Transmitter defective.	1. Check connections. 2. Repair or replace transmitter.
No Pulse or 4-20 mA Output	1. Defective output Transistor 2. Improper wiring	1. Replace unit 2. Check connections

For further assistance, call our Technical Support Staff at 1-800-876-3837.

Note: The power supply of the 4 to 20 signal must be isolated for the digital counter ground.

This chart lists all the settings or possible settings for the RET™ by meter model.
 The data in the default columns indicates the factory settings of the unit, unless otherwise specified by the customer.

RET™ FLOWRATE AND RESOLUTION CHART

Meter	Model	Meter ID	Units	Default Total (units)	Minimum Total (units)	Default Rate (units/min)	Default Scaled Output	Minimum Scaled Output	Default Rate @ 20 mA (units/min)	Unscaled Pulses (pulses/unit)
Disc	25	d25	gal	10	1	0.1	1	0.0418	25.0000	396.6808
Disc	25	d25	ft3	1	0.1	0.01	0.1	0.0057	3.3420	2967.3760
Disc	25	d25	m3	0.1	0.01	0.01	0.01	0.0002	0.0947	104712.4000
Disc	25	d25	IMP	10	1	0.1	1	0.0348	20.8183	476.2456
Disc	25	d25	liter	10	1	0.1	1	0.1579	94.6525	104.7124
Disc	35	d35	gal	10	1	0.1	1	0.0584	35.0000	253.3424
Disc	35	d35	ft3	1	0.1	0.01	0.1	0.0079	4.6788	1895.4000
Disc	35	d35	m3	0.1	0.01	0.01	0.01	0.0002	0.1325	66923.6000
Disc	35	d35	IMP	10	1	0.1	1	0.0487	29.1456	304.2928
Disc	35	d35	liter	10	1	0.1	1	0.221	132.5135	66.9236
Disc	40	d40	gal	10	1	0.1	1	0.0668	40.0000	179.5624
Disc	40	d40	ft3	1	0.1	0.01	0.1	0.009	5.3472	1343.5280
Disc	40	d40	m3	0.1	0.01	0.01	0.01	0.0003	0.1514	47477.5200
Disc	40	d40	IMP	10	1	0.1	1	0.05556	33.3092	215.7056
Disc	40	d40	liter	10	1	0.1	1	0.2525	151.4440	47.4775
Disc	70	d70	gal	10	1	0.1	1	0.1168	70.0000	93.4496
Disc	70	d70	ft3	1	0.1	0.01	0.1	0.0157	9.3576	699.2640
Disc	70	d70	m3	0.1	0.01	0.01	0.01	0.0004	0.2650	24716.2400
Disc	70	d70	IMP	10	1	0.1	1	0.0973	58.2911	112.2168
Disc	70	d70	liter	10	1	0.1	1	0.4417	265.0270	24.7162
Disc	120	d120	gal	100	1	1	10	0.2	120.0000	47.7343
Disc	120	d120	ft3	10	0.1	0.1	1	0.0267	16.0416	357.0128
Disc	120	d120	m3	1	0.01	0.01	0.1	0.0008	0.4543	12611.3440
Disc	120	d120	IMP	100	1	1	10	0.1666	99.9276	57.3693
Disc	120	d120	liter	100	10	1	10	0.7573	454.3320	12.6113
Disc	170	d170	gal	100	1	1	10	0.2834	170.0000	29.1302
Disc	170	d170	ft3	10	1	0.1	1	0.038	22.7256	217.9563
Disc	170	d170	m3	1	0.01	0.01	0.1	0.0012	0.6436	7694.7040
Disc	170	d170	IMP	100	1	1	10	0.236	141.5641	34.9846
Disc	170	d170	liter	100	10	1	10	1.073	643.6370	7.6947
Disc	180	d180	gal	100	1	1	10	0.3	180.0000	20.0689
Disc	180	d180	ft3	10	1	0.1	1	0.0402	24.0624	150.1246
Disc	180	d180	m3	1	0.01	0.01	0.1	0.0012	0.6815	5303.8168
Disc	180	d180	IMP	100	1	1	10	0.2499	149.8914	24.1002
Disc	180	d180	liter	100	10	1	10	1.136	681.4980	5.3038
TSM	160	Γ160	gal	100	10	1	10	0.6509	200.0000	3.0733
TSM	160	Γ160	ft3	10	1	0.1	1	0.0871	26.7360	22.9999
TSM	160	Γ160	m3	1	0.01	0.01	0.1	0.0026	0.7572	812.7840
TSM	160	Γ160	IMP	100	1	1	10	0.542	166.5460	3.6906
TSM	160	Γ160	liter	100	10	1	10	2.461	757.2200	0.8128
TSM	200	Γ200	gal	100	10	1	10	0.6509	310.0000	3.0733
TSM	200	Γ200	ft3	10	1	0.1	1	0.0871	41.4408	22.9999
TSM	200	Γ200	m3	1	0.01	0.01	0.1	0.0026	1.1737	812.7840
TSM	200	Γ200	IMP	100	10	1	10	0.542	258.1463	3.6906
TSM	200	Γ200	liter	100	10	1	10	2.461	1173.6910	0.8128
TSM	450	Γ450	gal	100	10	1	10	0.9168	550.0000	3.1964
TSM	450	Γ450	ft3	10	1	0.1	1	0.1226	73.5240	23.9417
TSM	450	Γ450	m3	1	0.1	0.01	0.1	0.0036	2.0824	844.0456
TSM	450	Γ450	IMP	100	10	1	10	0.7634	458.0015	3.8440
TSM	450	Γ450	liter	100	100	1	10	3.471	2082.3550	0.8440
TSM	1000	Γ1000	gal	100	10	1	10	2.084	1250.0000	3.3299
TSM	1000	Γ1000	ft3	10	1	0.1	1	0.2786	167.1000	24.9113
TSM	1000	Γ1000	m3	1	0.1	0.01	0.1	0.008	4.7326	879.2224
TSM	1000	Γ1000	IMP	100	10	1	10	1.735	1040.9125	3.9998
TSM	1000	Γ1000	liter	100	100	1	10	7.888	4732.6250	0.8792
TSM	2000	Γ2000	gal	1000	100	1	100	6.665	2500.0000	0.3001
TSM	2000	Γ2000	ft3	100	10	1	10	0.8936	334.2000	2.2385
TSM	2000	Γ2000	m3	10	0.1	0.1	1	0.0253	9.4653	79.2195
TSM	2000	Γ2000	IMP	1000	100	1	100	5.547	2081.8250	0.3606
TSM	2000	Γ2000	liter	1000	100	1	100	25.25	9465.2500	0.0792

RET™ FLOW RATE AND RESOLUTION CHART

Meter	Model	Meter ID	Units	Default Total (units)	Minimum Total (units)	Default Rate (units/min)	Default Scaled Output	Minimum Scaled Output	Default Rate @ 20 mA (units/min)	Unscaled Pulses/unit
TSM	3500	Γ3500	gal	1000	100	1	100	7.5	4500.0000	0.3029
TSM	3500	Γ3500	ft3	100	10	1	10	1.003	601.5600	2.2665
TSM	3500	Γ3500	m3	10	0.1	0.1	1	0.0285	17.0375	79.9972
TSM	3500	Γ3500	IMP	1000	100	1	100	6.246	3747.2850	0.3639
TSM	3500	Γ3500	liter	1000	100	1	100	28.4	17037.4500	0.0800
TSM	5500	Γ5500	gal	1000	100	1	100	11.67	7000.0000	0.3961
TSM	5500	Γ5500	ft3	100	10	1	10	1.56	935.7600	2.9627
TSM	5500	Γ5500	m3	10	1	0.1	1	0.0443	26.5027	104.6926
TSM	5500	Γ5500	IMP	1000	100	1	100	9.716	5829.1100	0.4757
TSM	5500	Γ5500	liter	1000	1000	1	100	44.18	26502.7000	0.1047
TSM	6200	Γ6200	gal	10000	100	1	1000	14.67	8800.0000	0.2574
TSM	6200	Γ6200	ft3	1000	10	1	100	1.961	1176.3840	1.9266
TSM	6200	Γ6200	m3	100	1	1	10	0.0556	33.3177	67.9822
TSM	6200	Γ6200	IMP	10000	100	1	1000	12.22	7328.0240	0.3092
TSM	6200	Γ6200	liter	10000	1000	1	1000	55.53	33317.6800	0.0680
TSM	6600	Γ6600	gal	10000	100	1	1000	64.33	13200.0000	0.0311
TSM	6600	Γ6600	ft3	1000	10	1	100	8.6	1764.5760	0.2326
TSM	6600	Γ6600	m3	100	1	1	10	0.2436	49.9765	8.2144
TSM	6600	Γ6600	IMP	10000	100	1	1000	53.57	10992.0360	0.0373
TSM	6600	Γ6600	liter	10000	1000	1	1000	243.5	49976.5200	0.0082
TSM	10000	Γ10000	gal	10000	1000	1	1000	110.9	19800.0000	0.0180
TSM	10000	Γ10000	ft3	1000	100	1	100	14.83	2646.8640	0.1349
TSM	10000	Γ10000	m3	100	1	1	10	0.42	74.9648	4.7656
TSM	10000	Γ10000	IMP	10000	100	1	1000	92.33	16488.0540	0.0217
TSM	10000	Γ10000	liter	10000	1000	1	1000	420	74964.7800	0.0048
CSM	2"H	C170H	gal	100	10	1	10	0.6509	200.0000	3.0733
CSM	2"L	C170L	gal	10	1	0.1	1	0.0418	25.0000	396.6808
CSM	2"H	C170H	ft3	10	1	0.1	1	0.0871	26.7360	22.9999
CSM	2"L	C170L	ft3	1	0.1	0.01	0.1	0.0057	3.3420	2967.3760
CSM	2"H	C170H	m3	1	0.01	0.01	0.1	0.0026	0.7572	812.7840
CSM	2"L	C170L	m3	0.1	0.01	0.01	0.01	0.0002	0.0947	104712.4000
CSM	2"H	C170H	IMP	100	10	1	10	0.542	166.5460	3.6906
CSM	2"L	C170L	IMP	10	1	0.1	1	0.0348	20.8183	476.2456
CSM	2"H	C170H	liter	100	10	1	10	2.461	757.2200	0.8128
CSM	2"L	C170L	liter	10	1	0.1	1	0.1579	94.6525	104.7124
CSM	3"H	C400H	gal	100	10	1	10	0.75	450.0000	3.1964
CSM	3"L	C400L	gal	10	1	0.1	1	0.0418	25.0000	396.6808
CSM	3"H	C400H	ft3	10	1	0.1	1	0.1003	60.2000	23.9417
CSM	3"L	C400L	ft3	1	0.1	0.01	0.1	0.0057	3.3420	2967.3760
CSM	3"H	C400H	m3	1	0.1	0.01	0.1	0.0029	1.7000	844.0456
CSM	3"L	C400L	m3	0.1	0.01	0.01	0.01	0.0002	0.0947	104712.4000
CSM	3"H	C400H	IMP	100	10	1	10	0.6246	375.0000	3.8440
CSM	3"L	C400L	IMP	10	1	0.1	1	0.0348	20.8183	476.2456
CSM	3"H	C400H	liter	100	100	1	10	2.84	1700.0000	0.8440
CSM	3"L	C400L	liter	10	1	0.1	1	0.1579	94.6525	104.7124
CSM	4"H	C800H	gal	100	10	1	10	1.667	1000.0000	3.3299
CSM	4"L	C800L	gal	10	1	0.1	1	0.0584	35.0000	253.3424
CSM	4"H	C800H	ft3	10	10	0.1	1	0.2228	134.0000	24.9113
CSM	4"L	C800L	ft3	1	0.1	0.01	0.1	0.0079	4.6788	1895.4000
CSM	4"H	C800H	m3	1	0.1	0.01	0.1	0.0064	3.7900	879.2224
CSM	4"L	C800L	m3	0.1	0.01	0.01	0.01	0.0002	0.1325	66923.6000
CSM	4"H	C800H	IMP	100	10	1	10	1.388	833.0000	3.9998
CSM	4"L	C800L	IMP	10	1	0.1	1	0.0487	29.1456	304.2928
CSM	4"H	C800H	liter	100	100	1	10	6.31	3790.0000	0.8792
CSM	4"L	C800L	liter	10	10	0.1	1	0.221	132.5135	66.9236
CSM	6"H	C1500H	gal	1000	100	1	100	6.664	2000.0000	0.3001
CSM	6"L	C1500L	gal	10	1	0.1	1	0.0584	35.0000	253.3424
CSM	6"H	C1500H	ft3	100	10	1	10	0.8935	267.0000	2.2385
CSM	6"L	C1500L	ft3	1	0.1	0.01	0.1	0.0079	4.6788	1895.4000
CSM	6"H	C1500H	m3	10	0.1	0.1	1	0.0253	7.5700	79.2195
CSM	6"L	C1500L	m3	0.1	0.01	0.01	0.01	0.0002	0.1325	66923.6000
CSM	6"H	C1500H	IMP	1000	100	1	100	5.547	1670.0000	0.3606
CSM	6"L	C1500L	IMP	10	1	0.1	1	0.0487	29.1456	304.2928
CSM	6"H	C1500H	liter	1000	100	1	100	25.25	7570.0000	0.0792
CSM	6"L	C1500L	liter	10	10	0.1	1	0.221	132.5135	66.9236

RET™ FLOW RATE AND RESOLUTION CHART

Meter	Model	Meter ID	Units	Default Total (units)	Minimum Total (units)	Default Rate (units/min)	Default Scaled Output	Minimum Scaled Output	Default Rate @ 20 mA (units/min)	Unscaled Pulses (pulses/unit)
turbo II	2	ΓII-2	gal	100	10	1	10	0.677	310.0000	2.9545
turbo II	2	ΓII-2	ft3	10	1	0.1	1	0.0906	41.4408	22.0903
turbo II	2	ΓII-2	m3	1	0.01	0.01	0.1	0.0027	1.1737	780.5132
turbo II	2	ΓII-2	IMP	100	10	1	10	0.5637	258.1463	3.5483
turbo II	2	ΓII-2	liter	100	10	1	10	2.563	1173.6910	0.7806
turbo II	3	ΓII-3	gal	100	10	1	10	1.1	660.0000	2.9230
turbo II	3	ΓII-3	ft3	10	1	0.1	1	0.1471	88.2288	21.8616
turbo II	3	ΓII-3	m3	1	0.1	0.01	0.1	0.0043	2.4988	772.3902
turbo II	3	ΓII-3	IMP	100	10	1	10	0.9161	549.6018	3.5105
turbo II	3	ΓII-3	liter	100	10	1	10	3.156	2498.8260	0.7722
turbo II	4	ΓII-4	gal	100	10	1	10	2.084	1250.0000	1.9380
turbo II	4	ΓII-4	ft3	10	1	0.1	1	0.2786	167.1000	14.4998
turbo II	4	ΓII-4	m3	1	0.1	0.01	0.1	0.008	4.7326	511.9155
turbo II	4	ΓII-4	IMP	100	10	1	10	1.735	1040.9125	2.3274
turbo II	4	ΓII-4	liter	100	100	1	10	7.888	4732.6250	0.5119
turbo II	6	ΓII-6	gal	1000	100	1	100	5.98	2650.0000	0.3345
turbo II	6	ΓII-6	ft3	100	10	1	10	0.7995	354.2520	2.5018
turbo II	6	ΓII-6	m3	10	0.1	0.1	1	0.0228	10.0332	88.2662
turbo II	6	ΓII-6	IMP	1000	100	1	100	4.98	2206.7345	0.4016
turbo II	6	ΓII-6	liter	1000	100	1	100	22.66	10033.1650	0.0883
turbo II	8	ΓII-8	gal	1000	100	1	100	9.086	3100.0000	0.2201
turbo II	8	ΓII-8	ft3	100	10	1	10	1.214	414.4080	1.6478
turbo II	8	ΓII-8	m3	10	0.1	0.1	1	0.0345	11.7369	58.1579
turbo II	8	ΓII-8	IMP	1000	100	1	100	7.569	2581.4630	0.2643
turbo II	8	ΓII-8	liter	1000	100	1	100	34.39	11736.9100	0.0582
turbo II	10	ΓII-10	gal	1000	100	1	100	29.59	5280.0000	0.0676
turbo II	10	ΓII-10	ft3	100	10	1	10	3.956	705.8304	0.5056
turbo II	10	ΓII-10	m3	10	1	0.1	1	0.1121	19.9906	17.8560
turbo II	10	ΓII-10	IMP	1000	100	1	100	24.64	4396.8144	0.0812
turbo II	10	ΓII-10	liter	1000	100	1	100	100	19990.6080	0.0179
turbo II	12	ΓII-12	gal	10000	100	1	1000	37.38	6600.0000	0.0535
turbo II	12	ΓII-12	ft3	1000	10	1	100	4.997	882.2880	0.4003
turbo II	12	ΓII-12	m3	100	1	1	10	0.1416	24.9883	14.1320
turbo II	12	ΓII-12	IMP	10000	100	1	1000	31.12	5496.0180	0.0643
turbo II	12	ΓII-12	liter	10000	1000	1	1000	141.6	24988.2600	0.0141
turbo II	16	ΓII-16	gal	10000	100	1	1000	64.33	13200.0000	0.0311
turbo II	16	ΓII-16	ft3	1000	10	1	100	8.598	1764.5760	0.2326
turbo II	16	ΓII-16	m3	100	1	1	10	0.2436	49.9765	8.2144
turbo II	16	ΓII-16	IMP	10000	100	1	1000	53.57	10992.0360	0.0373
turbo II	16	ΓII-16	liter	10000	1000	1	1000	243.5	49976.5200	0.0082
turbo II	20	ΓII-20	gal	10000	1000	1	1000	110.9	19800.0000	0.0180
turbo II	20	ΓII-20	ft3	1000	100	1	100	14.83	2646.8640	0.1349
turbo II	20	ΓII-20	m3	100	1	1	10	0.4198	74.9648	4.7656
turbo II	20	ΓII-20	IMP	10000	100	1	1000	92.33	16488.0540	0.0217
turbo II	20	ΓII-20	liter	10000	1000	1	1000	419.7	74964.7800	0.0048

THIS DEVICE COMPLIES WITH PART 15 OF FCC RULES. OPERATION OF THIS DEVICE IS SUBJECT TO THE FOLLOWING TWO CONDITIONS: (1) THIS DEVICE MAY NOT CAUSE HARMFUL INTERFERENCE. (2) THIS DEVICE MUST ACCEPT ANY INTERFERENCE RECEIVED, INCLUDING INTERFERENCE THAT MAY CAUSE UNDESIRE OPERATION.

U.S. PAT No. 5,734,103 AND OTHERS APPLIED FOR.

Badger® and Recordall® are registered trademarks of Badger Meter, Inc.
RET™ is a trademark of Badger Meter, Inc.



Please see our website at
www.badgermeter.com
for specific contacts.

Due to continuous research, product improvements and enhancements, Badger Meter reserves the right to change product or system specifications without notice, except to the extent an outstanding bid obligation exists.



BadgerMeter, Inc.

P.O. Box 245036, Milwaukee, WI 53224-9536
(800) 876-3837 / Fax: (888) 371-5982

www.badgermeter.com