

Type 1711

1/2", 3/4" and 1" Heavy Duty Union Bonnet Valve Assembly RESEARCH CONTROL® Valves

Technical Brief

DESCRIPTION

The Type 1711 globe control valve is available in 1/2", 3/4", and 1" sizes. It is designed for modulating flow or pressure control in industrial and research applications at temperatures of 850°F or less (400°F maximum for TFE chevron packing and standard bonnet). The unit features an oversized stem and extra heavy guided innervalve for added strength and longevity. The stem packing is designed for tight sealing, long life and quick, easy maintenance. The union bonnet with a graphite gasket provides excellent sealing without having bonnet threads in contact with the process fluid. The multi-spring, 35-square-inch, diaphragm actuator can be either ATO or ATC action. Maximum corrosion protection on all non-stainless actuator components is standard. The spring preload is fully adjustable.

APPLICATIONS

This RESEARCH® valve is suited for many applications in chemical, petroleum and other industries requiring a rugged, compact, heavy duty valve.

MATERIALS OF CONSTRUCTION

Body – Bonnet:	316 SST
Body Gasket:	Grafoil® Gr GTA
Innervalve:	
Standard	316 SST or Stellite® inlaid seat and plug
Optional	Titanium nitride coated
Packing:	
Standard	TFE chevron rings
Optional	Grafoil, others; consult factory
Actuator:	
Pressure Cases, Yoke	Polyurethane enamel coated steel
Springs	17-7 PH SST
Diaphragm	Buna
Minor Fasteners	300 Series stainless steel

ACTUATOR

Standard	Air-to-open, fail close Air-to-close, fail open
Optional	Side mounted positioner
Standard Signals	3-15#, 3-27#, 6-30#
Optional Signals	3-9#, 9-15# with positioner
Accessories	Filter regulator, gauges, I/P converter, limit switches, solenoids



STANDARD FEATURES

- Interchangeable innervalves
- Choice of linear or equal percent innervalves
- Stellite inlaid innervalves
- TFE chevron packing
- ANSI Class IV shutoff
- High Pressure/temperature rating
- Encapsulated graphite body gasket
- Polyurethane enamel coated pressure cases inside and out
- Adjustable spring preload and up travel stop
- Dual IEC 534 (NAMUR) accessory mounts

OPTIONAL FEATURES

- Graphite and other special packings
- Extended and other special bonnets
- Socket-weld or butt-weld ends
- Flanges

RESEARCH CONTROL® is a registered trademark of BadgerMeter, Inc.

Grafoil® is a registered trademark of Graftech, Inc.

Stellite® is a registered trademark of Haynes International, Inc.



BadgerMeter, Inc.

941326

6-04

Description of Items

- | | |
|-------------------|--|
| 1. Body | 5. Gasket |
| 2. Bonnet | 6. Union nut |
| 3. Innervalue set | 7. Packing kit |
| 3a. Innervalue | 8. Gland |
| 3b. Seat | 9. Actuator (shown ATO; refer to CD-951593 & CD-951594 for details). See Note 1. |
| 4. Locknut | |

Note 1:

Without positioner 4 springs must be used.
With positioner 3,4, or 6 springs may be used.

Dimensions (inches)					
Ps	A	B	C	D	E
1/2"	2.75	1.00	2.89	13.37	9.81
3/4"	3.38	1.19	3.08	13.56	9.81
1"	4.00	1.50	3.72	14.20	9.81
Removal clearance: 1.75" (45 mm)					
Valve Stem travel: 0.563" (14.3 mm)					

Pressure versus Temperature							
Temp (°F)	1/2" (psig)	3/4" (psig)	1" (psig)	Temp (°C)	1/2" (psig)	3/4" (bar)	1" (bar)
75	7500	5000	5000	24	517	345	345
100	7475	4980	4980	38	515	343	343
200	6625	4415	4415	93	457	304	304
300	6000	4000	4000	149	414	276	276
400	5375	3580	3580	204	371	247	247
500	5075	3380	3380	260	350	233	233
600	4825	3215	3215	316	333	222	222
700	4600	3065	3065	371	317	211	211
800	4525	3015	3015	427	312	208	208
850	4560	2965	2965	454	314	204	204

Consult factory for high temperatures.

Innervalue Chart								
Valve Size	Trim	Cv	Maximum Rangeability		Port Dia.	Orifice Area (Sq. In)	Maximum Shut-off*	
			Linear	=%			1/2" (psig)	3/4", 1" (psig)
1"	6.0	6.0	50:1	60:1	0.625"	0.307		1,700
1"	5.0	5.0	50:1	60:1	0.625"	0.307		1,700
1"	4.5	4.5	50:1	60:1	0.500"	0.197		2,650
3/4"-1"	4.0	4.0	50:1	60:1	0.500"	0.197		2,650
3/4"-1"	3.5	3.5	50:1	60:1	0.500"	0.197		2,650
1/2"-1"	A	2.5	50:1	50:1	0.375"	0.1105	4,700	4,700
1/2"-1"	B	2.0	40:1	50:1	0.375"	0.1105	4,700	4,700
1/2"-1"	C	1.25	40:1	50:1	0.281"	0.0621	7,500*	5,000*
1/2"-1"	D	0.8	40:1	50:1	0.250"	0.0491	7,500*	5,000*
1/2"-1"	E	0.5	40:1	50:1	0.250"	0.0491	7,500*	5,000*
1/2"-1"	F	0.32	30:1	40:1	0.156"	0.0191	7,500*	5,000*
1/2"-1"	G	0.2	30:1	40:1	0.156"	0.0191	7,500*	5,000*
1/2"-1"	H	0.13	30:1	40:1	0.156"	0.0191	7,500*	5,000*
1/2"-1"	I	0.08	30:1	40:1	0.156"	0.0191	7,500*	5,000*
1/2"-1"	J	0.05	30:1	40:1	0.156"	0.0191	7,500*	5,000*

*Maximum allowable shut-off is determined by the maximum force that can be preloaded using six springs loaded to 525 lbs force. Although the unit will close the valve, this is no guarantee that the metal will not erode. Life of the innervalue is related to the fluid, temperature, nature of the media and the pressure.

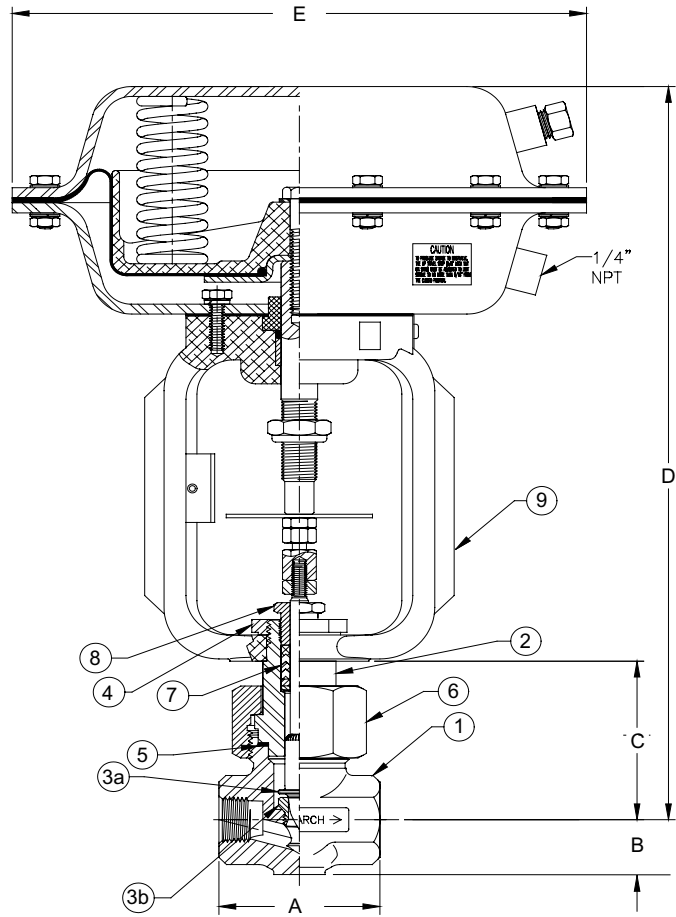

All rights reserved. All data subject to change without notice.

Due to continuous research, product improvements and enhancements, Badger Meter reserves the right to change product or system specifications without notice, except to the extent an outstanding bid obligation exists.

Please see our website at
www.badgermeter.com
for specific contacts.



BadgerMeter, Inc.

P.O. Box 581390, Tulsa, Oklahoma 74158
(918) 836-8411 / Fax: (918) 832-9962

www.badgermeter.com