

GENERAL

The models FT-1E, PFT-2E and PFT-3E are electronic transmitters which have unscaled pulse outputs for use with Badger Meter's line of industrial turbo, disc, and oscillating piston flow meters. (See transmitter selection chart below.)

These transmitters incorporate magnetoresistive sensors with open collector NPN transistor outputs. They will interface with Badger's PC100 controller as well as other devices that have similar operating characteristics.

This style of electronic transmitter offers improved performance over mechanical transmitters by elimination of mechanical coupling to the meter in addition to providing the higher reliability and resolution of solid-state components.

OPERATION

The interaction between the unscaled transmitter and the 4-pole meter magnet generates four pulses for each revolution of the magnet, which will rotate a precise number of times for a given quantity of fluid passing through the meter.

Table 2 lists the transmitter output, expressed in pulses per ounce and pulses per gallon, for the various types and sizes of meters that you could use with these transmitters.

These output pulses are normally fed to a process controller that can multiply these pulses by a number between 0.0001 and 0.9999 (the scale factor), which will express the output pulses as standard engineering units of measure such as 1, 10 or 100 pulses per gallon, liter or quart.

Badger's PC100 electronic batch controller and ER-8 and ER-9 registers have the ability to perform this scaling function.

Meter Type	FT-1E	PFT-2E	PFT-3E
Disc		X	
Turbine			X
OP	X		

Table 1. Transmitter Selection Chart



PFT-2E Transmitter

FEATURES

- Long-life, all solid-state components
- Rugged, high impact resistant enclosure for PFT-2E and PFT-3E
- Stainless steel cover (FT-1E only)
- High temperature rating: 250° F.
- Corrosion resistant components
- Watertight - NEMA 4X housing (PFT-2E and PFT-3E)
- Sealed pickup assembly (all models)



SPECIFICATIONS

HOUSING	
Material:	High Impact, Reinforced Nylon (PFT Series)
Mounting:	Bayonet Type with Set Screw, 360° Orientation
Connections:	Two 1/2" NPT Threaded Conduit Ports
Protection:	NEMA 4X (Watertight and Corrosion Proof)

OPERATION	
Type:	Solid-State
Pulse Generation:	Open Collector NPN Transistor
Operating Temperature:	-40° to 302° F* (-40° to 150° C)*
*Limited by flow meter specifications	

ELECTRICAL	
Supply Voltage:	6.0 to 24 VDC
Supply Current:	13.5 mA Maximum
Output Type:	Current Sinking (NPN)
Output Current:	20 mA Maximum

MAGNETIC	
Magnetics Type:	Omnipolar

GAUSS CHAR.	
Typical Operate:	15
Typical Release:	11
Typical Differential:	4

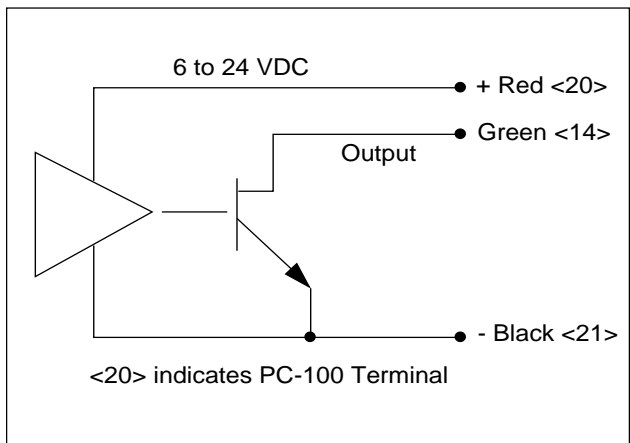

Magnetoresistive Sensor

SCALE FACTOR CALCULATION

Scale Factor =
$$\frac{\text{Pulses per gallon wanted}}{\text{Transmitter output in pulses per gallon}}$$

See the chart below for the average number of output pulses per gallon for your particular meter. For more precise calculations, use the information on the transmitter data plate when figuring scale factors.

Example:

Compute the scale factor for a 3" turbo meter. (You want to measure the flow to the nearest 0.1 gallon.)

Scale Factor = 10/24.80 = **0.4032**

Enter 0.4032 in the scaling function of the controller to read the meter flow to the nearest 0.1 of a gallon.

Meter	Size (Inch)	Pulse/Oz.	Pulse/Gal.
RCDL 25	5/8	1.550	198.40
RCDL 35	3/4	1.550	126.67
RCDL 40	1	0.702	89.80
RCDL 70	1	0.366	46.80
RCDL 120	1 1/2	0.186	23.80
RCDL 170	2	0.114	14.56
TURBO	2	0.271	34.72
TURBO	3	0.194	24.80
TURBO	4	0.040	5.12
TURBO	6	0.017	2.16
OP	1/2	1.742	222.96
OP	1	0.599	76.64
OP	2	0.161	20.56

Table 2.



Please see our website at www.badgermeter.com for specific regions and contacts.

Due to continuous research, product improvements and enhancements, Badger Meter reserves the right to change product or system specifications without notice, except to the extent an outstanding bid obligation exists.



BadgerMeter, Inc.

P.O. Box 245036, Milwaukee, WI 53224-9536
 Telephone: (414) 355-0400 / (877) 243-1010
 Fax: (414) 355-7499 / (866) 613-9305
www.badgermeter.com