

DESCRIPTION

Badger Meter offers the Badger 6" Compound Series meter in Cast Bronze and a Low Lead Alloy. The Cast Bronze (Trade Designation: Compound Series B81-NS) and the Low Lead Alloy (Trade Designation: Compound Series LL-NS) versions comply with NSF/ANSI Standard 61, Annex G and carry the NSF-61 Mark on the product.

APPLICATIONS: For use in measurement of potable cold water in commercial and industrial services where flow is in one direction only.

OPERATION: At low flow rates, the water is diverted up through a bypass to the disc chamber. Leaving the chamber's outlet port, water flows beyond the turbo and main valve. As the flow rate increases, a pressure differential is created which opens the main valve. The water then flows straight through the turbine chamber in addition to a portion still flowing through the disc chamber before exiting the meter. Rotor and disc movement are transmitted by magnetic drive couplings to individual register odometers.

OPERATING PERFORMANCE: With its' patented design, the Badger Recordall Compound meter meets or exceeds registration accuracy for low flow rate, normal operating flow rates, maximum continuous operation flow rate, and changeover flow rate as specifically stated in AWWA Standard C702.

CONSTRUCTION: Badger Recordall Compound meter construction which complies with ANSI and AWWA C702 standards, consists of three basic components: meter housing, interchangeable measuring elements and single, sealed direct reading registers. The measuring element consist of the disc measuring chamber, turbo head assembly and high flow valve assembly.

To simplify maintenance, the registers and measuring elements can be removed without removing the meter housing from the installation.

MAGNETIC DRIVE: Direct magnetic drive, through the use of high-strength magnets, provides positive, reliable and dependable register coupling for straight-reading or remote reading options.

SEALED REGISTERS: The standard registers consists of a straight-reading odometer-type totalization display, 360° test circle with center sweep hand and flow finder to detect leaks. Register gearing consists of self-lubricating thermoplastic gears to minimize friction and provide long life. Permanently sealed; dirt, moisture, tampering and lens fogging problems are eliminated. Multi-position register simplifies meter installation and reading. Automatic meter reading and close proximity systems are available for all Compound Series meters. (See back of sheet for additional information.) All reading options are removable from the meter without disrupting water service.

METER READING TECHNOLOGIES: The Badger ORION®, GALAXY® and Itron® ERT® meter reading systems are available for all Recordall Compound Series meters. An optional summator can be provided as an integral part of the register assembly. Refer to the back page for additional information.

TAMPER-PROOF FEATURES: Tamper resistant register provides protection from unauthorized personnel.

STRAINER: A separate strainer is recommended to protect the measuring element but is not a requirement. See Technical Brief PS-T-1 for strainer dimensions.

MAINTENANCE: Badger Recordall Compound meters are designed and manufactured to provide long-term service with minimal maintenance.

When maintenance is required, it can be performed easily either at the meter installation or at any other convenient location. As an alternative to repair by the utility, Badger offers various maintenance and meter component exchange programs to fit the needs of the utility.

CONNECTIONS: Companion flanges for installation of meters on various pipe types and sizes are available in cast iron or bronze as an option.

STANDARD: 3/4" drain plug.

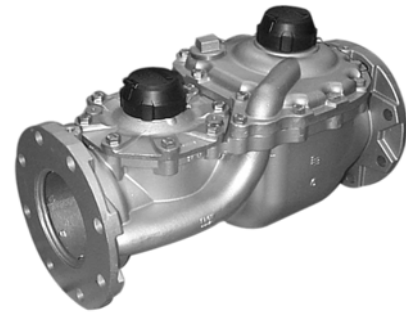

SPECIFICATIONS

Typical Operating Range (100% ± 1.5%)	3/4-2000 GPM (0.17 to 454.4 m³/h)
Low Flow Registration	3/8 GPM (0.09 m³/h)
Maximum Continuous Flow	1500 GPM (340.5 m³/h)
Pressure Loss at Maximum Continuous Flow	9.3 PSI at 1500 GPM (0.64 bar at 340.5 m³/h)
Pressure Loss at Crossover	5 PSI (0.35 bar)
Minimum Crossover Accuracy	95%
Maximum Operating Pressure	150 PSI (10 bar)
Maximum Operating Temperature	120°F (49°C)
Meter Flanges	6" Round Flanges, Class 150
Registers	Straight reading, permanently sealed magnetic drive standard. Automatic Meter Reading and Close Proximity units optional.
High Flow Registration	1,000,000,000 Gallons 1,000 gallons/sweep hand revolution. 100,000,000 Cubic Feet 100 cubic ft./sweep hand revolution. 1,000,000 m³ 1 m³/sweep hand revolution.
Low Flow Registration	10,000,000 Gallons 10 gallons/sweep hand revolution. 1,000,000 Cubic Feet 1 cubic ft./sweep hand revolution. 100,000 m³/sweep hand revolution. .1 m³/sweep hand revolution.

MATERIALS

Housing and Cover	Cast Bronze (B81), Low Lead Alloy
Turbo Cast Head	Cast Bronze (B81), Low Lead Alloy
Nose Cone and Straightening Vanes	Thermoplastic
Rotor	Thermoplastic
Rotor Radial Bearings	Lubricated Thermoplastic
Rotor Thrust Bearing	Sapphire Jewels
Rotor Bearing Pivots	Passivated 316 Stainless Steel
Calibration Mechanism	Stainless Steel And Thermoplastic
Measuring Chamber and Disc	Thermoplastic
High Flow Valve	Thermoplastic / Stainless Steel
Magnets	Ceramic
Register Lens	Glass
Register Housing and Cover	Thermoplastic or Bronze
Trim	Stainless Steel

PRESSURE LOSS CHART

Rate of Flow, in Gallons per Minute

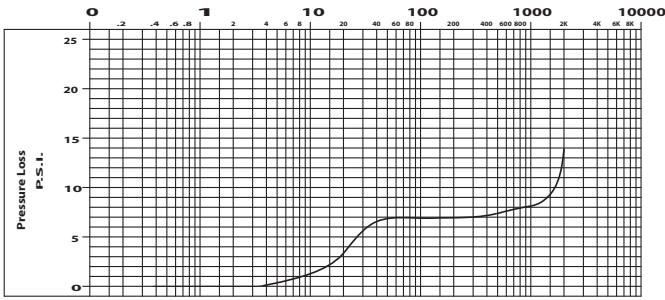

ACCURACY CHART

Rate of Flow, in Gallons per Minute

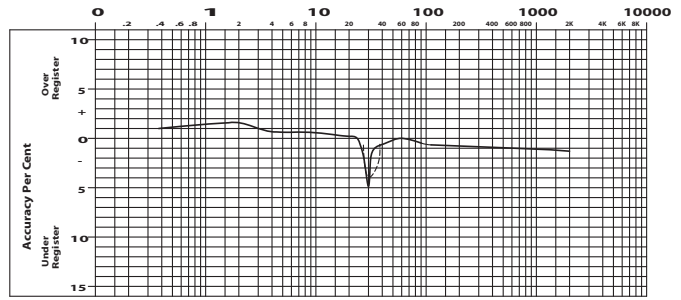

Meter & Pipe Size	DIMENSIONS								
	Length A	Width B	Height C	Flange D	Bolt Circle E	Centerline to F Base	No. Bolts	Net Weight	Shipping Weight
6" (DN 150)	24" (610mm)	12-3/8" (314mm)	8-7/8" (225mm)	1" (25mm)	9-1/2" (241mm)	5-3/8" (137mm)	8	152 lb. (68.7 kg)	200 lb. (90.4 kg)

PROPER INSTALLATION: The following installation guidelines will insure optimum field performance and reliability when installing a Badger® Compound Series meter.

1. A Strainer IS REQUIRED to insure optimum flow conditioning and protection for the Compound Series meter measuring element.
2. Compound meters, with a strainer, REQUIRE a minimum of five (5) pipe diameters of straight pipe upstream of the meter.
3. ONLY full-open gate valves should be used immediately upstream of the meter. Butterfly valves MUST be five (5) pipe diameters or more upstream of the meter. Full-open gate or butterfly valves can be used downstream.
4. DO NOT install pressure reducing devices or check valves upstream of the meter.
5. Unweighted check valves MUST be located at least three (3) pipe diameters downstream of the meter.
6. Pressure reducing devices and externally weighted check valves MUST be located at least five (5) pipe diameters downstream of the meter.

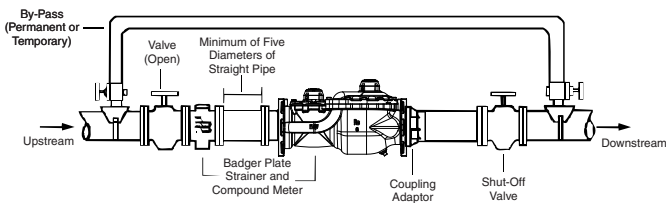
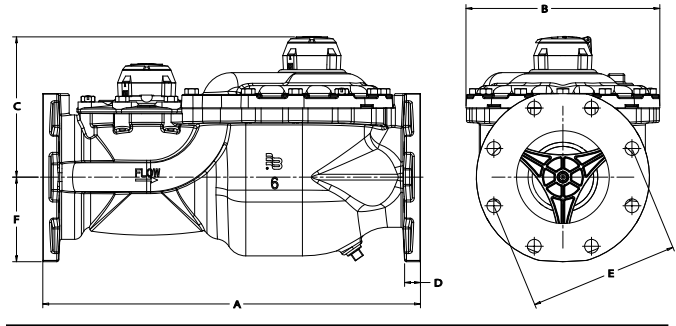

LOW FLOW

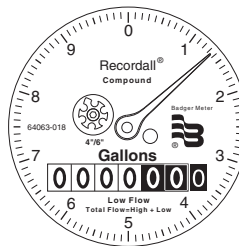

HIGH FLOW

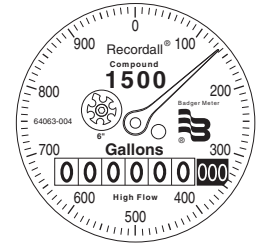

Badger®, GALAXY®, ORION® and Recordall® are registered trademarks of Badger Meter, Inc. Itron® and ERT® are registered trademarks of Itron, Inc.

Due to continuous research, product improvements and enhancements, Badger Meter reserves the right to change product or system specifications without notice, except to the extent an outstanding contractual obligation exists.



Please see our website at www.badgermeter.com for specific contacts.



BadgerMeter, Inc.

P.O. Box 245036, Milwaukee, WI 53224-9536
 (800) 876-3837 / Fax: (888) 371-5982
www.badgermeter.com