



SCOPE OF THIS MANUAL

This manual contains information concerning the installation, operation and maintenance of Badger's Magnetoflow® 7500S Sanitary Mag Flowmeters. To ensure proper performance of the meters covered, the instructions given in this manual should be thoroughly understood. Retain the manual in a readily accessible location for future reference.

DESCRIPTION AND OPERATION

Badger's 7500S Mag meters are intended for use in fluid metering applications for process batching where approved sanitary equipment is required.

The 7500S Mag meter is a stainless steel flow tube with an internal isolating lining. Two electromagnetic coils are located outside the flow tube, diametrically opposed to each other and protected by a stainless steel housing. Two electrodes, inserted into the flow tube, are positioned "flush" with the internal diameter of the tube and perpendicular to the coils. The coils are energized by a pulsed DC voltage provided by the electronic converter, and a magnetic field is generated across the flow tube section. According to Faraday's law, when conductive liquid flows through this magnetic field of the meter, a voltage is generated in the liquid. This voltage is directly proportional to the liquid flow velocity, and therefore to the actual volumetric flow rate of

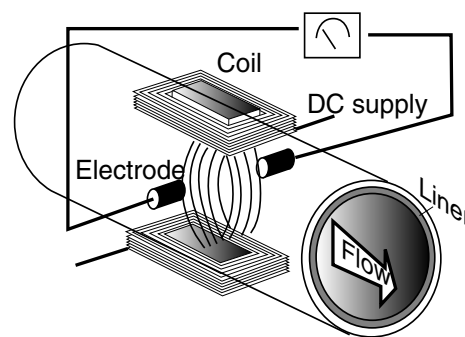

the liquid. The electronic converter measures this voltage, processes the signal, and provides two digital pulse outputs, scalable to the desired volumetric value. These digital pulse outputs can be connected to a batch controller, a totalizer display unit for monitoring purposes, or to both devices simultaneously. Magnetoflow® 7500S operation is not affected by suspended solids in the liquid. Variations of liquid temperature, viscosity or density have no influence in its principle of operation. A set of convenient, field proven pulse scaler rotary switches are provided for easy and straight-forward batch accuracy compensation.

UNPACKING AND INSPECTION

To avoid damage in transit, Badger meters are shipped to the customer in a special shipping container. Upon receipt of the meter, perform the following unpacking and inspection procedures. If damage to the shipping container is evident, be present when the meter is unpacked.

A. Carefully open the shipping container following any instructions that may be marked on the container. Remove all cushioning material surrounding the meter and carefully lift meter from container. Retain the container and all packing material for possible use in reshipment or storage.

B. Visually inspect the meter for any physical damage such as scratches, loose or broken parts, or any other sign of damage that may have occurred during shipment.

NOTE: If damage is found, request an inspection by the carrier's agent within 48 hours of delivery. Then file a claim with the carrier. A claim for equipment damaged in transit is the responsibility of the customer.

STORAGE

If the meter is not to be installed right away, store it in its original container in a dry, sheltered location. Storage temperature: -4 to 158°F (-20 to +70°C)

METER INSTALLATION

METER ORIENTATION

Magnetoflow Mag Meters can operate accurately in any pipe line orientation.

However, the most recommended installation position is vertical piping, with the the liquid flowing upward.

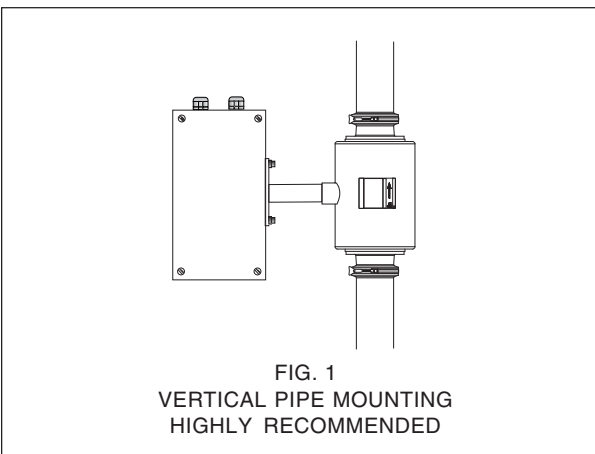

This installation practice ensures two objectives:

- The pipe remains completely full of liquid, even at low flow, low pressure applications with a discharge to the atmosphere.
- Solid build-ups or sediments that could be part of the process fluid will not deposit or accumulate on the liner and/or electrodes.

The model 7500S meter is designed to measure flow in one direction only. **Carefully observe the "forward flow" label attached to the meter body and install the meter accordingly.**

If horizontal piping orientation is required, the detector should be mounted in a position at which the electrodes axis will remain in an horizontal plane (3 and 9 o'clock position; see figure below).

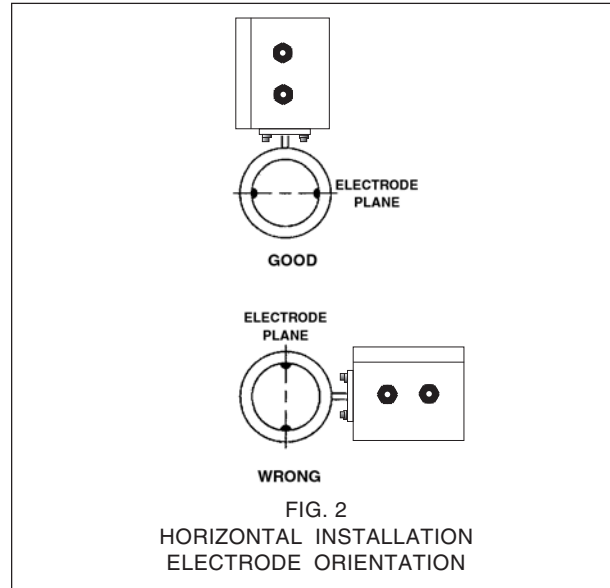

PIPING CONFIGURATION

Appropriate piping arrangements should be provided to ensure the meter is not exposed to extreme pipe vibrations. The piping arrangements should include appropriate pipe supports.

For optimum accuracy performance, it is required to provide sufficient inlet and outlet straight pipe runs. An equivalent of 3 diameters of straight pipe is required on the inlet side of the meter, and 2 diameters on the outlet side, measured from the center of the meter body.

Avoid installing the detector close to flow disturbance generating valves and fittings.

Do not install the detector in the outlet side of Piston or Diaphragm type pumps. Avoid all pipe locations where the flow is pulsating. Avoid installing the detector in the suction side of any pumps; possible creation of vacuum can affect meter performance or cause damage to the PTFE liner.

TEMPERATURE

Note: Environmental temperature of installation is not to exceed maximum specification of 122°F (50°) for the meter.

PIPING CONFIGURATION

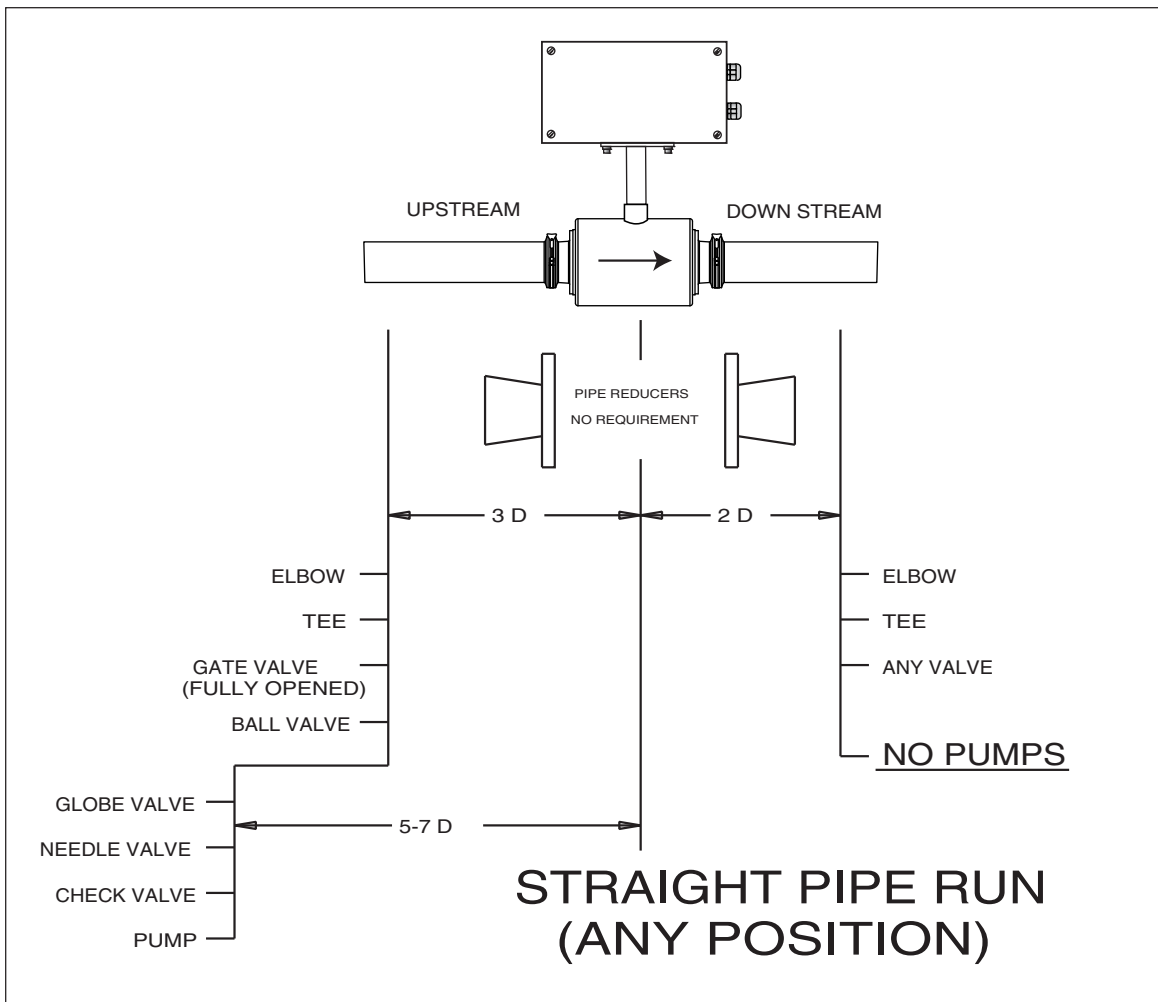

PARTIALLY FULL PIPE SITUATIONS

Magnetoflow® meters are designed to operate in closed, full pipes.

It is relatively common to encounter situations where the process pipe will remain momentarily partially filled due to certain hydraulic conditions. Examples of this include discharge to the atmosphere (lack of back pressure), insufficient line pressure, gravity flow applications, etc. (see figure above)

To eliminate the negative effect of these situations on the performance of Magnetoflow® meters, a few guidelines should be observed:

- Avoid installing the detector in the highest point of the pipe line.
- Do not install the detector in vertical, downward flow sections of the pipe.
- On-Off valves should ALWAYS be located on the downstream side of the detector.
- Select the recommended vertical orientation when ever possible.
- Make sure the selected detector size complies with the application flow rate. Do not oversize pipe line and detector size.

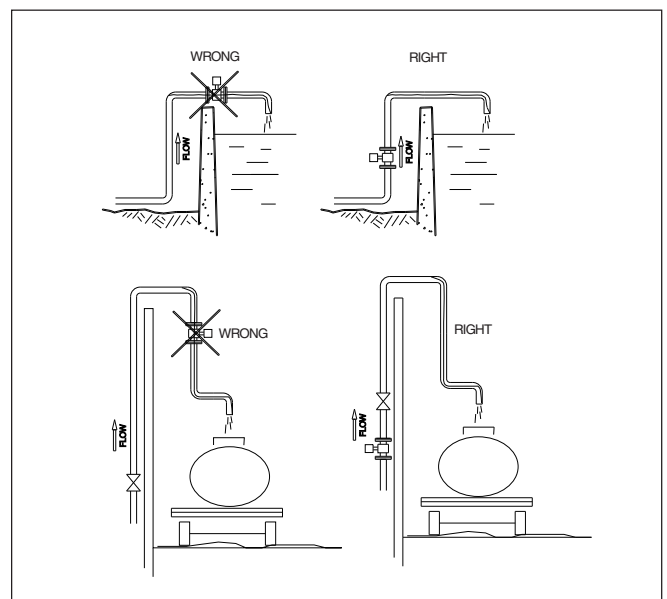

ELECTRICAL CONNECTIONS

The Magnetoflow® 7500S electronic converter is enclosed in a water tight (NEMA 4X) stainless steel enclosure. A pair of 1/2" NPT water-tight cord grips is provided for the electrical connections.

Do not remove these cord grips unless you replace them with water-tight conduit adapters or similar connectors. Failure to comply with this requirement will void the Badger Meter, Inc. warranty.

To access the electrical connection, remove the cover of the amplifier by loosening the four (4) mounting screws.

For all wiring, use 18 or 20 Awg wire.

Upon assembly and installation of the cable with cord grip, make sure the cord grip is tight. In addition, to prevent possibility of moisture entering the enclosure, especially during a washdown operation, loop the cable down before entering the cord grip. (See figure.) If the meter is installed

in a vertical pipe such that the cord grips are now on the top of the assembly, it is recommended that a silicone sealant be put around the cord grips after installation to further assist in prevention of moisture to the inside of enclosure during a washdown operation.

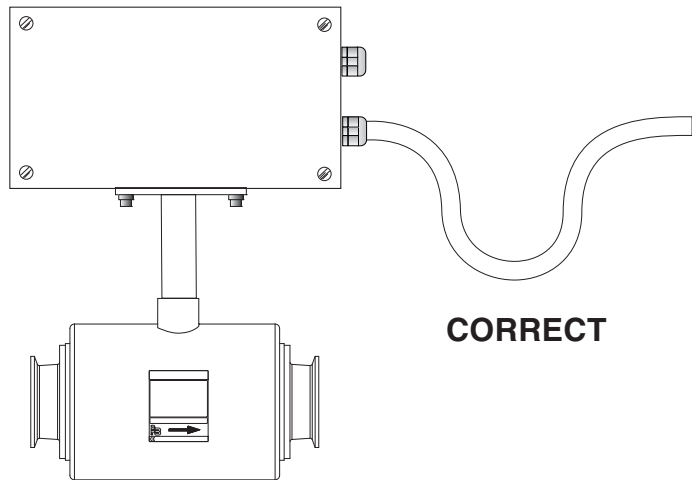
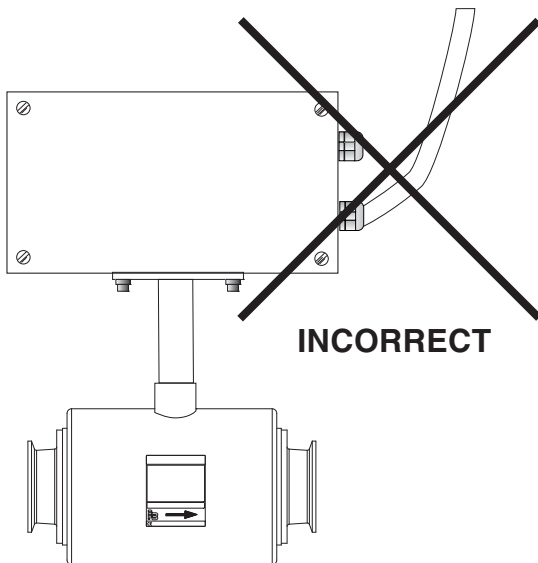

POWER SUPPLY CONNECTION

⚠ WARNING

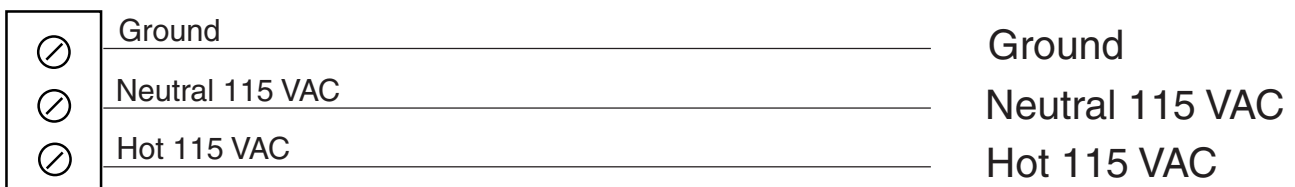

WIRING TO PC100 CONTROLLER

For connection of the open collector scaled pulse output from the Model 7500S to the PC 100 Controller, follow the diagram below:

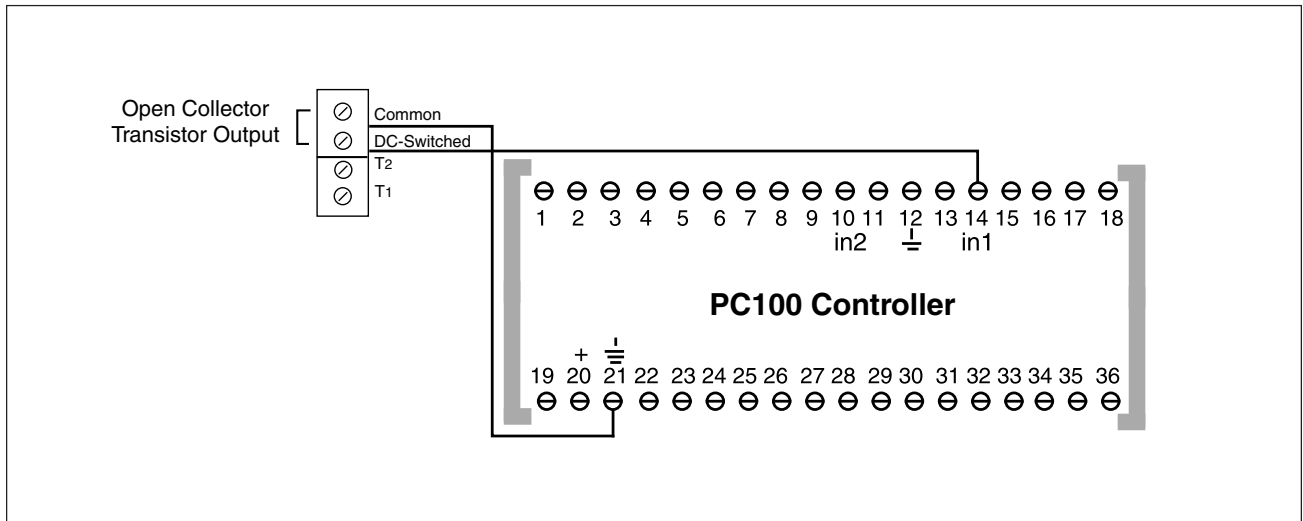

WIRING TO ER-8 TOTALIZER / RATE INDICATOR

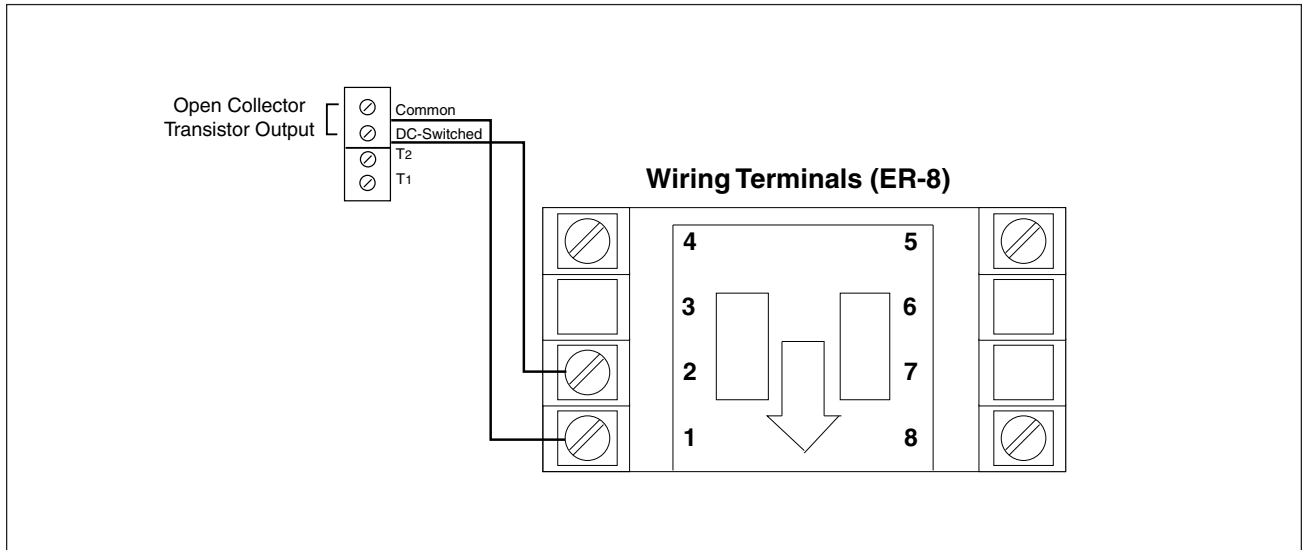

1. DC Common
2. Count Input - NPN Signal 280 Hz. or Dry Contact 95 Hz.
3. Not Used
4. Remote Reset - Resets count value when switched to common
5. Front Panel Program Enable - Allows access to program mode when connected to common
6. Not Used
7. Not Used
8. DC Supply Input - 10 to 28 VDC for backlighting.

CALIBRATION

The Model 7500S is provided tested and calibrated with a test configuration included with each meter when shipped. If recalibration of your system accuracy may

be required, the Model 7500S provides a feature, using (4) rotary switches, that permits a simple recalibration procedure. (see below)

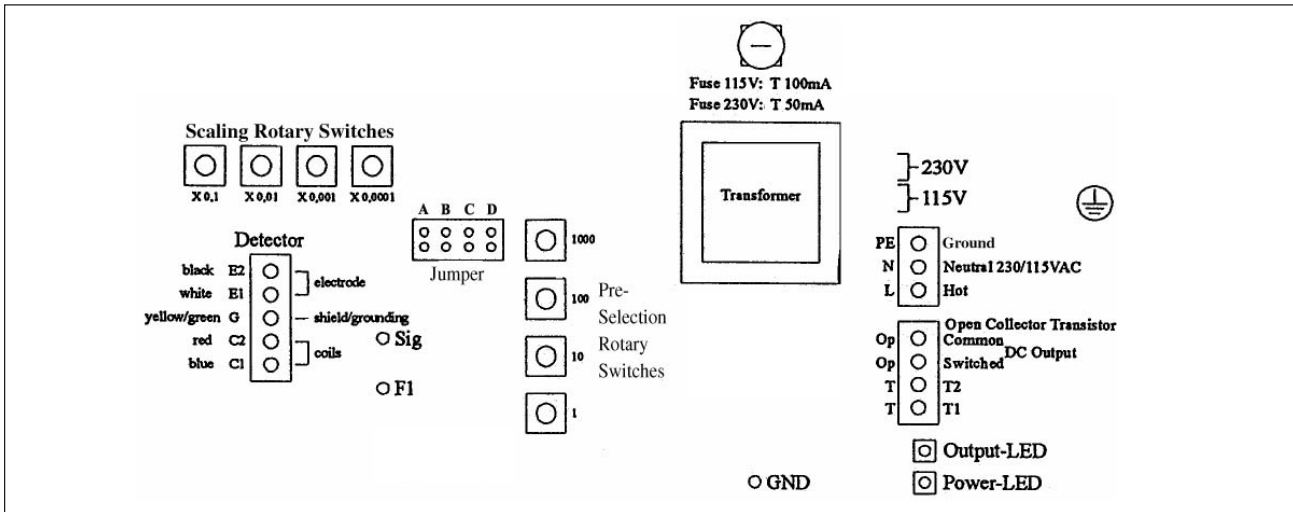

RECALIBRATION PROCEDURE

If it is necessary to recalibrate the meter, this can be done by changing the Scale Factor which is set on the four (4) rotary switches located in the upper left hand corner. (See above figure) To make this change, the following steps are necessary.

- Determine the exact quantity of fluid that actually passed through the meter by using a calibrated volumetric container or by weighing the container.
- Note volume of fluid indicated by meter.
- Note present scale factor on (4) rotary switches.
- Use the following formula to calculate the new Scale Factor for recalibration:

$$\frac{\text{Qty Delivered}}{\text{Qty on Meter}} \times \frac{\text{Old Scale Factor}}{\text{New Scale Factor}} = \text{New Scale Factor}$$

- Enter new scale factor on the rotary switches.
- **Rerun test to verify that the recalibration is correct.**

EXAMPLE:

You have a 3" size meter in your installation. You run a test batch quantity of 238 gallons. The totalizer on the meter indicates 203 gallons. Your present scale factor on the four (4) rotary switches is .2533.

Using the formula:

$$\frac{238}{203} \times .2533 \text{ (Old Scale Factor)} = .2969 \text{ (New Scale Factor)}$$

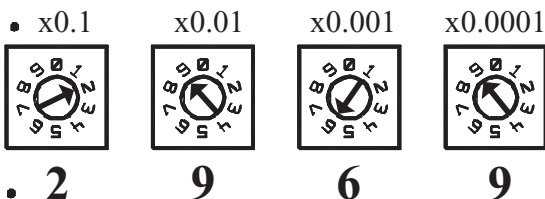

½" Meter (1-30 gpm)	Scaling Factor
1 Pulse Per Gallon	.0500
10 Pulse Per Gallon	.5000
100 Pulse Per Gallon	.5000
500 Pulse Per Gallon	.5000
1 Pulse Per Liter	.5000
1" Meter (3-80 gpm)	
1 Pulse Per Gallon	.5000
10 Pulse Per Gallon	.5000
100 Pulse Per Gallon	.5000
500 Pulse Per Gallon	.5000
1 Pulse Per Liter	.5000
2" Meter (10-315 gpm)	
1 Pulse Per Gallon	.2500
10 Pulse Per Gallon	.2500
1 Pulse Per Liter	.0946
3" Meter (24-690 gpm)	
1 Pulse Per Gallon	.2533
10 Pulse Per Gallon	.2533
1 Pulse Per Liter	.1892
4" Meter (40-1200 gpm)	
1 Pulse Per Gallon	.5000
10 Pulse Per Gallon	.5000
1 Pulse Per Liter	.1892

7500S MAG METER STANDARD SWITCH SETTINGS

½" Meter (1-30 gpm)	Pre Selection Factor	Jumper Position
1 Pulse Per Gallon	1500	D
10 Pulse Per Gallon	1500	D
100 Pulse Per Gallon	0150	D
500 Pulse Per Gallon	0030	D
1 Pulse Per Liter	3965	D
1" Meter (3-80 gpm)		
1 Pulse Per Gallon	6000	D
10 Pulse Per Gallon	0600	D
100 Pulse Per Gallon	0060	D
500 Pulse Per Gallon	0012	D
1 Pulse Per Liter	1585	D
2" Meter (10-315 gpm)		
1 Pulse Per Gallon	0750	C
10 Pulse Per Gallon	0075	C
1 Pulse Per Liter	0075	C
3" Meter (24-690 gpm)		
1 Pulse Per Gallon	0380	B
10 Pulse Per Gallon	0038	B
1 Pulse Per Liter	0038	B
4" Meter (40-1200 gpm)		
1 Pulse Per Gallon	0250	A
10 Pulse Per Gallon	0025	A
1 Pulse Per Liter	0025	A

PRE-SELECTION SWITCHES

On the board diagram on the previous page, note the position of the (4) "Pre-Selection Rotary Switches." As per the above chart, these switches are set at the factory per meter size and general magnitude of pulse output desired. If a change of resolution (pulse output value) is required, change the Pre-Selection Switches to above values.

Example:
Setting of Pre-
selection Rotary
Switch Settings

3" Meter with
1 pulse/gallon = 0380

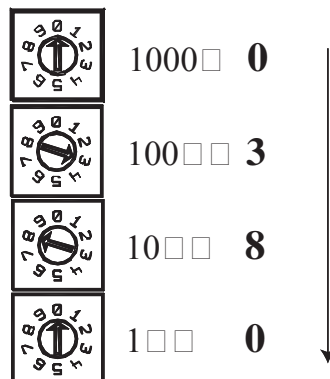

JUMPER LOCATION

Please note the jumper area in the illustration. There are (4) jumper positions designated by A, B, C, and D. **The jumper must be located in the correct position for the respective meter size.**



www.badgermeter.com

Copyright © Badger Meter, Inc. 2009. All rights reserved.

Due to continuous research, product improvements and enhancements, Badger Meter reserves the right to change product or system specifications without notice, except to the extent an outstanding bid obligation exists.



®

BadgerMeter, Inc.

P.O. Box 245036, Milwaukee, WI 53224-9536

Telephone: (414) 355-0400 / (800) 456-5023

Fax: (414) 355-7499 / (866) 613-9305

www.badgermeter.com