

Models Summator/Splitter, Summator/Converter, Splitter, Converter and Hi-Lo Harness

For Turbo Series and Compound Series Meters

Installation Data

DESCRIPTION

The Summator/Splitter, Summator/Converter and Hi-Lo Harness models are designed to work with Badger Meter's Recordall® Compound Series Meter and the Splitter and Converter models with the Recordall Turbo Series Meters. In all cases, connection takes place between the various components by the use of the same style connector which is an exclusive Badger Meter design. This connector provides flexibility in system selection, is tamper proof and is also submersible.

Connector pin locations are arranged so if noncompatible products are connected together, the Badger Meter electronic reading product will not function or will give a tamper alarm.

All of the connection components have alignment keys to assist in the assembly process. The cable entry into the connector is sealed with a polyurethane potting material. The connector halves are sealed to each other with an O-Ring. Grease is used to fill the interior connector cavity to prevent contact corrosion. The connector halves are locked together with a 1/6" turn of the Lock Band. When turned and locked into this final position, it can no longer be rotated to the unlocked position. It can only be removed by breaking it at one of its score marks with a screwdriver or similar tool. The connector can be reassembled with the use of a new Lock Band.



Figure 1. Summator models mounted to RTR Recordall Compound Register

When shipped, the Summator/Splitter model is not connected to the RTR® register and the output wires are in a shorted condition or "tamper condition" as it relates to the lead line tamper feature on MRT products. This tamper condition will clear within 5 minutes after connection. If immediate clearing is desired, simply run up (1) one count on the RTR register.

INSTALLATION INSTRUCTIONS

The following instructions are to assist you in the connection process if necessary. Most of the products, when purchased with a complete system, will be shipped with these connections complete.

Keep all parts clean prior to assembly. Any dirt or water within the connector enclosure can cause corrosion of the contacts which will reduce connector life.

When connecting either of the following styles, first apply grease from the small tube in the kit into the terminal cavity of the male connector. The tube contains the correct quantity of grease to use so be sure to dispense all of it into the connector. A pliers may be helpful to assist in squeezing out the last quantity of grease.

Connecting a Male Connector to the Female Connector on the Summator/Converter/Splitter Unit:

- 1) Drop the locking band onto the female connector with the short alignment mark up and position the band so that the long alignment mark is lined up with the alignment mark at the base of the female connector.
- 2) Insert the male connector into the female connector, again lining up the long alignment marks on each component. The insertion operation may require significant force to displace the excess grease from the connector cavity.
- 3) With the connector halves forced together, turn the locking band to align its short mark with the long alignment marks on the connector halves. Molded tabs on locking band and male connector will assist in this turning operation. When in the correct final position, you should hear a click indicating it is locked.

Connecting a Female Connector to the Male Connector on the Summator/Converter/Splitter Unit:

- 1) Drop the locking band onto the male connector with the short alignment mark down and position the band so that the long alignment mark is lined up with the alignment mark along the side of the base of the male connector.
- 2) Insert the female connector into the male connector, again lining up the long alignment marks on each component. The insertion operation may require significant force to displace the excess grease from the connector cavity.
- 3) With the connector halves forced together, turn the locking band to align its short mark with the long alignment marks on the connector halves. It may require a pliers to rotate the band to its final position. When in the correct final position, you should hear a click indicating it is locked.

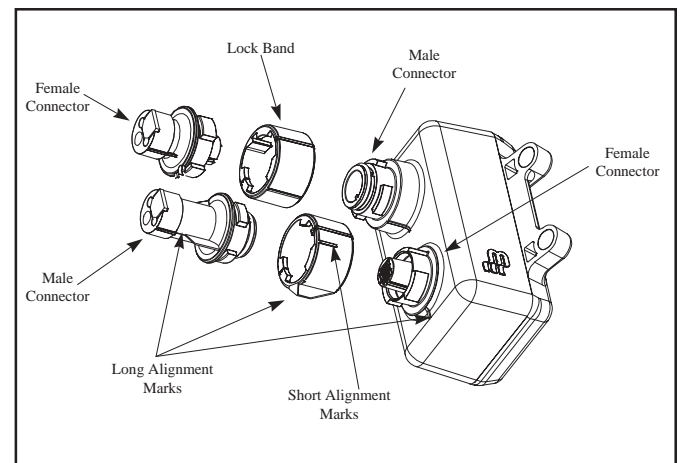
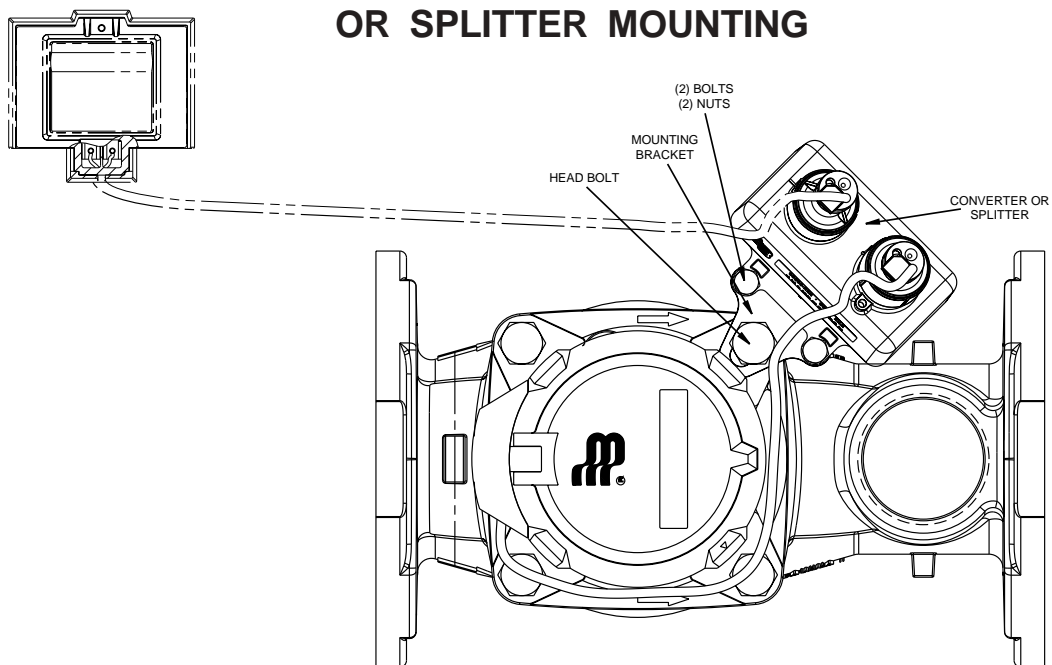

Figure 2.

COMPOUND SERIES RTR'S WITH SUMMATOR/SPLITTER OR SUMMATOR/CONVERTER MOUNTING



TURBO SERIES WITH CONVERTER OR SPLITTER MOUNTING



RTR® and Recordall® are registered trademarks of Badger Meter, Inc.



Please see our website at
www.badgermeter.com
for specific contacts.

Due to continuous research, product improvements and enhancements, Badger Meter reserves the right to change product or system specifications without notice, except to the extent an outstanding bid obligation exists.



BadgerMeter, Inc.

P.O. Box 245036, Milwaukee, WI 53224-9536
(800) 876-3837 / Fax: (888) 371-5982
www.badgermeter.com