

Type 884

1/4", 1/2", 3/4" and 1" Extension Bonnet Valve Assembly RESEARCH® Control Valves

Technical Brief

DESCRIPTION

The Type 884 extended bonnet globe control valve is available in varying lengths for 1/4" thru 1" line sizes. It is specifically designed for control of extremely cold or hot fluids and gases. In cryogenic applications, the bonnet length serves to extend the packing area, as well as allow room for insulation around the body and bonnet. The design also facilitates cold box mounting. A casing flange is available as an option if sealing to the cold box is required. Other models are available to facilitate removal of the innervalve and seat from outside the cold box (Type CBX). In hot applications, the extended bonnet allows the standard TFE packing to be isolated from high temperatures. The factory should be consulted when service temperature exceeds 800F (426C). Note: In all applications, the TFE ring packing should not be used when the temperature at the packing is below -120F (-84C) or above +350F (176C).

APPLICATIONS

The Type 884 valve is widely used in industrial applications, research, and process pilot plants for liquids and gases when temperatures are in the cryogenic range. The 14" (356mm) bonnet normally performs well for temperatures down to -450F (-232C) such as: liquid CO₂, hydrogen and nitrogen. Bonnet lengths up to 60 inch (1524mm) can be supplied. Also available are extended bellows seal bonnets for applications where stem sealing is critical.

MATERIALS OF CONSTRUCTION

Standard: 316 SST

Optional: Monel®, Alloy C-4/C-276

Innervalve:

Standard: 316 SST

Optional: Monel, Alloy C 276, Stellite® 316 SST, 316 and TFE (some types and sizes)

Packing: Standard- TFE CV rings. Optional-Grafoil®, REK®

Actuator: Standard-Aluminum with Epoxy Paint,

Optional - 316 SST (in standard version 1/2" thru 1")

ACTUATOR

Standard: Air to open, fail close, Air to close, fail open

Optional: Same as above but with top mounted positioner

Standard Signals (psig): 3-15, 3-27, 6-30

Optional Signals (psig): With positioner— 3-9, 9-15

Accessories: Filter regulator, gauges, I/P converter, handwheel (on 754 or 755 only) limit switches, solenoids



STANDARD FEATURES

- Wide range of interchangeable trims
- Choice of linear or equal percent on most trims
- TFE chevron ring packing
- ANSI Class IV shutoff (size "O" and larger)
- Guided innervalve

OPTIONAL FEATURES

- Flanges
- Shorter and longer extension lengths
- Socket weld and butt weld ends
- Bellows stem seal
- Casing flange
- Angle pattern body
- Graphite packing
- REK packing (Reduced Emissions)

GRAFOIL® is a registered trademark of Grafftech Inc.

Monel® is a registered trademark of Inco Alloys International, Inc.

REK® is a registered trademark of Badger Meter, Inc.

RESEARCH® is a registered trademark of Badger Meter, Inc.

Stellite® is a registered trademark of Haynes Stellite Company.



BadgerMeter, Inc.

940928

11-00

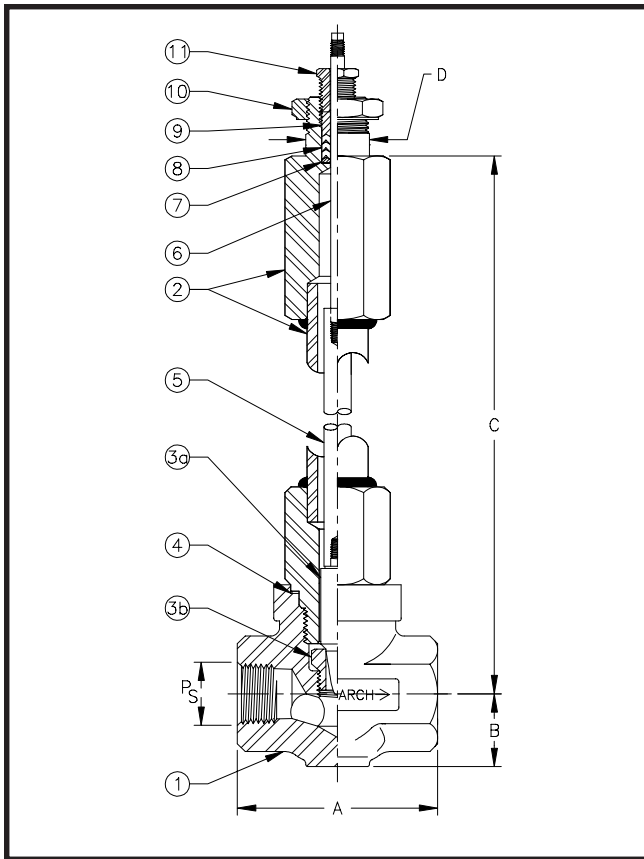

Description of Items

1. Valve Body
2. Bonnet assembly (welded)
3. Innavalve (trim) Set
3A: Plug assembly
3B: Seat
4. Body-Bonnet gasket
5. Lower stem
6. Upper stem
7. Packing adaptor
8. Packing-Chevron rings
9. Packing follower
10. Lock nut- 1/4" unit- 7/8" hex, 1/2", 3/4", 1" = 1-1/8" hex
11. Packing gland

Dimensions

PS	1/4"	1/2"	3/4"	1"
A	2.12" (54 mm)	2.75" (70 mm)	3.37" (86 mm)	4.00" (102 mm)
B	0.68" (17 mm)	1" (25 mm)	1.18" (30 mm)	1.5" (38 mm)
C	14" (356 mm)	14" (356 mm)	14" (356 mm)	14" (356 mm)
D	0.625" (16 mm)	0.875" (22 mm)	0.875" (22 mm)	0.875" (22 mm)
Stroke	0.437" (11 mm)	0.562" (14 mm)	0.562" (14 mm)	0.562" (14 mm)

Innavalve Chart

Valve Size	Trim Size	Max. Cv	Orifice Dia. (in.)	Orifice Area (sq. in.)	Nominal Rangeability Linear	Nominal Rangeability Equal %
1"	6.0	6.0	0.6250	0.3068	50:1	60:1
1"	5.0	5.0	0.6250	0.3068	50:1	60:1
1"	4.5	4.5	0.5000	0.1963	50:1	60:1
3/4"-1"	4.0	4.0	0.4375	0.1503	50:1	60:1
3/4"-1"	3.5	3.5	0.4375	0.1503	50:1	60:1
1/2"-1"	A	2.5	0.3750	0.1104	40:1	50:1
1/2"-1"	B	2.0	0.3750	0.1104	40:1	50:1
1/2"-1"	C	1.25	0.2810	0.0620	40:1	50:1
1/2"-1"	D	0.8	0.2500	0.0491	40:1	50:1
1/2"-1"	E	0.5	0.2500	0.0491	40:1	50:1
1/4"-1"	F	0.32	0.1560	0.0191	30:1	40:1
1/4"-1"	G	0.2	0.1560	0.0191	30:1	40:1
1/4"-1"	H	0.13	0.1560	0.0191	30:1	40:1
1/4"-1"	I	0.08	0.1560	0.0191	30:1	40:1
1/4"-1"	J	0.05	0.1560	0.0191	30:1	40:1
1/4"-1"	K	0.03	0.0860	0.0058	25:1	NA
1/4"-1"	L	0.02	0.0860	0.0058	25:1	NA
1/4"-1"	M	0.01	0.0860	0.0058	25:1	NA
1/4"-1"	N	0.006	0.0860	0.0058	25:1	NA
1/4"-1"	O	0.003	0.0860	0.0058	25:1	NA
1/4"-1/2"	P-1	0.002	0.0625	0.0031	15:1	NA
1/4"-1/2"	P-2	0.0013	0.0625	0.0031	15:1	NA
1/4"-1/2"	P-3	0.001	0.0625	0.0031	15:1	NA
1/4"-1/2"	P-4	0.0006	0.0625	0.0031	15:1	NA
1/4"-1/2"	P-5	0.0004	0.0625	0.0031	15:1	NA
1/4"-1/2"	P-6	0.00027	0.0625	0.0031	15:1	NA
1/4"-1/2"	P-7	0.00018	0.0625	0.0031	15:1	NA
1/4"-1/2"	P-8	0.00012	0.0625	0.0031	15:1	NA
1/4"-1/2"	P-9	0.00008	0.0625	0.0031	15:1	NA
1/4"	P-10					
1/4"	P-11					
1/4"	P-12					
1/4"	P-13					
1/4"	P-14					
1/4"	P-15					
1/4"	P-16					
1/4"	P-17					
1/4"	P-18					

Consult the factory for these innervalve sizes.

Pressure Verse Temperature (316 SST)

Temperature °F (°C)	1/4" psig (barg)	1/2" psig (barg)	3/4" psig (barg)	1" psig (barg)
-450 (-232)	2500 (172)	2500 (172)	1500 (103)	1500 (103)
100 (38)	2500 (172)	2500 (172)	1500 (103)	1500 (103)
200 (93)	2500 (172)	2375 (163)	1450 (103)	1450 (103)
300 (149)	2375 (163)	2155 (148)	1325 (91)	1325 (91)
400 (204)	2095 (144)	1930 (133)	1175 (81)	1175 (81)
500 (260)	2000 (138)	1820 (125)	1100 (76)	1100 (76)
600 (316)	1910 (132)	1735 (119)	1050 (72)	675 (46)
700 (371)	1820 (125)	1655 (114)	840 (58)	250 (17)
800 (427)	1790 (123)	1625 (112)	575 (40)	
900 (482)*	1420 (101)	1595 (110)		
1000 (538)*	580 (40)	930 (64)		
Recommended Bonnet Torque	37 lbs.-ft. (48 N-m)	122 lbs.-ft. (159 N-m)	290 lbs.-ft. (378 N-m)	345 lbs.-ft. (450 N-m)

For ratings on other materials, consult the factory.
For maximum allowable pressure drops, consult the factory or the technical selection guide for information.

NOTE: The pressure/temperature ratings listed above are based on material thickness at the joint between the body and the bonnet. When the proper torque levels are used, the valve gasket will seal under normal static conditions. The above listed torque levels were used in hydrostatic tests at the factory at 70 deg. F at maximum body rating and were found to provide acceptable sealing. Other factors such as high or cyclic temperatures, light process gases, or poor gasket surfaces can affect seal integrity. Under such conditions, the only way to be assured of tight sealing is to perform a test under the actual process conditions.

Please note that the above chart is not intended as an indication of optimum function or suitability for control service. Other charts are available to assist in the choosing of valve type, bonnet type, trim type and actuator.

* depending on industry design standard requirements; consult factory.



Please see our website at www.badgermeter.com for specific regions and contacts.

Due to continuous research, product improvements and enhancements, Badger Meter reserves the right to change product or system specifications without notice, except to the extent an outstanding bid obligation exists.



BadgerMeter, Inc.

P.O. Box 581390, Tulsa, Oklahoma 74158
(918) 836-8411 / Fax: (918) 832-9962

www.badgermeter.com