

External suppressors should be installed in industrial circuits controlling inductive loads. The use of external suppressors will extend the life of relay contacts and will reduce the possibility of electronic instruments and controls being adversely affected by electrical noise. Typical inductive loads that require suppression include, but are not limited to: solenoid valves, control relays, motor starters and small motors.

The wiring diagram which follows illustrates a typical configuration. Wherever possible, the suppressor should be connected directly on the coil terminals of the load device being suppressed. In cases where this is not possible, connect the suppressor at the terminal strip closest to the load being suppressed. The suppressor should be connected in parallel with the inductive load.

The suppressor shown effectively suppresses the typical inductive devices found in 120 and 240 VOLT industrial control circuits. Multiple suppressors can be wired in parallel for use with large inductive loads.

**Surge Suppressor**

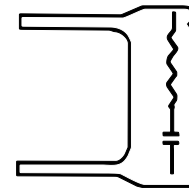

**Equivalent Circuit**

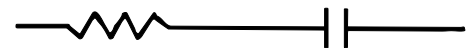

**150 Ω  
.5 Watt**

**.25 μf  
600V**

**For use in AC and DC  
circuits up to 240V.**

**INDUCTIVE LOAD OPERATED FROM THE PC100 INTERNAL RELAY CONTACTS**

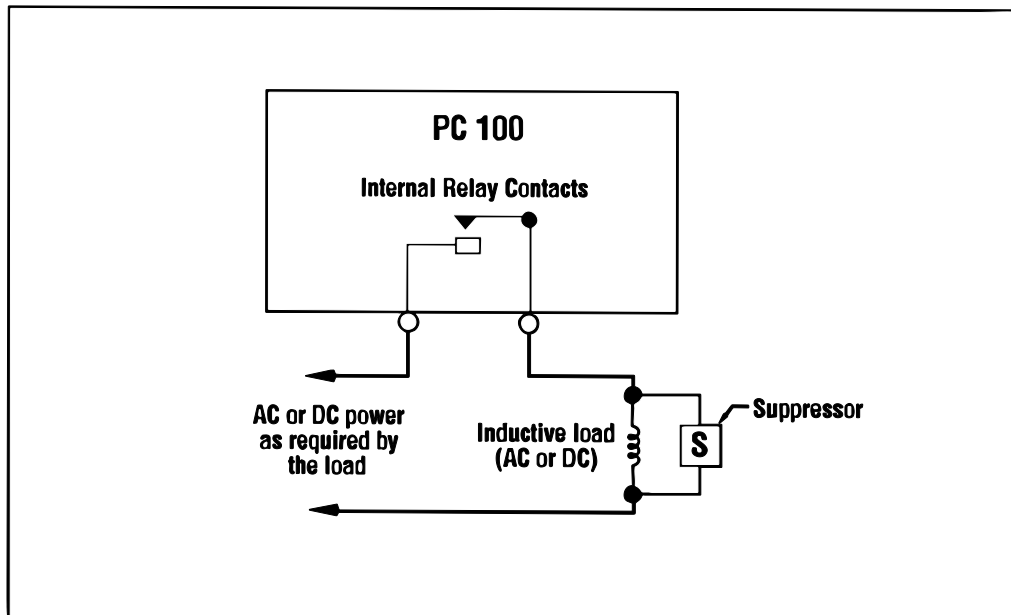

**IOM-072-01**  
Part No. 53400-072

7-01



Please see our website at  
**www.badgermeter.com**  
for specific regions and contacts.



**BadgerMeter, Inc.**

P.O. Box 245036, Milwaukee, WI 53224-9536  
Telephone: (414) 355-0400 / (877) 243-1010  
Fax: (414) 355-7499 / (866) 613-9305  
www.badgermeter.com