

GENERAL

The Badger® MEASURE RITE® Truck Meter is used for accurately measuring and dispensing water for premixed batches at the job site. The truck meter helps minimize mix errors and batch waste.

OPERATION

The ladder platform area is the ideal mounting location for the truck meter, just upstream (and in line with) the water manifold. Verify that any movement of the platform will not cause the meter to contact the barrel or other components.

APPLICATIONS

The truck mount meter will allow the user to accurately measure the amount of added water for adjusting slump.

FEATURES

- Air slug tolerant
- Highly rugged and durable
- Compact and user friendly
- Easy to install
- Easy to calibrate
- Single button operation

MATERIALS

Meter Body: Bronze
Impeller: 316SST
Shaft: Tungsten Carbide
Bearings: Torlon (high performance polymer)
Electronics Housing: Coated Aluminum
Window: Tempered Glass

PRESSURE RATING

400 psig (Class 250)
225 psig at 180° F
Max Ambient Temperature 140° F

METER SIZE & FLOW RANGE

3/4" NPT: 5-30 GPM
1" NPT: 15-60 GPM
1 1/4" NPT: 15-90 GPM
1 1/2" NPT: 21-125 GPM
2" NPT: 35-200 GPM

ACCURACY

- +/- 1% or better (within flow range) when properly calibrated
- Power requirement: 9-32VDC



OPTIONS

Mounting Bracket
Ball Valve (mount 6" downstream of meter)
Upstream Strainer (60 Mesh recommended at least 12" upstream of valve)
Vertical Front Panel Rotation
1" and 2" available in 316 SST
Tees along with a variety of bearings and seals material
Consult Factory

DEPARTMENT OF TRANSPORTATION STANDARDS

Truck meter meets Alabama DOT specifications
ALDOT-407-01 and New York Spec Truck Mixer 501-3-04
Requirements.

Badger® and MEASURE RITE® are registered trademarks of Badger Meter, Inc.



DIMENSIONS

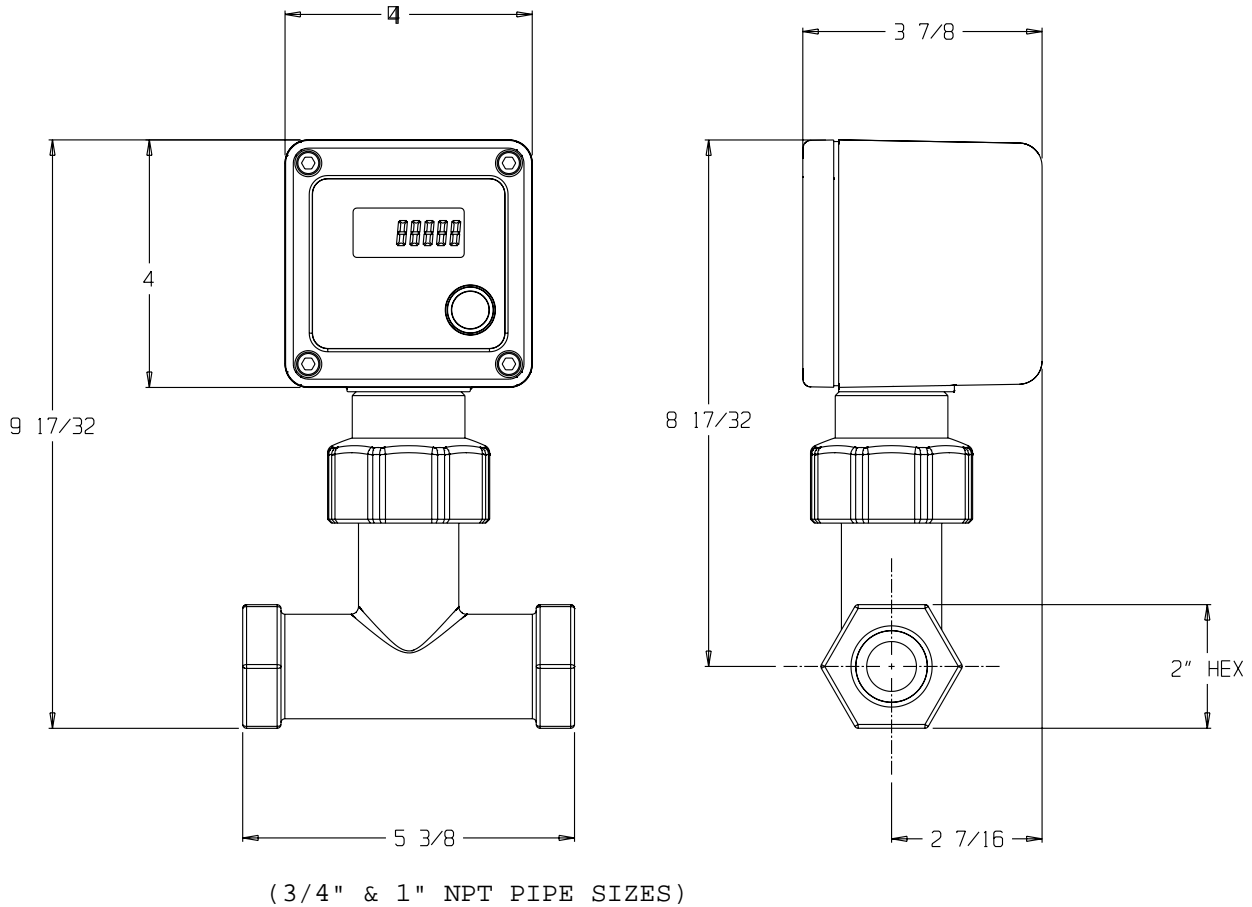

Please see our website at
www.badgermeter.com
for specific contacts.

Due to continuous research, product improvements and enhancements, Badger Meter reserves the right to change product or system specifications without notice, except to the extent an outstanding bid obligation exists.



BadgerMeter, Inc.

6116 East 15th Street, Tulsa, OK 74112

Telephone: (800) 364-9876 / Fax: (918) 832-9962

www.badgermeter.com