

**RADIO FREQUENCY FLUID MANAGEMENT SYSTEM OVERVIEW**

Badger Meter's Radio Frequency Fluid Management System (RF-FMS) consists of an A/C powered keypad and RF-equipped meters. The product has been designed to offer greater control over the dispensing of fluids with significant reductions in installation costs and the associated hardware common to most hard-wired systems today. Dispense information and authorization is communicated from the keypad to the meter with actual dispense information being communicated back to the keypad utilizing 902-928 Mhz frequency hopping spread spectrum radio communications.

The Badger EPM-2 RF Meter is designed specifically to meter and dispense bulk fluids for servicing automobiles, trucks, buses, construction equipment, and similar applications. The meter is lightweight, rugged and has a comfortable grip. The meter is designed specifically to dispense motor oils (S.A.E. 5-50), gear oils (S.A.E. 80-240), automatic transmission fluid, antifreeze (Ethylene Glycol) solution, and hydraulic fluid.

A superior rugged, shock-resistant design for demanding environments.

Badger's EPM-2 RF meter uses 4 replaceable AA batteries and is calibrated at the factory. The meter can also be recalibrated easily in the field for a fluid of different viscosity.

The EPM-2 RF meter is equipped with RF (radio frequency) communications to communicate with a fluid management system keypad to get authorization and dispense information.

Once a work order has been entered at the keypad, the operator simply pushes the RESET button on the meter to start communications between the meter and the keypad. The meter receives authorization from the keypad to unlock, along with the dispense batch quantity. When the trigger is pulled the pre-set dispense batch quantity dispenses.

The meter automatically shuts off when the dispense batch quantity has been reached.

A "Top Off" feature allows additional fluid to be dispensed and tracked after the batch quantity has been dispensed.

Upon completion of the dispense, the operator presses the RESET button. The meter then locks, prohibiting any unauthorized dispense of fluid to occur, and the dispense quantity is sent to the keypad.

- Fleet Maintenance Shops
- Industrial Assembly
- Quick Lube Facilities
- Dealerships
- Construction and Mining Equipment
- General Automotive Service Centers
- Specialty Service and Repair Shops



**FCC ID: GIF-RFEPM  
FCC CERTIFIED, PART 15, SUBPART C**

This device complies with Part 15 of the FCC Rules. Operation is subject to the following two conditions: (1) this device may not cause harmful interference, and (2) this device must accept any interference received, including interference that may cause undesired operation.

- Oval Gear Driven Meter
- Durable
- Lightweight
- Large, Easy-to-Read LCD Display
- Ease of Operation
- Totalization in Liters and Gallons
- Dispensing Measurement in Liters, Quarts, Pints, Gallons
- Dispense Top Off Feature
- Unauthorized Dispense Lock Out Feature
- Max. Totalizer Number: 99,999 Gallons or Liters
- Max. Dispense Volume: 99,999 Units
- Max. Preset Volume: 99.9 Units
- Calibration Factor for Different Fluids
- Changeable Units of Measure
- Total and Resettable Total
- Minimum 20,000 Cycles on Battery Life
- Low Battery Indicator
- Low Battery Safety Lock Out Feature
- Ability to Save Settings if Power Interrupted
- Uses 4 Standard AA Batteries
- In-Line Swivel Standard With All Meters
- Engraving and/or Labels Available
- Automatic Shut-Off at Preset Amount
- Emergency Electrical Override
- Precision Control Valve Operation



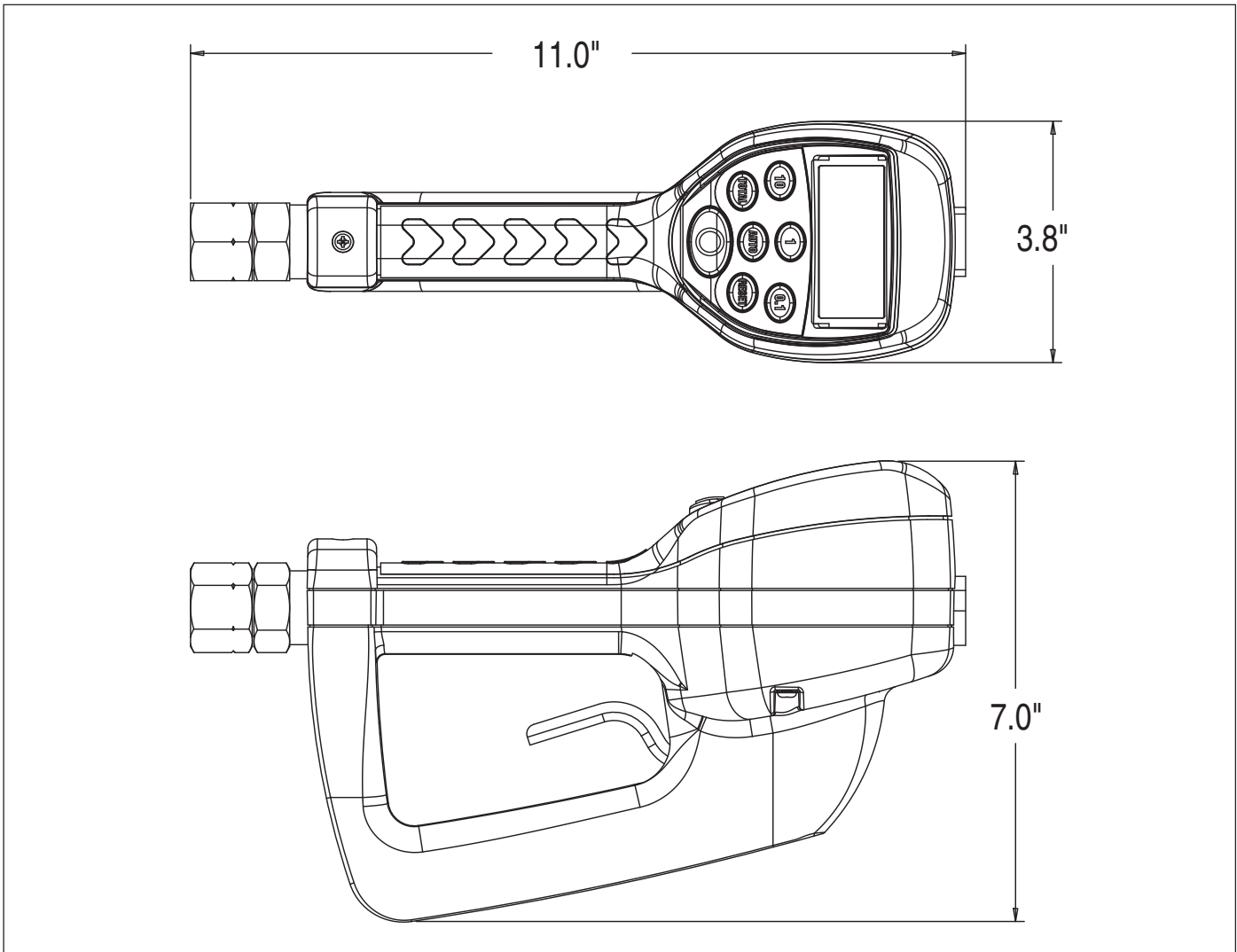

## SPECIFICATIONS

	English	Metric
Maximum Flow *	10 gpm	38 lpm
Minimum Flow *	0.25 gpm	1 lpm
Operating Pressure (Maximum)	1000 psi	67 bar
Operating Pressure (Minimum)	5 psi	.35 bar
Operating Temperature (Maximum)	120° F	50° C
Operating Temperature (Minimum)	20° F	- 5° C
Accuracy Oils	+/- 0.5%	+/- 0.5%
Accuracy Antifreeze	+/- 1.5%	+/- 1.5%
5-Digit LCD Display	Quarts, Pints, Gallons	Liters
Inlet and Outlet Connections	½" NPT	½" BSPP

\* Tested with DTE-25 motor oil at ambient temperature. Min.-Max. flow range will vary with fluid viscosity.



Please see our website at  
[www.badgermeter.com](http://www.badgermeter.com)  
 for specific regions and contacts.

Copyright © Badger Meter, Inc. 2009. All rights reserved.

Due to continuous research, product improvements and enhancements, Badger Meter reserves the right to change product or system specifications without notice, except to the extent an outstanding contractual obligation exists.



**BadgerMeter, Inc.**

P.O. Box 245036, Milwaukee, WI 53224-9536  
 Telephone: (414) 355-0400 / (800) 456-5023  
 Fax: (414) 355-7499 / (866) 613-9305  
[www.badgermeter.com](http://www.badgermeter.com)