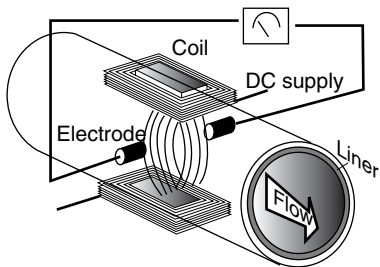

GENERAL

Badger's Magnetoflow line is the result of 35 years of research and field use in electromagnetic flow meters. Based on Faraday's law of induction, these meters can measure almost any liquid, slurry or paste that has a minimum of electrical conductivity. Designed, developed and manufactured under the strictest quality standards, the Magnetoflow meter ranks among the best in the market. Its sophisticated, processor based signal conversion represents the state of the art in the industry with accuracies of 0.25% or better. The wide selection of liner and electrode materials insures maximum compatibility and minimum maintenance over a long operating period.

OPERATION

The flow meter is basically a stainless steel tube lined with a nonconductive material. Outside the tube two DC powered electromagnetic coils are positioned diametrically opposing each other. Perpendicular to these coils, two electrodes are inserted into the flow tube. When the coils are energized, a magnetic field is created across the whole diameter of the pipe. When a conductive fluid flows through this magnetic field, a voltage is induced across the electrodes. This voltage is directly proportional to the average flow velocity of the fluid and is picked up by the two electrodes. This induced voltage is then amplified and processed digitally by the converter to produce a very accurate analog or digital signal. The signal can then be used to indicate flow rate, totalization or to communicate to remote sensors and controllers. The main advantages of this technology are that with no parts in the flow stream, there is no pressure loss, the accuracy is not affected by temperature, pressure, viscosity, density or flow profile and with no moving parts there is practically no maintenance required.

**APPLICATION**

Because of its inherent advantages over other more conventional technologies, this meter can be used in the majority of industrial flow applications. Whether the fluid is water or something highly corrosive, very viscous, contains a moderate amount of solids or requires special handling, this meter will be able to accurately measure it. Today Magnetoflow meters are successfully being used in most industries including food and beverage, pharmaceutical, water and wastewater, and chemical.

**Magnetoflow® Flanged****FEATURES**

- 0.25% accuracy independent of fluid viscosity, density and temperature
- Unaffected by most solids contained in fluids
- Pulsed DC magnetic field for zero point stability
- No pressure loss for low operational costs
- Long life corrosion resistant liners
- Calibrated in state of the art facilities
- Integral and remote signal converter availability
- Optional grounding rings or grounding electrode
- Measurement largely independent of flow profile
- NSF listed

Electrodes

The two measuring electrodes, when looking from the end of the meter into the inside bore, are positioned at 3 o'clock and 9 o'clock. Badger Meter's Magnetoflow Mag meters have an "Empty Pipe Detection" feature. This is accomplished by the use of a third electrode that is positioned between 12 o'clock and 1 o'clock in the meter. At any time this electrode is not covered by fluid, (for a minimum of a five second duration), the meter will display an Empty Pipe Detection condition, send out an error message if desired, and stop measuring to maintain accuracy. When the electrode again becomes covered with fluid, the error message will disappear and the meter will continue measuring.

As an option to the use of a set of grounding rings, to assure proper grounding in a given installation a grounding electrode (4th electrode) can be installed in the meter when initially fabricated. The position of this electrode is about 5 o'clock.



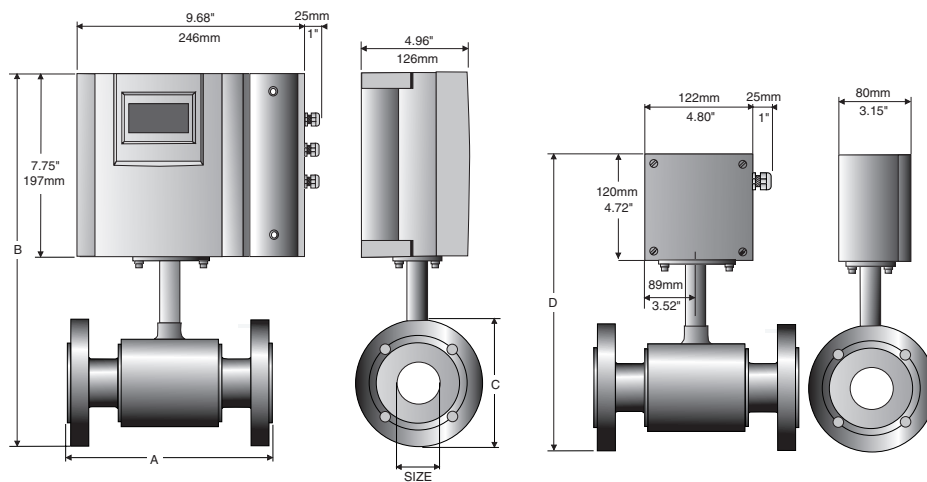

Meter with Primo® Amplifier

Meter with junction box for remote Primo® Amplifier

Size	A		B		C		D		Est. Weight with Primo		Flow Range			
	inch	mm	inch	mm	inch	mm	inch	mm	Lbs	Kg	LPM		GPM	
inch mm	inch	mm	inch	mm	inch	mm	inch	mm			Min	Max	Min	Max
1/4 6	6.7	170	14.0	356	3.5	89	11.4	288	12	5.5	0.063	20	0.02	5
5/16 8	6.7	170	14.0	356	3.5	89	11.4	288	12	5.5	0.114	34	0.03	9
3/8 10	6.7	170	14.0	356	3.5	89	11.4	288	12	5.5	0.177	53	0.05	14
1/2 15	6.7	170	14.0	356	3.5	89	11.4	288	12	5.5	0.416	125	0.11	33
3/4 20	6.7	170	14.2	361	3.9	99	11.5	293	15	6.5	0.75	225	0.2	59
1 25	8.9	225	14.4	366	4.3	108	11.7	298	20	9.0	1.20	350	0.3	93
1 1/4 32	8.9	225	15.2	386	4.6	117	12.5	318	22	10.0	2.00	575	0.5	152
1 1/2 40	8.9	225	15.4	390	5.0	127	12.7	322	23	10.5	3.00	900	0.8	239
2 50	8.9	225	15.9	403	6.0	152	13.2	335	28	12.5	4.70	1400	1	373
2 1/2 65	11.0	280	17.1	434	7.0	178	14.4	366	54	24.5	8	2400	2	631
3 80	11.0	280	17.3	440	7.5	191	14.7	372	56	25.5	12	3600	3	956
4 100	11.0	280	18.4	466	9.0	229	15.7	398	58	26.5	19	5600	5	1493
5 125	15.8	400	19.6	498	10.0	254	16.9	430	60	27.0	30	8800	8	2334
6 150	15.8	400	20.6	524	11.0	279	17.9	456	62	28.0	40	12700	11	3361
8 200	15.8	400	22.5	572	13.5	343	20.4	518	88	40.0	75	22600	20	5975
10 250	19.7	500	26.8	681	16.0	406	24.1	613	180	82.0	120	35300	30	9336
12 300	19.7	500	28.9	734	19.0	483	26.2	666	209	95.0	170	50800	45	13444
14 350	19.7	500	30.8	782	21.0	533	28.2	716	260	118	230	69200	60	18299
16 400	23.6	590	33.7	856	23.5	597	31.0	788	308	140	300	90400	80	23901
18 450	23.6	590	35.0	890	25.0	635	32.4	822	402	182	380	114000	100	30250
20 500	23.6	590	38.2	969	27.5	699	35.5	901	495	225	470	140000	125	37346
22 550	23.6	590	39.6	1005	29.5	749	36.9	937	525	238	570	170000	150	45188
24 600	23.6	590	42.2	1071	32.0	813	39.5	1003	554	252	680	200000	180	53778
28 700	23.6	590	46.2	1173	36.5	927	44.0	1118	650	295	920	275000	240	73100
30 750	31.5	800	48.3	1228	39.0	984	45.7	1161	704	320	1060	315000	280	84000
32 800	31.5	800	52.2	1325	41.4	1015	49.5	1257	770	350	1200	361000	320	95600
36 900	31.5	800	55.3	1405	46.0	1168	54.1	1374	850	386	1500	457000	400	121000
40 1000	31.5	800	60.0	1525	50.2	1230	57.4	1457	924	420	1900	565000	500	149300
42 1050	36.0	914	66.0	1675	53.0	1346	63.4	1610	1100	500	2100	620000	550	164600
48 1200	39.4	1000	69.9	1775	59.4	1455	67.2	1707	1210	550	2700	814000	720	215100
54 1400	39.4	1000	78.5	1995	68.4	1675	75.9	1927	1364	620	3700	1100000	980	292700

SPECIFICATIONS - Detector

Flow Range: 0.1 - 39.4 fps (0.03-12 m/s)

Sizes: 1/4" to 54" (16 to 1400 mm)

Min. Conductivity: ≥ 5 micromhos/cm

Accuracy:

± 0.25% accuracy of rate from 1-39.4 fps.

± 0.5% accuracy of rate from 0.1-1.0 fps.

Electrode Materials: Standard: Alloy C

Optional: 316 Stainless Steel, Gold/Platinum

Plated, Tantalum, Platinum/Rhodium

Liner Material: PFA up to 3/8", PTFE 1/2" thru

24", Soft and Hard Rubber from 1" to 54",

Halar® from 14" to 40"

NSF Listed: Models with Hard Rubber Liner 4"

size and up; PTFE Liner - All sizes.

"Only products bearing the NSF Mark are Certified."

Fluid Temperature:

With Remote Converter:

PFA, PTFE & Halar 311°F, (155°C)

Rubber 178°F, (80°C)

With Meter Mounted Converter:

PFA, PTFE & Halar 212°F, (100°C)

Rubber 178°F, (80°C)

Pressure Limits:

150 psi (10Bar) optional 300psi (20Bar)

Coil Power: Pulsed DC

Ambient Temperature: -4°F to 140°F, (-20°C to 60°C)

Pipe Spool Material: 316 Stainless Steel

Meter Housing Material: Carbon Steel welded

Flanges: Carbon Steel - Standard (ANSI B16.5 Class

150 RF) 316 Stainless Steel - Optional

Meter Enclosure Classification: Nema 4

Optional: Submersible Nema 6P (Remote Amplifier

Required)

Junction Box Enclosure Protection:

(For Remote Converter Option) Powder coated die-

cast aluminum, Nema 4

Cable Entries: 1/2" NPT Cord Grip

Optional Stainless Steel Grounding Rings:

Meter Size

up thru 10"

12" to 20"

Thickness (of one ring)

.135"

.187"

Magnetoflow® and Primo® are registered trademarks of Badger Meter, Inc. Halar® is a registered trademark of Ausimont U.S.A., Inc.

Due to continuous research, product improvements and enhancements, Badger Meter reserves the right to change product or system specifications without notice, except to the extent an outstanding contractual obligation exists.

Please see our website at
www.badgermeter.com
 for specific contacts.



BadgerMeter, Inc.

P.O. Box 245036, Milwaukee, WI 53224-9536

Telephone: (414) 355-0400 / (877) 243-1010

Fax: (414) 355-7499 / (866) 613-9305

www.badgermeter.com