

**GENERAL**

With the Ready-Mix Concrete Plant customers in mind, Badger Meter Inc. developed the Magnetoflow® 7500P Mag Meter, a successful combination of the most advanced electromagnetic flow metering technology with the simplicity and ruggedness of Badger Meter's proven Batching Systems for the Concrete Industry.

Based on Faraday's Law of electromagnetic induction, the Magnetoflow® 7500P Mag Meter can accurately measure and control most of the water batching needs in the Concrete Industry. Its completely open cross-section flow tube design with no moving parts, makes it the ideal metering device for clean, cold and hot, and reclaimed water batching in the ready-mix, precast, prestress and block plants.

Where other metering technologies fail due to the presence of solids in suspension in the process water, Magnetoflow® 7500P is designed to perform for many years of trouble-free operation with an accuracy of  $\pm 0.5\%$  or better.

The built-in "Pulse Scaler" board (a Badger Meter Inc. exclusive proven design), featuring easy-to-use rotary switches for batch accuracy compensation, makes the Magnetoflow® 7500P the most straight-forward metering system in the Concrete Industry.

**OPERATION**

The 7500P Mag meter is a stainless steel flow tube with an internal isolating lining. Two electromagnetic coils are located outside the flow tube, diametrically opposed to each other and protected by a carbon steel housing. Two electrodes, inserted into the flow tube, are positioned "flush" with the internal diameter of the tube and perpendicular to the coils. The coils are energized by a pulsed DC voltage provided by the electronic converter, and a magnetic field is generated across the flow tube section. According to Faraday's law, when conductive liquid flows through this magnetic field of the meter, a voltage is generated in the liquid. This voltage is directly proportional to the liquid flow velocity, and therefore to the actual volumetric flow rate of the liquid. The electronic converter measures this voltage, processes the signal, and provides two digital pulse outputs, scalable to the desired volumetric value. These digital pulse outputs can be connected to a batch controller, a totalizer display unit for monitoring purposes, or to both devices simultaneously.

Magnetoflow® 7500P operation is not affected by a moderate presence of most suspended solids in the liquid, as is the case in concrete reclaimed water. Variations of liquid temperature, viscosity or density have no influence in its principle of operation. A set of convenient, field proven pulse scaler rotary switches are provided for easy and straight-forward batch accuracy compensation.

**7500P Concrete Mag Meter****FEATURES**

- Unaffected by most suspended solids in the liquid.
- Open cross-section design: no pressure loss, no moving parts.
- Standard "Turbo Meter" laying lengths on 2", 3" and 4" sizes, eliminates the need for special piping arrangements.
- Pulsed DC magnetic field for maximum zero point stability.
- Rugged, surface mount technology electronics for reliable, long life operation.
- NEMA 4 standard enclosure.
- Two standard pulse outputs: solid state relay and open collector output, compatible with most of existing Batch Controllers and/or Totalizer Displays.
- Standard  $\pm 0.5\%$  of rate accuracy.
- $\pm 0.2\%$  repeatability.
- Built-in rotary switches for easy batch accuracy compensation.



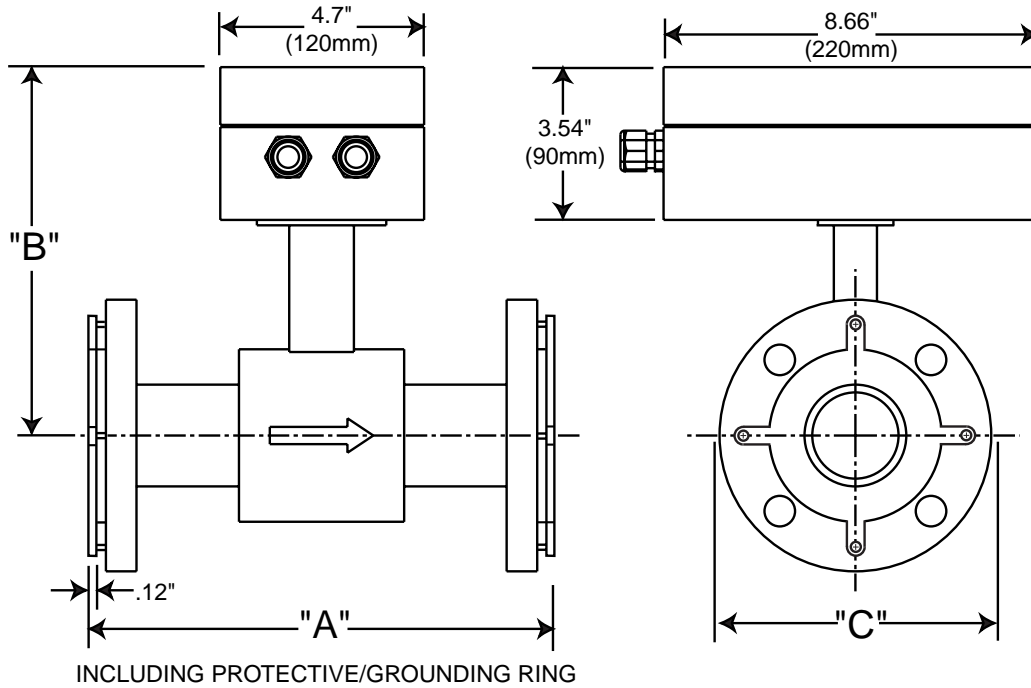

Meter Size	A		B		C		Flow Range GPM	
	inch	mm	inch	mm	inch	mm	min	max
<b>1/2"</b>	6.94	176	8.12	207	3.5	89	1	30
<b>1"</b>	9.14	231	8.12	207	4.3	108	3	80
<b>2"</b>	10.0	254	9.13	232	6.0	152	10	315
<b>3"</b>	12.0	305	9.84	250	7.5	191	24	690
<b>4"</b>	14.0	356	10.12	257	9.0	229	40	1200

**SPECIFICATIONS**

**Detector:**

**Working pressure:** 150 PSI (10 Bar)  
**End Connections:** ANSI 150# carbon steel flanges.  
**Flow tube Material:** AISI 316 stainless steel.  
**Housing and flange material:** Carbon steel, enamel paint finishing.  
**Liner Material:** PTFE.  
**Electrode material:** Alloy C.  
**Maximum Liquid Temperature:** 212°F (100°C).

**Amplifier:**

**Power Supply:** 110 VAC ±10%, 5 VA.  
**Coil excitation:** Pulsed DC, 7.5 Hz.  
**Minimum liquid conductivity:** 5 micromhos/cm.  
**Maximum output frequency:** 10 khz.  
**System accuracy:** ±0.5% of rate.  
**Repeatability:** ±0.2%  
**Enclosure:** Powder coated cast aluminum, NEMA 4.  
**Mounting:** Meter mounted only.  
**Environmental:** -4°F to 122°F (-20° to 50°C).  
**Output 1:** Solid state relay up to 230V, 500 mA.  
**Output 2:** Opto-isolated open collector, 50 mA @ 24VDC.  
**Pulse Width:** 50% duty cycle.  
**Cable Connections:** (2) 1/2" NPT. cord grip.



Please see our website at  
[www.badgermeter.com](http://www.badgermeter.com)  
 for specific contacts.



**BadgerMeter, Inc.**

P.O. Box 245036, Milwaukee, WI 53224-9536  
 Telephone: (414) 355-0400 / (877) 243-1010  
 Fax: (414) 355-7499 / (866) 613-9305

6116 East 15th Street, Tulsa, OK 74112  
 Telephone: (800) 364-9876 / Fax: (918) 832-9962  
[www.badgermeter.com](http://www.badgermeter.com)

Due to continuous research, product improvements and enhancements, Badger Meter reserves the right to change product or system specifications without notice, except to the extent an outstanding bid obligation exists.